

Professional

Engineering

Services

Americans with Disabilities Act Transition Plan

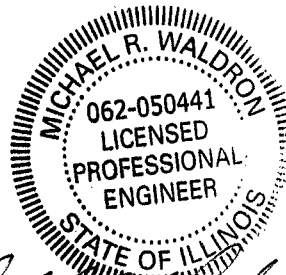
Report

Village of
Orland Park, IL
January 1, 2021



Report for
Village of Orland Park, Illinois

Americans with Disabilities Act Transition Plan



Michael R. Waldron 10/30/20
EXP 11/30/21

Prepared by:

STRAND ASSOCIATES, INC.®
IDFPR No. 184-001273
1170 South Houbolt Road
Joliet, IL 60431
www.strand.com
January 2021



TABLE OF CONTENTS

Page No.
or Following

EXECUTIVE SUMMARY

SECTION 1–REQUIRED INFORMATION

1.01	General Transition ADA Plan Requirements.....	1-1
1.02	Responsible Official.....	1-1
1.03	Grievance Procedure	1-1
1.04	Self-Evaluation and Prioritization of Physical Barriers	1-2
1.05	Undue Burden and Funding Availability	1-2
1.06	Public Notice	1-3
1.07	Abbreviations and Definitions	1-3

SECTION 2–PROGRAMS AND SERVICES EVALUATION

2.01	Programs and Services Evaluation Overview	2-1
2.02	ADA and Section 504	2-1
2.03	General Effective Communication	2-1
2.04	9-1-1 and Emergency Communications Services	2-2
2.05	Website Accessibility	2-2
2.06	Emergency Management	2-3
2.07	Pace Dial-a-Ride	2-7
2.08	Recreation and Parks Operations.....	2-7

SECTION 3–PUBLIC FACILITIES EVALUATION

3.01	Public Facilities Evaluation Overview	3-1
3.02	Public Buildings and Facilities Evaluation	3-1

SECTION 4–PUBLIC RIGHTS-OF-WAY EVALUATION

4.01	Public Rights-of-Way Evaluation Overview.....	4-1
4.02	Sidewalk Evaluation	4-1
4.03	Curb Ramps and Pedestrian Crossing Evaluations	4-2
4.04	Self-Evaluation Efforts.....	4-3

SECTION 5–TRANSITION PLAN COST ANALYSIS

5.01	Overview	5-1
------	----------------	-----

TABLE OF CONTENTS Continued

Page No.
or Following

TABLES

3.02-1	List of Facilities Owned by the Village	3-1
3.02-2	List of Recreational Facilities Owned by the Village.....	3-2
3.02-3	Self-Evaluation Opinion of Effort–Public Facilities	3-4
4.04-1	Self-Evaluation Opinion of Effort–Public Right-of-Way	4-3
5.01-1	ADA Transition Plan Self-Evaluation Cost Estimate	5-1

APPENDICES

APPENDIX A–GRIEVANCE PROCEDURE
APPENDIX B–ADA AND SECTION 504 CHECKLIST
APPENDIX C–GENERAL EFFECTIVE COMMUNICATION CHECKLIST
APPENDIX D–9-1-1 AND EMERGENCY COMMUNICATIONS SERVICES CHECKLIST
APPENDIX E–WEBSITE ACCESSIBILITY CHECKLIST
APPENDIX F–EMERGENCY MANAGEMENT CHECKLISTS
APPENDIX G–BUILDING AND FACILITY CHECKLISTS
APPENDIX H–CURB RAMPS AND PEDESTRIAN CROSSINGS CHECKLISTS
APPENDIX I–ADA TRANSITION PLAN FOR RECREATION AND PARKS
APPENDIX J–BUS STOP ACCESSIBILITY AND SAFETY TOOLKIT/COMPLIANCE PLAN
APPENDIX K–ORLAND PARK PLAYGROUND ASSESSMENT

Title II of the Americans with Disabilities Act (ADA) prohibits general discrimination by local governments on the basis of disability contained in Section 504 of the Rehabilitation Act of 1973. It prohibits the Village of Orland Park, Illinois (Village), from denying persons with disabilities the equal opportunity to participate in its services, programs, or activities, either directly or indirectly through contractual agreements.

This ADA Transition Plan is a commitment by the Village to provide equal access to its public programs, services, facilities, and activities for citizens with disabilities.

It is important that the Village, as a recipient of federal funding, complies with all applicable federal and state laws, including those protecting persons with disabilities under Section 504.

The Village designated Terica Ketchum, Assistant to the Village Manager/Risk Manager, as ADA Coordinator, the person responsible for the development and implementation of the ADA Transition Plan. The Village Manager and Village Board are also responsible for the operations and procedures of the Village.

The Village has implemented a formal grievance procedure to allow for complaints to be filed with the ADA Coordinator. This procedure and associated forms have been posted on the Village's website.

The Village has been and will continue to perform a series of self-evaluations to identify physical barriers that currently exist. It will then create a priority list and schedule for removing the identified barriers. Section 2 provides the results of the Village's self-evaluation with regard to its programs, services, activities, and facilities. From this self-evaluation, the Village identified deficiencies and intends to address these deficiencies over the next five years.

Sections 3 and 4 provide guidance for the Village to perform self-evaluations with regard to public buildings owned by the Village and public right-of-way including sidewalks and curb ramps. The effort to perform these self-evaluations is significant. The Village will perform these self-evaluations and address identified deficiencies as part of any building improvement projects and roadway construction projects. The Village will also endeavor to perform self-evaluations of public buildings and rights-of-way over the next five to nine years. Section 5 of this report provides an opinion of probable cost to complete the self-evaluation effort outlined in Sections 3 and 4.

Results from the self-evaluations will be appended to this ADA Transition Plan on an annual basis and will be used to develop an ADA improvement program to address identified deficiencies. The ADA improvement program shall also be appended to this Transition Plan.

According to the ADA, the Village does not have to take action on ADA improvements if it can demonstrate that it would result in fundamental alteration of the nature of a program or activity, would create a hazardous condition for other people, or would represent an undue financial and administrative burden. This determination can only be made by the ADA Coordinator, department head, or designee, and must be accompanied by a statement citing the reasons for reaching that conclusion.

The Village will update the plan following the public meeting once a year to reflect completed improvement projects or additions or changes suggested by the public, as appropriate.

**SECTION 1
REQUIRED INFORMATION**

The purpose of this section is to lay out the minimum requirements for the Village of Orland Park, Illinois (Village), to achieve compliance with Title II of the Americans with Disabilities Act (ADA) in its programs, services, activities, and facilities.

1.01 GENERAL ADA TRANSITION PLAN REQUIREMENTS

Title II requires that all public entities receiving federal funds perform a self-evaluation of all public programs, services, facilities, and the public right-of-way to identify barriers that limit accessibility to individuals with disabilities; prepare a transition plan to address the identified barriers; make the self-evaluation data available for three years; and publish a notice of nondiscrimination.

ADA regulations require that the ADA Transition Plan contains the following elements.

1. The name of the Village official responsible for implementation of the ADA Transition Plan.
2. A formal grievance procedure that sets out a system for resolving complaints of disability discrimination in a prompt and fair manner.
3. A list of physical barriers in the Village’s facilities that limit accessibility of its programs, services, or activities to individuals with disabilities.
4. A detailed description of the methods to be used to remove these barriers and make the facilities accessible.
5. A schedule for taking the necessary steps to achieve compliance with Title II.
6. A schedule for providing curb ramps or other sloped areas where pedestrian walkways cross the curb and gutter.

1.02 RESPONSIBLE OFFICIAL

An ADA Coordinator has been designated by the Village of Orland Park as the person responsible for the development and implementation of the ADA Transition Plan.

At the time of this ADA Transition Plan, Terica Ketchum, Assistant to the Village Manager/ Risk Manager, has been designated as the ADA Coordinator.

The Village Manager and Village Board are also responsible for the operations and procedures of the Village.

1.03 GRIEVANCE PROCEDURE

A formal grievance procedure has been established to allow for complaints to be filed with the ADA Coordinator. This procedure is located in Appendix A.

1.04 SELF-EVALUATION AND PRIORITIZATION OF PHYSICAL BARRIERS

The purpose of the self-evaluation process is to identify physical barriers that currently exist and then create a priority list and schedule for removing the barriers. Sections 2, 3, and 4 of this report provide details of the self-evaluation program, identify currently known barriers, and provide priority lists and schedules for removing the barriers. Section 2 deals with Village’s programs, services, and activities. Section 3 deals with public buildings and facilities. Section 4 deals with public rights-of-way including sidewalks and curb ramps.

Section 5 of this report provides an opinion of probable cost to complete the self-evaluation effort outlined in Sections 3 and 4. An opinion of probable construction cost and priority list to implement the improvements will be generated after the self-evaluation effort is complete.

1.05 UNDUE BURDEN AND FUNDING AVAILABILITY

According to the ADA, the Village does not have to take action if it can demonstrate that it would result in fundamental alteration of the nature of a program or activity, would create a hazardous condition for other people, or would represent an undue financial and administrative burden. This determination can only be made by the ADA coordinator, department head, or designee, and must be accompanied by a statement citing the reasons for reaching that conclusion.

The determination that an undue financial burden would result must be based on an evaluation of all resources available for use in a program. For example, if a barrier removal action is judged unduly burdensome, the Village must consider other options for providing access that would ensure that individuals with disabilities receive the benefits and services of the program or activity.

Upon funding availability, the Village will implement a barrier removal program within the right-of-way and facilities. Accessibility improvements that can be made through general maintenance of Village facilities (signage, clear pathways, and relocation of restroom fixtures) or as part of the regular administrative duties of staff (providing documents in alternate forms and training) will typically be completed first, with larger capital improvements projects being completed when necessary funding is available.

Standards implemented by the Village, when undergoing new or improvement road projects, will adhere to ADA regulations and published Illinois Department of Transportation (IDOT) Standard Drawings for pedestrian access details for curb ramps, median curb details, pedestrian islands, driveways and driveway aprons, stairway and handrail requirements, and accessible parking; all aided by a detectable warning surface where applicable.

1.06 PUBLIC NOTICE

This initial plan will be made available at Village Hall and at any public meetings held regarding the plan.

Upon completion of the initial plan, the Village will provide a meeting for the public to express concerns and comments regarding the ADA Transition Plan. The meeting will be advertised in a newspaper with local circulation.

The Village will update the plan following the public meeting and once a year to reflect completed improvement projects or additions or changes suggested by the public, as appropriate.

1.07 ABBREVIATIONS AND DEFINITIONS

28 CFR 35	Title 28 of the Code of Federal Regulations Part 35
ADA	Americans with Disabilities Act
Department	Recreation and Parks Department
EEO	Equal Employment Opportunity
IDOT	Illinois Department of Transportation
LPA	Local Public Agency
MUTCD	Manual on Uniform Traffic Control Devices
Section 504	Section 504 of the Rehabilitation Act of 1973
Village	Village of Orland Park, Illinois

SECTION 2
PROGRAMS AND SERVICES EVALUATION

2.01 PROGRAMS AND SERVICES EVALUATION OVERVIEW

The Village seeks to improve accessibility for the public throughout its programs and services. This is being accomplished primarily by appointing an ADA Coordinator who will oversee the procedural changes to be made to the Village’s existing programs and services to meet the current regulations according to Title II of the ADA, Section 504 of the Rehabilitation Act of 1973 (Section 504), and all related laws.

In accordance with this ADA Transition Plan, the Village initiated a self-evaluation of its programs and services to determine those that are noncompliant. Additionally, the Village retained Recreation Accessibility Consultants, LLC for evaluation of the Village’s recreation programs and facilities.

This section outlines the results of this self-evaluation and recommended solutions to achieve compliance with the current regulations.

2.02 ADA AND SECTION 504

The Village performed a self-evaluation of the requirements and tasks of the ADA Coordinator, the Village’s provision of the ADA notice, and the Village’s ADA grievance procedures. The checklist used to perform self-evaluations can be found in Appendix B.

No deficiencies were found.

2.03 GENERAL EFFECTIVE COMMUNICATION

The Village performed a self-evaluation of compliance with the regulations of ADA with regard to the Village’s general effective communication. The checklist used to perform this self-evaluation can be found in Appendix C.

Following are items that, after self-evaluation, were found to be noncompliant.

1. Not all employees who interact with the public have been trained on the correct procedures to follow when a person asks for an interpreter.
2. The Village does not have the equipment or arrangements with vendors to provide written materials in alternative formats (e.g., braille, large print, audio format, and electronic format).
3. Not all of the videos and television programs the Village produces and not all the videos it makes available to the public on its website are available with captioning and audio description.

The Village will address noncompliant items in the years 2020 to 2025.

2.04 9-1-1 AND EMERGENCY COMMUNICATIONS SERVICES

The Village performed a self-evaluation of compliance with the regulations of ADA with regard to the Village’s 9-1-1 and emergency communication services. The checklist used to perform this self-evaluation can be found in Appendix D.

Following are items that, after self-evaluation, were found to be noncompliant.

1. The Village does not regularly schedule tests of the TTY telephone emergency services.

The Village will address noncompliant items in the years 2020 to 2025.

2.05 WEBSITE ACCESSIBILITY

The Village performed a self-evaluation of compliance with the regulations of ADA with regard to the Village’s web site services provided at <https://www.orlandpark.org>. The checklist used to perform this self-evaluation can be found in Appendix E.

Following are items that, after self-evaluation, were found to be noncompliant.

1. Establish a policy that webpages will be accessible and create a process for implementation.
2. Check the HTML of all new webpages. Make sure that accessible elements are used, including “alt” tags, long descriptions, and captions, as needed.
3. Ensure that webpages are designed in a manner that allows them to be displayed using a visitor’s own settings for color and fonts.
4. Make sure to include text equivalents for them using “alt” tags and/or long descriptions if images are used, including photos, graphics, scanned images, or image maps. Ensure that the text equivalents convey the meaningful information presented visually by the image.
5. Make elements accessible if using online forms and tables.
6. Ensure that videos appearing on the website include appropriately synchronized audio descriptions and captions.
7. Always provide documents in HTML or another text-based format (even if you are also providing them in another format, such as PDF) when posting new documents on the website. If documents are provided in both formats, provide both formats at the same time so people with disabilities have the same degree of access as others.
8. Develop a plan for making the existing web content accessible, including specific steps and timeframes. Describe the plan on an accessible webpage that can be easily located from your home page. Encourage input on accessibility improvements, including which pages should be given high priority for change. Let citizens know about the standards or

guidelines that are being used to provide accessibility. Make accessibility modifications to the more popular webpages on the website a priority.

9. Ensure that in-house staff and contractors responsible for webpages and webpage content development are properly trained on the Village’s accessibility policy and procedures.
10. Provide a way for visitors to request accessible information or services and provide feedback about accessibility problems by posting a telephone number and email address on your home page. Establish procedures to assure a quick response to people with disabilities who use this contact information to access web-based information or services.
11. Enlist those with a variety of disabilities to periodically test your webpages for accessibility and ease of use. Use this information to increase your website accessibility.
12. Consider using one of the no-cost or low-cost resources available on the Internet to test the accessibility of the website. (Please note, however, that these products may not identify all accessibility problems on the website.)
13. Ensure that alternative means are available for people with disabilities who are unable to use computers to access information, programs, and services that are normally provided on your website.

The Village will address noncompliant items in the years 2020 to 2025.

2.06 EMERGENCY MANAGEMENT

The Village performed a self-evaluation of compliance with the regulations of ADA with regard to the Village’s emergency management programs. Checklists used for this self-evaluation can be found in Appendix F, which includes Addendum 1, a checklist for general emergency management, and Addenda 2 and 3 that provide information on emergency shelters.

A. Emergency Notification and Evacuation

Following are items that, after self-evaluation, were found to be noncompliant with regard to general emergency management policies and procedures and planning for emergency notification and evacuation.

1. Seek and use input from people with different types of disabilities (i.e., mobility, vision, hearing, cognitive, psychiatric, and other disabilities) and organizations with expertise on disability issues regarding all phases of the emergency management plan, including staging emergency simulations and testing preparedness on an ongoing basis. For example, enlist people with disabilities to role-play during simulation exercises and provide feedback.

2. Adopt policies to ensure that community evacuation plans enable people with disabilities, including those who have mobility, vision, hearing, cognitive, and psychiatric disabilities, to safely self-evacuate or be evacuated by others.
3. Create voluntary, confidential registries of persons with disabilities who may need individualized notification, evacuation assistance, and/or transportation. Procedures should ensure that the registries are confidential, guarantee confidentiality to those who register, and include a process to periodically update the information contained in the registry.
4. Identify accessible modes of transportation, such as wheelchair lift-equipped school buses, transit buses, paratransit vans, and taxi cabs that will be available to help evacuate people with disabilities during an emergency. Ensure that the plan addresses the needs of people with disabilities, including those who use wheelchairs, scooters, medical equipment, and service animals, as well as those who will need assistance getting from their homes to emergency transportation pickup locations or staging areas.
5. Develop instructions for staff and volunteers who will perform duties related to emergency notification, evacuation, transportation, and the routing of people with disabilities and their families to, and placement of these individuals in, shelters.
6. Develop site-specific instructions and training materials for “mass care,” “medical,” and “special needs” shelter volunteers and staff to ensure compliance with ADA requirements to provide access to programs, services, and activities offered at the shelter and to address any concerns raised by people with disabilities. Include in the instructions and training materials, the information in this chapter, including Addenda 2 and 3, on shelter accessibility, eligibility criteria, effective communication, reasonable modifications in policies, practices, procedures for service animals, and other reasonable modifications.
7. Train individuals involved in the emergency management process to recognize issues that may affect people with a variety of disabilities and on the procedures to follow when access issues for individuals with disabilities arise during the course of an emergency or disaster, such as contacting the Village’s ADA Incident Manager for guidance.

Physical accessibility in emergency shelters is addressed in a separate ADA Transition Plan developed for the Recreation and Parks Department, whose facilities are used as emergency shelters. A copy of the plan is attached in Appendix I.

B. Emergency Shelters

Following are items that, after self-evaluation, were found to be noncompliant with regard to policies and procedures in emergency shelters.

1. Adopt procedures to provide effective communication for people who are deaf or hearing impaired, people with severe speech disabilities, and people who are blind or have low vision. Train staff on the basic procedures for providing effective communication, including exchanging notes or posting written announcements to go with spoken announcements. Provide a TTY in each shelter for persons who are deaf, are hard of hearing, or have speech disabilities. Provide interpreters when necessary to ensure

- effective communication. Train staff and volunteers to read printed information, upon request, to persons who are blind or who have low vision.
2. Offer low-stimulation “stress-relief zones” if space permits. Adopt policies and procedures to make these areas available on a priority basis to people whose disabilities are aggravated by stress.
 3. Adopt eligibility policies and procedures that ensure that people with disabilities are housed in “mass care” shelters unless they are medically fragile. The procedures should ensure that shelter staff and volunteers accept people with disabilities who need some assistance with activities of daily living, even though their personal care aides may not be with them. Also, provide training and monitoring for staff and volunteers on safe and appropriate procedures for providing assistance in daily living activities to people with disabilities who require such assistance.
 4. Adopt eligibility policies and procedures to ensure that emergency managers do not require people with disabilities to stay in these shelters solely because they have a disability if you provide a “special needs” or “medical” shelter. Special needs and medical shelters are intended to house people who are medically fragile, such as those who require hospital or nursing home care. The ADA requires emergency managers and shelter operators to accommodate people with disabilities in the most integrated setting appropriate to their needs.
 5. Modify “no pets” policies to allow people with disabilities to stay in shelters—and participate in shelter programs, services, and activities—with their service animals. Also, provide food, water, and waste disposal supplies for service animals.
 6. Ensure that a reasonable number of shelters have backup generators and a way to keep medications refrigerated (such as a refrigerator or a cooler with ice). Make these shelters available on a priority basis to people whose disabilities require access to electricity and refrigeration. Until all shelters have backup generators and refrigeration capacity, routinely notify the public about the location of the shelters that have these features.
 7. Establish policies and procedures ensuring that people who need electricity for life-sustaining equipment have priority access to it when it is available and that priority access is also provided, where feasible, for people with disabilities who rely on electrically powered mobility devices.
 8. Establish policies and procedures and make advance arrangements for resources to ensure that there is an effective way for people with disabilities to request and receive durable medical equipment and medication.
 9. Establish policies and procedures and make advance resource arrangements so that people with disabilities can request cots and beds, modifications to cots and beds, securing cots and beds, and specific placement of cots, beds, or sleeping mats when needed. In shelters where people will generally be expected to use sleeping mats placed on the floor, ensure that some cots and beds are available for people with disabilities who are unable to use sleeping mats. The procedures on cots and beds should provide for staff and volunteers to consult with people with disabilities about their needs and provide necessary accommodations.

10. Modify kitchen access policies so that residents and volunteers whose disabilities may require it can obtain immediate access to food and refrigerated medication. Also, in planning food supplies for shelters, ensure that at least some kinds of foods and beverages are available for people with dietary restrictions, such as diabetes or severe food allergies.

C. Medical and Social Services

Following are items that, after self-evaluation, were found to be noncompliant with regard to medical and social services.

1. Establish policies and procedures to ensure that medical, social service, and other benefit programs are accessible to people with disabilities including people who use wheelchairs, scooters, and other mobility aids, and people who use service animals.
2. Establish policies and procedures to ensure that medical, social service, and other benefit programs do not have eligibility criteria that screen out or tend to screen out people with disabilities, or application processes or procedures that deny access to people with disabilities.
3. Establish policies and procedures to ensure that medical, social service, and other benefit programs provide effective communication to people with disabilities including primary consideration of the method of communication preferred by an individual with a disability.

D. Post-Sheltering Policies and Procedures

Following are items that, after self-evaluation, were found to be noncompliant with regard to post-sheltering policies and procedures.

1. Modify policies as necessary to provide transportation, search assistance, and additional time in shelters to individuals with disabilities who are attempting to locate housing.
2. Identify temporary accessible housing (such as accessible hotel rooms within the community or in nearby communities) that could be used if people with disabilities cannot immediately return home after a disaster. Consider establishing temporary housing procedures to ensure that accessible hotel rooms are available on a priority basis to people with disabilities who need them.
3. Establish policies and procedures to ensure that temporary housing information distributed to the public or to shelter residents includes information on accessible housing and transportation resources.

E. Post-Emergency Repair, Rebuilding, and Resumption of Programs

Following are items that, after self-evaluation, were found to be noncompliant with regard to post-emergency repair, rebuilding, and resumption of program operations.

1. Establish policies and procedures to ensure that facilities constructed or altered because of emergency- or disaster-related damage comply with the accessibility requirements of

Title II of the ADA. Facilities constructed after January 26, 1992, and repairs to such facilities, must comply with Title II’s new construction requirements. Alterations to facilities constructed before the ADA became effective must comply with Title II’s requirements for alterations to existing facilities. Alterations may not decrease accessibility.

2. Establish policies and procedures to ensure that programs relocated from a damaged facility remain accessible to people with disabilities, whether the relocation is permanent or temporary. Ensure that continuity of operations plans addresses continuity of access to programs, services, and activities for people with disabilities. Ensure that repair and cleanup activities include the maintenance of accessible features.

The Village will address noncompliant items in the years 2020 to 2025.

2.07 PACE DIAL-A-RIDE

The Village’s Transportation Division of the Public Works Department operates the Pace Dial-a-Ride Paratransit Bus Service. Service is funded by passenger fares, a Pace grant through the Regional Transportation Authority, and from general fund subsidies.

The Village is seeking to improve accessibility to these facilities and the services they provide by completing a self-evaluation to determine what barriers exist and incorporating a plan to remove the barriers. Appendix J contains a Bus Stop Accessibility and Safety Toolkit that the Village will use to evaluate Pace Dial-A-Ride facilities and programs for compliance with the regulations of ADA.

An inventory of any non-compliance issues will be appended to Appendix J of the ADA Transition Plan and serve as an important tool to assist in programming, scoping, development, and implementation.

The Village will address noncompliant items in the years 2020 to 2025.

2.08 RECREATION AND PARKS OPERATIONS

In 2019, the Recreation and Parks Department (Department) and Village undertook a complete parks assessment. As part of this assessment, ADA accessibility at playgrounds was assessed for security, accessibility, and general conditions. The complete 2019 Parks Assessment is included as Appendix K. As a result of that study, in 2020 accessibility issues were addressed at the following Parks: Bill Young, Cameno Real, Discovery, Pulte, Spring Creek, Village Square, Wedgewood Estates, Ishnala, and Ishnala Woods. For future assessments, the Department and Village will use a handbook titled “ADA Transition Plan for Recreation and Parks” that is consistent with state and federal ADA requirements and the mission of the Department and Village.

The handbook will be used by department staff in ways including, but not limited to, the following:

1. A Department employee can use it to identify an effective process for supporting a person with a disability.

2. To enable participation in an activity by a registrant with an injury, illness, or disability.
3. Department customers with a disability can use it as a guide to help define an expectation of the support that should be available to enable participation.

A copy of the handbook can be found in Appendix I.

3.01 PUBLIC FACILITIES EVALUATION OVERVIEW

The Village owns and maintains 18 buildings and facilities that are used for public programs or have some level of public use. The Village is seeking to improve accessibility to these facilities and the services they provide by completing a self-evaluation to determine what physical barriers currently exist and incorporating a plan to remove those barriers. The Village will also require any renovation or new construction projects that are performed for facilities that have public programs or services to meet current ADA regulations.

An inventory of the Village’s facilities will be updated as evaluations are completed and will be included in Appendix G of the ADA Transition Plan to serve as an important tool to assist in project programming, scoping, development, and implementation.

3.02 PUBLIC BUILDINGS AND FACILITIES EVALUATION

A. Public Buildings

Facilities such as the Police Department and Public Works have limited public access. In all facilities, only those areas accessible by the public would be evaluated. Other employee-occupied areas are covered under equal employment opportunity regulations and not the ADA regulations. Facilities like water booster stations or sanitary pumping stations would not be evaluated unless these facilities have potential for public access, such as tours or open houses.

Facility Name	Address	Provides Public Programs?	Facility Contact
Frederick T. Owens Village Hall	14700 S. Ravinia Avenue	Yes	ADA Coordinator
Orland Park Civic Center	14750 Ravinia Avenue	Yes	ADA Coordinator
Orland Park Historical Museum and Old Village Hall	14413 Beacon Avenue	Yes	ADA Coordinator
George Brown Commons	15045 West Avenue	Yes	ADA Coordinator
Orland Park Police Department	15100 S. Ravinia Avenue	Yes	ADA Coordinator
Orland Park Public Works Department	15655 S. Ravinia Avenue	Yes	ADA Coordinator
Water and Wastewater Facilities	Throughout Village	No	ADA Coordinator
Orland Park Train Stations at 143rd, 159th, and 179th Streets	143rd, 159th, and 179th Streets	Yes	ADA Coordinator

Table 3.02-1 List of Facilities Owned by the Village

B. Recreational Public Facilities

Facility Name	Address	Provides Public Programs?	Facility Contact
Orland Park Recreation Administration	14600 S. Ravinia Avenue	Yes	ADA Coordinator
Franklin E. Loebe Recreation Center	14650 S. Ravinia Avenue	Yes	ADA Coordinator
Orland Park Sportsplex	11351 West 159th Street	Yes	ADA Coordinator
Robert Davidson Center	14700 S. Park Lane	Yes	ADA Coordinator
Orland Park Cultural Arts Center	14760 S. Park Lane	Yes	ADA Coordinator
John Humphrey Parks Department	147th and West Avenue	No	ADA Coordinator
John Humphrey Park Concessions	147th and West Avenue	No	ADA Coordinator
Centennial Park Aquatic Center	15600 West Avenue	Yes	ADA Coordinator
Centennial Park Ice Rink	15600 West Ave to Fun Drive	Yes	ADA Coordinator
Centennial Park Concessions	15600 West Ave to Fun Drive	No	ADA Coordinator
Nature Center	13951 LaGrange Road	Yes	ADA Coordinator
Stellwagen Farm	108th Avenue & Louetta Lane	Yes	ADA Coordinator
Boley Farm	151st Street and 81st Court	Yes	ADA Coordinator
Hostert Log Cabins	West Avenue and 147th Street	Yes	ADA Coordinator
Multiple Parks, Fields, and Playgrounds	Throughout Village	Yes	ADA Coordinator

Table 3.02-2 List of Recreational Facilities Owned by the Village

C. Planning for Identified Improvements

Upon completion of self-evaluations, funding for building and facility accessibility improvements will be prioritized with preference to the following locations.

1. Where deficiencies are identified through the grievance procedure.

2. Where facility or building renovations or additions are taking place.
3. Locations specifically requested by the public.
4. Locations that most often provide public programs and services.
5. All other locations containing barriers.

The prioritization for improvements at a particular facility will be in the following order.

1. Removing physical access barriers in areas where renovations or additions are being constructed.
2. Removing physical access barriers in parking areas.
3. Removing physical access barriers on the route to the accessible entrance to the facility.
4. Removing physical access barriers on interior routes to the public programs and services provided at the facility.
5. Removing physical access barriers at the location of public programs and services within the facility.

Additionally, any new construction or renovations for facilities that provide public programs and services will be completed in accordance with current ADA regulations.

D. Self-Evaluation Efforts

The Village began a self-evaluation process of its parks in 2019 and performed improvements on select parks as discussed in Section 2. The Village intends to continue to perform self-evaluation of the following Village-owned facilities over the five-year period from 2020 to 2024, based on evaluating approximately four major buildings a year. Checklists used to perform the building and facility evaluations can be found in Appendix G. Upon completion of this self-evaluation, the results and a plan to address identified barriers will also be included in Appendix G.

Table 3.02-3 provides an opinion of probable hours and costs for performing self-evaluations of the Village buildings and facilities.

Building or Facility	Total Hours	Cost per hour	Total Cost
Frederick T. Owens Village Hall	44	\$140	\$6,160
Orland Park Civic Center	52	\$140	\$7,280
Orland Park Historical Museum/Old Village Hall	24	\$140	\$3,360
George Brown Commons	24	\$140	\$3,360
Orland Park Police Department	44	\$140	\$6,160
Orland Park Public Works Department	32	\$140	\$4,480
Water and Wastewater Facilities (13 at 8 hours each)	104	\$140	\$14,560
Orland Park Train Stations (3 at 24 hours each)	72	\$140	\$10,080
Recreation Administration Building	32	\$140	\$4,480
Franklin E. Loebe Recreation Center	62	\$140	\$8,680
Orland Park Sportsplex	84	\$140	\$11,760
Robert Davidson Center	32	\$140	\$4,480
Orland Park Cultural Arts Center	44	\$140	\$6,160
Nature Center	24	\$140	3,360
Stellwagen Farm	8	\$140	\$1,120
Boley Farm	8	\$140	\$1,120
Hostert Log Cabins	8	\$140	\$1,120
Centennial Park Aquatic Center	32	\$140	\$4,480
Centennial Park Ice Rink	32	\$140	\$4,480
Centennial Park Concessions	24	\$140	\$3,360
Totals	786		\$110,040

Table 3.02-3 Self-Evaluation Opinion of Effort–Public Facilities

SECTION 4
PUBLIC RIGHTS-OF-WAY EVALUATION

4.01 PUBLIC RIGHTS-OF-WAY EVALUATION OVERVIEW

The Village owns and maintains over 280 miles of public rights-of-way and approximately 1,880 intersections (excluding Illinois Department of Transportation- (IDOT), county-, and township-owned mileage and intersections). The Village is seeking to improve accessibility within Village right-of-way by completing a self-evaluation of curb ramps and sidewalks to determine what physical barriers currently exist and then incorporating a plan to remove them. The Village will also require any renovation or new construction projects that encompass or are adjacent to curb ramps and sidewalks to meet current ADA regulations.

The Village continually evaluates ADA compliance as part of its annual road program. Evaluations are also performed as part of the Village's complaint process. On average, the Village replaces approximately 0.28 mile of sidewalk each year as part of the complaint process and 1.77 miles of sidewalk each year as part of the road program.

The Village will continue to address noncompliant items identified through the complaint or grievance process and in conjunction with its annual roadway improvement programming. Additionally, the village will address deficiencies identified through the ongoing self-evaluation process using an annual discretionary budget.

An inventory of the Village's facilities in the public right-of-way will be updated as evaluations are completed and will be included in Appendix H of the Transition Plan to serve as an important tool to assist in project programming, scoping, development, and implementation.

4.02 SIDEWALK EVALUATION

The Village owns approximately 450 miles of sidewalk. The Village intends to perform self-evaluations during the nine-year period from 2020 to 2029 for compliance with the regulations of ADA with regard to sidewalks.

Funding for sidewalk reconstruction projects will be prioritized with preference given to the following locations.

1. Locations where deficiencies are identified through the grievance procedure.
2. Locations where street improvements or curb ramp construction are taking place.
3. Locations requested by the public.
4. Locations adjacent to and requiring frequent accessibility to public programs and services.
5. All other existing sidewalk locations.

All sidewalk reconstruction and new construction will be done in accordance with the current ADA regulations.

4.03 CURB RAMPS AND PEDESTRIAN CROSSING EVALUATIONS

The Village owns approximately 6,600 curb ramps within the public right-of-way. The Village intends to perform self-evaluations in the nine-year period from 2020 to 2029 for compliance with ADA regulations with regard to curb ramps and pedestrian crosswalks. The checklist for this self-evaluation can be found in Appendix H.

Funding for curb ramp construction and reconstruction projects will be prioritized beginning with replacement and giving preference to the following locations:

1. Locations where deficiencies are identified through the grievance procedure.
2. Locations where street or sidewalk improvements are taking place.
3. Locations requested by the public.
4. Locations adjacent to and frequently requiring accessibility to public programs and services.

If additional funding is available or curb ramp replacement efforts have been completed, new curb ramp construction will be prioritized in the following order (at intersections where both ramp replacement and new construction are needed, construction of all ramps should be done concurrently).

1. Locations where street or sidewalk improvements are taking place.
2. Locations requested by the public.
3. Locations adjacent to and increasing accessibility to public programs and services.
4. Other locations that are part of the existing sidewalk network.
5. All other intersection within the public right-of-way.

All replacement and construction of new curb ramps will be completed according to current ADA regulations.

4.04 SELF-EVALUATION EFFORTS

Table 4.04-1 provides an opinion of probable hours and costs for performing self-evaluations of the Village rights-of-way for sidewalks, curb ramps, and pedestrian crossings.

Right-of-Way Assessments	Total Hours	Cost per Hour	Total Cost
Sidewalk assessments	1,225	\$136	\$166,600
Intersection assessments	1,287	\$136	\$175,032
Total	2,512		\$341,632

Table 4.04-1 Self-Evaluation Opinion of Effort–Public Right-of-Way

SECTION 5
TRANSITION PLAN COST ANALYSIS

5.01 OVERVIEW

The costs presented in this section are for completion of the self-assessment effort only and do not include construction cost of improvements that may be required. An opinion of probable construction cost will be created after the self-evaluations are complete and the scope of necessary improvements is known. At that time, an improvement priority list will be created according to the criteria listed in Sections 3 and 4. Priorities are likely to shift based on funding availability, scheduled maintenance, planned improvements, or location of services. In conjunction with the ADA Coordinator, it is recommended that the Village implement the following projects in the order that makes best use of its resources given the knowledge of planned programs and availability of funding at that time.

Table 5.01-1 provides an opinion of probable cost to complete the self-evaluations of public facilities and public rights-of-way as outlined in Sections 3 and 4 of this ADA Transition Plan.

Building or Facility Assessments (Section 3)	Cost
Frederick T. Owens Village Hall	\$6,160
Orland Park Civic Center	\$7,280
Orland Park Historical Museum/Old Village Hall	\$3,360
George Brown Commons	\$3,360
Orland Park Police Department	\$6,160
Orland Park Public Works Department	\$4,480
Water/Wastewater Facilities (13 at 8 hours each)	\$14,560
Orland Park Train Stations (3 at 24 hours each)	\$10,080
Recreation Administration Building	\$4,480
Franklin E. Loebe Recreation Center	\$8,680
Orland Park Sportsplex	\$11,760
Robert Davidson Center	\$4,480
Orland Park Cultural Arts Center	\$6,160
Nature Center	\$3,360
Stellwagen Farm	\$1,120
Boley Farm	\$1,120
Hostert Log Cabins	\$1,120
Centennial Park Aquatic Center	\$4,480
Centennial Park Ice Rink	\$4,480
Centennial Park Concessions	\$3,360
Subtotal	\$110,040
Right-of-Way Assessments (Section 4)	
Sidewalk assessments	\$166,600
Intersection assessments	\$175,032
Subtotal	\$341,632
Total Cost to Complete Self-Evaluations	\$451,672

Table 5.01-1 ADA Transition Plan Self-Evaluation Cost Estimate

A.01 GRIEVANCE PROCEDURE

A. Village of Orland Park Grievance Procedure Under the Americans with Disabilities Act

This Grievance Procedure is established to meet the requirements of the Americans with Disabilities Act of 1990 (ADA). It may be used by anyone who wishes to file a complaint alleging discrimination on the basis of disability in the provision of services, activities, programs, or benefits by the Village of Orland Park, Illinois (Village). The Village's Personnel Policy governs employment-related complaints of disability discrimination.

The complaint should be in writing and contain information about the alleged discrimination such as name, address, and phone number of complainant, and location, date, and description of the problem. Alternative means of filing complaints, such as personal interviews or a tape recording of the complaint, will be made available for persons with disabilities upon request.

The complaint should be submitted by the grievant and/or his/her designee as soon as possible but no later than 30 calendar days after the alleged violation. The complaint must be submitted by hand, mailed, or via e-mail to:

Ahmad Zayyad, Assistant to the Village Manager /Risk Manager
14700 South Ravinia Avenue
Orland Park, IL 60462
Phone: (708) 403-6245
Email: azayyad@orlandpark.org

Within 15 calendar days after receipt of the complaint, the ADA Coordinator or his/her designee will meet with the complainant to discuss the complaint and the possible resolutions. Within 15 calendar days of the meeting, the ADA Coordinator or his/her designee will respond in writing and, where appropriate, in a format accessible to the complainant, such as large print, Braille, or audio tape. The response will explain the position of the Village and offer options for substantive resolution of the complaint.

If the response by the ADA Coordinator or his/her designee does not satisfactorily resolve the issue, the complainant and/or his/her designee may appeal the decision within 15 calendar days after receipt of the response to the Village Manager or his/her designee.

Within 15 calendar days after receipt of the appeal, the Village Manager or his/her designee will meet with the complainant to discuss the complaint and possible resolutions. Within 15 calendar days after the meeting, the Village Manager or his/her designee will respond in writing and, where appropriate, in a format accessible to the complainant with a final resolution of the complaint.

All written complaints received by the ADA Coordinator or his/her designee, appeals to the Village Manager or his/her designee, and responses from these two offices will be retained by the Village for at least three years.

A.02 GRIEVANCE FORM

Copies of the following grievance form will be made available at Village Hall or provided upon request from a member of the public.

Please fill out this form completely. Please note that this ADA notification procedure is for facilities, services, and programs owned or operated by the Village of Orland Park.			
Name (complainant):			
Address:			
Contact Numbers:	Home:	Work:	Mobile:
E-mail address:			
Reason for grievance/complaint or why you feel you have been discriminated against. The complaint should be in writing and contain information about the alleged discrimination such as name, address, and phone number of complainant, and location, date, and description of the problem. Use a separate sheet if more space is needed.			
State if you require an alternative for any written follow-up communications:			
Signature:		Date:	
This form shall be submitted to: Ahmad Zayyad, Assistant to the Village Manager/Risk Manager 14700 South Ravinia Avenue Orland Park, IL 60462 Phone: (708) 403-6245 Email: azayyad@orlandpark.org			
If you have questions about this form, need an accommodation, or a different format, please contact Ahmad Zayyad, Assistant to the Village Manager/Risk Manager.			

**Chapter 2 Addendum:
Title II Checklist
(ADA Coordinator, Notice & Grievance Procedure)**

PURPOSE OF THIS CHECKLIST: This checklist is designed for use as an assessment of (1) the requirements and tasks of an ADA Coordinator, (2) the government entity's provision of the ADA notice, and (3) the government entity's ADA grievance procedures.

MATERIALS AND INFORMATION NEEDED: To assess compliance with these administrative requirements, you will need:

- ✓ a copy of the written position description for an ADA Coordinator, if applicable;
- ✓ information about the procedures followed by the ADA Coordinator to ensure compliance with the ADA, how complaints are processed, and other tasks performed by the ADA Coordinator;
- ✓ a copy of the written notice or notices used by the state or local government; and
- ✓ a copy of the written grievance procedures used by the state or local government.

ADA Coordinator

1. Does the state or local government have an ADA Coordinator? All state and local governments with 50 or more employees are required to designate at least one responsible employee to coordinate ADA compliance.

- Yes, the state or local government has an ADA Coordinator.
- No, the state or local government does not have an ADA Coordinator but an ADA Coordinator is not required because the public entity has fewer than 50 employees, including all part-time and full-time employees.
- No, the state or local government does not have an ADA Coordinator even though it has 50 or more employees.

ACTIONS:

If the local government has fewer than 50 employees, it is not required to have an ADA coordinator. **HOWEVER**, it is strongly recommended that an ADA coordinator be appointed.

If the state or local government has 50 or more employees, it must have a designated ADA Coordinator. Any state or local government that does not have an ADA coordinator is in violation of federal law. An ADA Coordinator must be designated.

2. Does the ADA Coordinator have the time and expertise necessary to coordinate the government's efforts to comply with and carry out its responsibilities under the ADA?

- Yes
 No

3. Does the ADA coordinator actually carry out these duties?

- Yes
 No

4. Does the ADA Coordinator investigate all complaints communicated to the government alleging that the government does not comply with the ADA?

- Yes
 No

5. Does the government make available to all interested people the name, office address, and telephone number of the ADA Coordinator?

- Yes
 No

ACTIONS:

If you checked "no" for any of the questions above, here are some steps you can take to improve the coordination of your ADA compliance:

- ✓ Ensure that the ADA Coordinator has the time and expertise necessary to coordinate the government's efforts to comply with and carry out its responsibilities under the ADA.
- ✓ Ensure that the ADA Coordinator actually carries out these duties.
- ✓ Ensure that the ADA Coordinator investigates all complaints communicated to the government alleging that the government does not comply with the ADA.
- ✓ Make available to all interested people the name, office address, and telephone number of the ADA Coordinator.

Notice

1. Does the state or local government make information available to the general public regarding the fact that the ADA applies to the services, programs, and activities of the government?

- Yes
 No

2. Does the state or local government use the Department of Justice's model "Notice Under the Americans with Disabilities Act" or a similarly comprehensive notice?

- Yes
 No

3. Does the state or local government post this information in public areas or make it available in other ways as deemed necessary by the head of the government entity to inform people of the protections of the ADA?

- Yes
 No

4. Is the ADA notice available in alternate formats – *i.e.*, large print, Braille, audio format, accessible electronic format (e.g., via email, in HTML format on its website)?

- Yes
 No

ACTIONS:

If you checked "no" for any of the questions above, your office may be violating the requirement for providing notice.

- ✓ Make information available to all interested members of the general public regarding the prohibition of discrimination against people with disabilities.
- ✓ Consider using the Department of Justice's model "Notice Under the Americans with Disabilities Act," or use a similarly comprehensive notice.
- ✓ Make this information available by posting it in common areas of public buildings, posting it on the government's website, or otherwise disseminating it as necessary to inform the public of the ADA's protections.
- ✓ Make the ADA notice available in alternate formats.

Grievance Procedures

1. Does the state or local government have a grievance procedure? All state and local governments with 50 or more employees are required to adopt and publish grievance procedures providing for prompt and fair resolution of complaints of discrimination on the basis of disability.

- Yes, the state or local government has a grievance procedure.
- No, the state or local government has fewer than 50 employees, including all part-time and full-time employees, and is not required to have a grievance procedure.
- No, the state or local government does not have a grievance procedure even though it has 50 or more employees.

2. Does the local government use the Department of Justice's model "Grievance Procedure under the Americans with Disabilities Act" or a similarly comprehensive grievance procedure (*i.e.*, a grievance procedure for complaints made by any member of the public under the ADA related to any program, service, or activity)?

- Yes
- No
- Not applicable, no grievance procedure is required because the public entity has fewer than 50 employees.

3. Is the grievance procedure available in alternate formats?

- Yes
- No

ACTIONS:

If the local government has fewer than 50 employees, it is not required to have a grievance procedure. **HOWEVER**, it is strongly recommended that a grievance procedure be adopted and published by all localities subject to title II of the ADA.

If the state or local government has 50 or more employees, it must have a published grievance procedure. Any state or local government that does not have a grievance procedure is in violation of federal law. A grievance procedure must be adopted and published.

- ✓ Consider using the Department of Justice's model "Grievance Procedure under the Americans with Disabilities Act," or use a similarly comprehensive grievance procedure.
- ✓ Provide copies of your procedure in alternate formats upon request.

APPENDIX C
GENERAL EFFECTIVE COMMUNICATION CHECKLIST

**Chapter 3 Addendum:
Title II Checklist
(General Effective Communication)**

PURPOSE OF THIS CHECKLIST: This checklist is designed for use as an assessment of a **state or local government's provision of effective communication.**

MATERIALS AND INFORMATION NEEDED: To assess compliance with the general effective communication requirements, you will need:

- ✓ a copy of any policies or procedures related to providing sign language interpreters, oral interpreters, cued speech interpreters, notetakers, computer-aided transcription services, etc., when requested by members of the general public. If different departments have different policies, you should review each of the policies.
- ✓ a list of printed materials provided to the public by the locality and an indication of whether these materials are provided, upon request, in an accessible format, such as in large print, Braille, or audio recording.
- ✓ a list of any videos or television programs produced by the locality and an indication of whether these videos or programs have captioning and audio descriptions.
- ✓ a list of where teletypewriters (TTYs) are provided by the locality.
- ✓ a copy of any training materials used in training government employees about providing effective communication to members of the general public whose disabilities affect communication.

Interpreters (Sign Language, Oral, and Cued Speech)

1. Does each department of your state or local government have a policy and procedures in place to deal with requests from the general public for sign language, oral, and cued speech interpreters?

- Yes
 No

2. If policies and procedures are in place, do they:

a. Specify that sign language, oral, and cued speech interpreters can be obtained within a short period of time when necessary? (For example, when needed for hospital emergency rooms, interpreters should be available either in person or by using video relay systems within a reasonable period of time, 24 hours a day, 7 days a week – in this setting, reasonable usually means within an hour of a request. In non-emergency situations, a public entity can require reasonable advance notice for interpreter requests.)

- Yes
 No

b. Make clear that it is generally inappropriate to request family members and companions of deaf persons to serve as sign language interpreters?

- Yes
 No

c. Specify that deaf persons requesting interpreters should not be charged for the cost of the interpreter?

- Yes
 No

- d. Specify that the public entity's decision to deny an interpreter based on undue financial and administrative burden must be made after considering all resources available for use in funding the operation of the program and must be accompanied by a written statement of the reasons for reaching the conclusion?

Yes
 No

- e. Specify that, in any instance where the provision of an interpreter would result in an undue financial and administrative burden, the entity will take any other action that would not result in an undue financial and administrative burden but would nevertheless ensure that the individual with a disability receives the benefits or services provided?

Yes
 No

3. Does your state or local government have employees on staff who are qualified interpreters or have arrangements with one or more vendors to provide interpreting services when needed?

Yes
 No

4. Have the employees who interact with the public been trained on the correct procedures to follow when a person requests an interpreter?

Yes
 No

5. Review documentation and speak with agency personnel responsible for responding to requests for interpreter services. When requests for interpreters have been made in the past, were they granted:

- a. For events such as meetings, interviews, hearings, medical appointments, court proceedings, and training and counseling sessions?

Yes
 No

- b. Without the state or local government asking the individual who requested the interpreter to pay for the services?

Yes
 No

ACTIONS:

If you checked "no" to any of the questions above, these are red flags indicating that your state or local government may not be complying with the effective communication requirements of Title II of the ADA.

- ✓ If your entity does not have policies and procedures on the provision of interpreters, they need to be established.
- ✓ If your entity has policies and procedures, make sure they include the following provisions:
 - ▶ Sign language, oral, and cued speech interpreters can be obtained within a short period of time when necessary. In emergency situations, sign language interpreters will be available either in person or by using video relay systems within a reasonable period, 24 hours a day, 7 days a week – usually, within an hour of receiving the request. In non-emergency situations, sign language interpreters will be available when reasonable advance notice is provided.
 - ▶ Family members and companions of deaf persons will not be asked to serve as sign language interpreters.

- ▶ Deaf persons requesting interpreters will not be charged or asked to pay for the cost of an interpreter.
 - ▶ In situations where agency personnel believe that an undue financial and administrative burden may be involved, the decision to deny an interpreter will be made considering all funding available for the operation of the program.
 - ▶ Where undue financial and administrative burden is the basis for the denial of an interpreter, the agency will take any other action that would not result in an undue financial and administrative burden but would ensure that the individual with a disability receives the benefits or services provided.
- ✓ Make the policy and procedures on the provision of interpreters available to your employees and the public by posting it on your entity's website.
 - ✓ Train employees so they know the policies and the appropriate procedures to follow when they receive a request for an interpreter.
 - ✓ Make arrangements with vendors or hire employees so interpreters are available when needed.

Other Auxiliary Aids and Services

6. Does your state or local government have policies and procedures in place to deal with requests from the general public for documents in Braille, large print, audio recording, and accessible electronic format (that is, an email or compact disc containing the document in plain text, word processing format, HTML or some other format that can be accessed with screen reader software)?

- Yes
- No

7. Does your state or local government have policies and procedures in place to deal with requests from the general public for notetakers, computer-assisted real-time transcription services, and other auxiliary aids and services for providing effective communication?

- Yes
 No

8. Does your state or local government have the equipment or arrangements with vendors so it can provide written materials in alternative formats (e.g., Braille, large print, audio format, electronic format)?

- Yes
 No

9. Does your state or local government provide written materials in alternative formats when asked to do so? (For example, does your entity communicate with blind people by using Braille, large print, or email when asked to do so?)

- Yes
 No

10. Does your state or local government give primary consideration to the requests of the person with a disability when determining what type of auxiliary aid or service to provide?

- Yes
 No

11. Does your entity ensure that all videos and television programs it produces and all videos it makes available to the public on its internet website are available with captioning and audio description?

- Yes
 No

ACTIONS:

If you checked "no" for any of the questions above, your state or local government may not be providing effective communication. Consider taking the following steps:

- ✓ Ensure that policies and procedures are in place to provide auxiliary aids and services needed to ensure effective communications. Policies and procedures should address common requests, such as (1) making documents available upon request in Braille, large print, audio recording, and an accessible electronic format, and (2) providing notetakers, computer-aided real-time transcription, assistance in reading and completing forms, and other common auxiliary aids and services. See the list of common auxiliary aids and services on page 3 of Chapter 3.
- ✓ Ensure that your entity's policies and procedures require decision makers to give primary consideration to the auxiliary aid or service requested by the person with a disability when deciding which auxiliary aid or service to provide.
- ✓ Purchase equipment or make arrangements with vendors so that documents can be provided in alternative formats when requested.
- ✓ Make all videos and television programs that your entity produces, distributes, or makes available to the public accessible to people with hearing and vision disabilities by providing captioning and audio description of important visual images, unless doing so would be a fundamental alteration of your program or impose an undue financial and administrative burden.
- ✓ Train your entity's employees who interact with the public so they know what to do when they receive a request for an auxiliary aid or service.
- ✓ Publish your effective communication policy on the entity's website in an accessible format so people with disabilities know about any reasonable advance notice requirements that your entity adopts.
- ✓ Meet with people in your community who have different disabilities to find out how well your entity's effective communication policies and procedures are working and to solicit suggestions for improvement.

TTYs

12. Where telephones are available to the public for making outgoing calls, are TTYs available for people with hearing and speech disabilities?

- Yes
 No

13. Does your state or local government handle calls placed using a Telecommunications Relay Service or a Video Relay Service in the same way as other telephone calls?

- Yes
 No

ACTIONS:

If you checked "no" for either of the questions above, your entity may be violating the requirement for providing equally effective telecommunication systems for people with hearing and speech disabilities.

- ✓ Provide access to a TTY wherever telephones are available for making outgoing calls.
- ✓ Provide written policies and training to employees who answer the telephone to ensure that incoming calls made through a relay service are handled as quickly and effectively as other calls.
- ✓ Meet with deaf people in your community to find out their experiences when using a relay service to call your entity.

APPENDIX D
9-1-1 AND EMERGENCY COMMUNICATIONS SERVICES CHECKLIST

**Chapter 4 Addendum:
Title II Checklist
(9-1-1 and Emergency Communications Services)**

PURPOSE OF THIS CHECKLIST: This checklist is designed to **identify common problems with the accessibility of a state or local government's 9-1-1 and emergency communications services.**

MATERIALS AND INFORMATION NEEDED: To identify common problems in complying with the effective communication requirements for 9-1-1 and emergency communications services, you will need:

- ✓ a written description of equipment used by 9-1-1 and other emergency communications services (e.g., police, fire, ambulance, poison control) and how that equipment handles TTY calls;
- ✓ a copy of any policies or procedures regarding how your emergency communications services handle silent, open line calls;
- ✓ a copy of any materials used in training emergency communications call takers about TTYs and the handling of TTY calls and information about the frequency of such training;
- ✓ a copy or description of your emergency communications service's policy regarding maintenance and back-up of TTY equipment and the policy regarding maintenance and back-up of equipment for handling standard voice telephone calls;
- ✓ a copy of your emergency communication service's policy regarding testing of TTY equipment and the handling of TTY calls and policy regarding testing of standard voice call-taking equipment and the handling of standard voice calls;
- ✓ the results of unannounced test calls made to your emergency communications services telephone number with a TTY;

- ✓ statistics for response time to standard voice calls as compared to TTY calls received by the service (if you cannot identify which emergency calls were TTY calls, use the response time for unannounced TTY test calls); and
- ✓ feedback from meetings with community members who are deaf, are hard-of-hearing, and have speech disabilities to find out about their experiences in contacting 9-1-1 and emergency communications services and to keep abreast of the communication technology individuals with these disabilities will have available when they attempt to access emergency services when at home or away.

TTY-Compatible Equipment

1. Do you have a TTY or TTY-compatible equipment at every emergency communications services call-taking position?

- Yes
 No

2. Do you have procedures for maintaining TTYs and TTY-compatible equipment that are as effective as the maintenance procedures for voice telephone equipment?

- Yes
 No

3. If you have a plan for back-up equipment in case of equipment malfunctions, telephone line malfunctions, or power failure, does that plan cover TTY calls and equipment?

- Yes *for 911 calls*
 No

ACTIONS:

If you checked "no" to any of the preceding questions, your office may be violating the requirement for providing equally effective emergency communications services.

- ✓ Ensure that a working TTY or TTY-compatible equipment is provided at every emergency communications position.
- ✓ Develop procedures for maintaining TTYs and TTY-compatible equipment that are as effective as the maintenance procedures for voice telephone equipment.
- ✓ If you have a plan for back-up equipment in case of equipment malfunctions, telephone line malfunctions, or power failure, ensure that the plan covers TTY calls and equipment.

Equal Access

4. Is the response time of the telephone emergency services provided for TTY users equal to the response time of the services provided to others?

- Yes
 No

5. Is the response quality of the telephone emergency services provided for TTY users equal to the response quality of the services provided to others?

- Yes
 No

6. Are the hours of operation of the telephone emergency services provided for TTY users equal to the hours of operation of the services provided to others?

- Yes
 No

7. If the telephone emergency services provide additional features (such as automatic number identification, automatic location identification, automatic call distribution), are the features provided to TTY users equal to the features provided to others, whenever feasible? (Feasibility should be determined based on the availability of technology in the marketplace to perform the function for communications received from TTY users.)

- Yes
 No

8. Do call takers respond to each silent, open line call by querying the line with a TTY?

- Yes
 No

9. Can all call takers easily switch back and forth between TTY mode and voice mode during a call?

- Yes
 No

ACTIONS:

If you checked "no" for any of the questions above, your office may be violating the requirement for providing equally effective emergency communications services.

- ✓ Ensure that telephone emergency services provided for TTY users are equal in response time to services provided to others.
- ✓ Ensure that telephone emergency services provided for TTY users are equal in response quality to services provided to others.
- ✓ Provide telephone emergency services to TTY users during the same hours of operation as services provided to others.
- ✓ Ensure that telephone emergency services provided for TTY users are equal in all other features offered (including automatic number identification, automatic location identification, automatic call distribution, etc.).
- ✓ Ensure that call takers respond to each silent, open line call by querying the line with a TTY.
- ✓ Ensure that all call takers can easily switch back and forth between TTY mode and voice mode during a call.

Training

10. Is TTY training mandatory for all emergency communications services personnel who may have contact with individuals from the public who have hearing or speech disabilities?

- Yes
 No

11. Do telephone emergency services require or offer refresher training for TTYs at least as often as they require or offer training for voice calls, and at least every six months?

- Yes
 No

ACTIONS:

If you checked "no" to either of the questions above, your office may be violating the requirement for providing equally effective emergency communications services.

- ✓ Make TTY training mandatory for all personnel who may have contact with individuals from the public who have hearing or speech disabilities.
- ✓ Ensure that telephone emergency services require or offer refresher training for TTYs at least as often as they require or offer training for voice calls, and at least every six months.

Testing

12. Do you test your telephone emergency services to ensure direct, equal access for people using TTYs?

- Yes
- No
- WE DO NOT DO REGULARLY SCHEDULED TESTS; HOWEVER, WE ARE AWARE IMMEDIATELY IF OUR PHONE LINES ARE NOT FUNCTIONING OR IF WE HAVE EQUIPMENT FAILURE.*

ACTIONS:

If you checked "no," your office may be violating the requirement for providing equally effective emergency communications services.

- ✓ Conduct unannounced tests to all call-taking positions and all call takers using both silent, open line calls and calls transmitting TTY tones.
- ✓ Keep records of the results of all test calls. Include the date and time of each call, identification of the call-taking position, whether the call was silent or transmitted tones, whether the caller received a TTY response and the content of the response, the time elapsed and the number of rings from the initiation of the TTY call until the call taker responded by TTY, and whether the call was processed according to your standard operating procedures.

APPENDIX E
WEB SITE ACCESSIBILITY CHECKLIST

Chapter 5 Addendum: Title II Checklist (Website Accessibility)

PURPOSE OF THIS CHECKLIST: This checklist is designed for use in **conducting a preliminary assessment of the accessibility of your agency's website**. The goal is to review your website and your agency's website policies and procedures and see if there are red flags alerting you to ADA accessibility concerns.

MATERIALS AND INFORMATION NEEDED: To assess the accessibility of your website you will need:

- ✓ If already created, a copy of your Website Accessibility Policy.
- ✓ Information describing specific actions taken to make your existing website accessible to people with disabilities.
- ✓ Information about website accessibility training taken by staff and/or contractors responsible for developing and posting webpages and content.
- ✓ Information about any procedures used to obtain input from people with disabilities regarding the accessibility of your website.
- ✓ Any input provided by people with disabilities about their experiences accessing your website.
- ✓ The assistance of your website manager.

Assessing Current Webpages and Content on Your Website

This section will help you determine if your website has some of the most common accessibility problems. It will not identify all website accessibility problems.

1. Does the top of each page with navigation links have a "skip navigation" link? (This feature directs screen readers to bypass the row of navigation links and start at the webpage content, thus enabling people who use screen readers to avoid having to listen to all the links each time they move to a new page.)

- Yes
 No

2. Do all links have a text description that can be read by a screen reader (not just a graphic or "click here")?

- Yes
 No

3. Do all of the photographs, maps, graphics and other images on the website currently have HTML tags (such as an "alt" tag or a long description tag) with text equivalents of the material being visually conveyed?

- Yes
 No

4. Are all of the documents posted on your website available in HTML or another text-based format (for example, rich text format (RTF) or word processing format), even if you are also providing them in another format, such as Portable Document Format (PDF)?

- Yes
 No

5. If your website has online forms, do HTML tags describe all of the controls (including all text fields, check boxes, drop-down lists, and buttons) that people can use in order to complete and submit the forms?

- Yes
- No
- N/A

6. If your website has online forms, does the default setting in drop-down lists describe the information being requested instead of displaying a response option (e.g., "your age" instead of "18 - 21")?

- Yes
- No
- N/A

7. If a webpage has data charts or tables, is HTML used to associate all data cells with column and row identifiers?

- Yes
- No
- N/A

8. Do all video files on your website have audio descriptions of what is being displayed to provide access to visually conveyed information for people who are blind or have low vision?

- Yes
- No
- N/A

9. Do all video files on your website have written captions of spoken communication synchronized with the action to provide access to people who are deaf or hard of hearing?

- Yes
- No
- N/A

10. Do all audio files on your website have written captions of spoken communication to provide access to people who are deaf or hard of hearing?

- Yes
- No
- N/A

11. Have all webpages been designed so they can be viewed using visitors' web browser and operating system settings for color and font?

- Yes
- No

Website Accessibility Policy and Procedures

This section will help you identify potential problems with the ongoing process of ensuring website accessibility.

12. Do you have a written policy on website accessibility?

- Yes
- No

13. Is the website accessibility policy posted on your website in a place where it can be easily located?

- Yes
- No
- N/A

14. Have procedures been developed to ensure that content is not added to your website until it has been made accessible?

- Yes
- No

15. Does the website manager check the HTML of all new webpages to confirm accessibility before the pages are posted?

- Yes
- No

16. When documents are added to your website in PDF format, are text-based versions of the documents (e.g., HTML, RTF, or word processing format) added at the same time as the PDF versions?

- Yes
- No
- N/A

17. Have in-house staff and contractors received information about the website accessibility policy and procedures to ensure website accessibility?

- Yes
- No
- N/A

18. Have in-house and contractor staff received appropriate training on how to ensure the accessibility of your website?

- Yes
- No

19. Have in-house and contractor staff who create web content or post it on your website received copies of the Department of Justice's technical assistance document "Accessibility of State and Local Government Websites to People with Disabilities"?

- Yes
- No

20. If your website contains inaccessible content, is a specific written plan including timeframes in place now to make all of your existing web content accessible?

- Yes
 No
 N/A - website is completely accessible

21. Have you posted on your website a plan to improve website accessibility and invited suggestions for improvements?

- Yes
 No

22. Does your website home page include easily locatable information, including a telephone number and email address, for use in reporting website accessibility problems and requesting accessible services and information?

- Yes
 No

23. Do you have procedures in place to assure a quick response to website visitors with disabilities who are having difficulty accessing information or services available via the website?

- Yes
 No

24. Have you asked disability groups representing people with a wide variety of disabilities to provide feedback on the accessibility of your website?

(Note: Feedback from people who use a variety of assistive technologies is helpful in ensuring website accessibility.)

- Yes
 No

25. Have you tested your website using one of the products available on the Internet to test website accessibility? (Note: Products available for testing website accessibility include no-cost and low-cost options. These products may not identify all accessibility issues and may flag issues that are not accessibility problems. However, they are, nonetheless, a helpful tool in improving website accessibility.)

- Yes
 No

26. Are alternative ways of accessing web-based information, programs, activities, and services available for people with disabilities who cannot use computers?

- Yes
 No

ACTIONS:

If the answer to any of the above questions is "No," there may be accessibility problems with your website. Here are some steps to take to ensure that your website – and the programs and services offered on it – are accessible to people with disabilities.

- ✓ Establish a policy that your webpages will be accessible and create a process for implementation.
- ✓ Check the HTML of all new webpages. Make sure that accessible elements are used, including "alt" tags, long descriptions, and captions, as needed.
- ✓ Ensure that your webpages are designed in a manner that allows them to be displayed using a visitor's own settings for color and fonts.
- ✓ If images are used, including photos, graphics, scanned images, or image maps, make sure to include text equivalents for them, using "alt" tags and/or long descriptions for each. Ensure that the text equivalents convey the meaningful information presented visually by the image.
- ✓ If you use online forms and tables, make those elements accessible.

- ✓ Ensure that videos appearing on your website include appropriately synchronized audio description and captions.
- ✓ When posting new documents on the website, always provide them in HTML or another text-based format (even if you are also providing them in another format, such as PDF). If documents are provided in both formats, provide both formats at the same time so people with disabilities have the same degree of access as others.
- ✓ Develop a plan for making your existing web content accessible, including specific steps and timeframes. Describe your plan on an accessible webpage that can be easily located from your home page. Encourage input on accessibility improvements, including which pages should be given high priority for change. Let citizens know about the standards or guidelines that are being used to provide accessibility. Make accessibility modifications to the more popular webpages on your website a priority.
- ✓ Ensure that in-house staff and contractors responsible for webpages and webpage content development are properly trained on your web accessibility policy and procedures.
- ✓ Provide a way for visitors to request accessible information or services and provide feedback about accessibility problems by posting a telephone number and email address on your home page. Establish procedures to assure a quick response to people with disabilities who use this contact information to access web-based information or services.
- ✓ Periodically enlist people with a variety of disabilities to test your webpages for accessibility and ease of use; use this information to increase your website accessibility.
- ✓ Consider using one of the no-cost or low-cost resources available on the Internet to test the accessibility of your website. (Please note, however, that these products may not identify all accessibility problems on your website.)
- ✓ Ensure that alternative means are available for people with disabilities who are unable to use computers to access information, programs, and services that are normally provided on your website.

**Chapter 7 Addendum 1:
Title II Checklist:
(Emergency Management)**

PURPOSE OF THIS CHECKLIST: This checklist is designed for use as a preliminary assessment of your emergency management programs, policies, procedures, and shelter facilities. The goal is to look at your programs, policies, procedures, and shelter facilities to see if there are any potential ADA problems.

MATERIALS AND INFORMATION NEEDED: To assess the accessibility of your emergency management programs, policies, procedures, and shelter facilities, you will need:

- ✓ a copy of your emergency planning and preparedness documents;
- ✓ a copy of materials used to train employees and volunteers who perform emergency management functions;
- ✓ a copy of materials distributed to the public on emergency preparedness and emergency management and the procedures used for distribution of such materials;
- ✓ a copy of any current contracts or other documents reflecting your relationship with other public entities and/or private organizations to provide any services related to emergency management, such as planning, prevention, preparedness, evacuation, transportation, sheltering, medical services, lodging, housing, response, social services, recovery, clean-up, and remediation;
- ✓ a list of notification methods, procedures, materials, and equipment used to communicate information about emergencies to the public, including people with disabilities (in particular, communication with people who are deaf or hard of hearing and people who are blind or have low vision);
- ✓ a copy of your policies and procedures on emergency notification, evacuation, transportation, emergency shelters, emergency food and medical supplies, temporary lodging and housing, medical services, social services, and other emergency management services;

- ✓ a list of accessible transportation and lodging resources that can be used in an emergency for evacuation, return home following an evacuation, and/or temporary lodging and housing;
- ✓ a list of the facilities designated as emergency shelters, including mass care shelters, special needs shelters, and medical shelters;
- ✓ eligibility criteria, if any, for participation in emergency management programs, services, and activities, including mass care, special needs, and medical shelters; and
- ✓ copies of the "ADA Checklist for Emergency Shelters," located in Addendum 3 to this Chapter and at "<http://www.ada.gov/pcatoolkit/chap7shelterchk.htm>", and survey tools (metal tape measure, electronic (digital) level, pressure gauge, and digital camera).

General Emergency Management Policies and Procedures

1. If you have a contract or other arrangement with any third party entities, such as the American Red Cross or another local government, to provide emergency planning and/or emergency management or response services, does your contract or other documentation of your arrangement contain policies and procedures to ensure that the third-party entities comply with ADA requirements, as outlined in Chapter 7 of this Tool Kit, including Addenda 2 and 3?

- Yes
- No *NO CONTRACTS,*
- N/A

2. Do you have written procedures to ensure that you regularly seek and use input from persons with a variety of disabilities and organizations with expertise in disability issues in all phases of your emergency planning, such as those addressing preparation, notification, evacuation, transportation, sheltering, medical and social services, temporary lodging and/or housing, clean-up, and remediation?

- Yes
- No

3. Do you seek input and participation from people with disabilities and organizations with expertise on disability issues when you stage emergency simulations and otherwise test your preparedness?

- Yes
 No

ACTIONS:

If the answer to any of the above questions is "No," this is a red flag that your emergency management program may not be fully accessible to people with disabilities. Here are some steps to ensure that your emergency management programs, policies, and procedures are accessible to people with disabilities.

- ✓ If your entity contracts or arranges with third party organizations to help with emergency preparedness or management, formalize in your agreements with those organizations their commitment to compliance with the requirements of Title II of the ADA, as set out in this Chapter, including the Addenda.
- ✓ On an ongoing basis, seek and use input from people with different types of disabilities (i.e., mobility, vision, hearing, cognitive, psychiatric, and other disabilities) and organizations with expertise on disability issues regarding all phases of your emergency management plan.
- ✓ When you stage simulations or otherwise test the effectiveness of your emergency planning and preparedness, include people with a variety of disabilities in your testing. For example, enlist people with disabilities to role-play during simulation exercises and provide feedback.

Planning for Emergency Notification and Evacuation

This section helps you identify potential ADA-related problems in your plans for the emergency notification and evacuation of people with disabilities. To ensure an accurate assessment of ADA compliance, this checklist should be completed with the input and assistance of those employees and contractors who are involved in your entity's emergency planning, notification, and evacuation programs, services, and activities.

4. For planning purposes, have you determined the extent to which, in an emergency or disaster, people with disabilities who reside or visit your community are likely to need individualized notification, evacuation assistance, and/or transportation, including accessible transportation?

- Yes
 No

Schools.
DR. OFFICE'S
PRIMARY CARE CENTERS

5. Has your emergency planning identified the resources you will use to meet the needs of individuals with disabilities who require individualized notification, evacuation assistance, and/or transportation, including accessible transportation?

- Yes
 No

FIRE DIST DOES RESCUE + EVAC

6. If your emergency warning systems use sirens or other audible alerts, do you have written procedures to ensure the use of a combination of methods to provide prompt notification of emergencies to persons who are deaf or hard of hearing? (Note: Examples of methods that may be effective in communicating emergencies to people who are deaf or hard of hearing include auto-dialed TTY and taped telephone messages, text messaging, emails, open captioning on emergency broadcasts on local television stations, and dispatching qualified sign language interpreters to assist with emergency announcements that are televised.)

- Yes
 No

7. Does your plan address the needs of people with disabilities who will require assistance leaving their homes?

- Yes
 No

8. Do you have written procedures to ensure that your community evacuation plans enable people with a wide variety of disabilities to safely self-evacuate and, for those who cannot self-evacuate, to receive evacuation assistance? (Note: The plans should address the evacuation

needs of people who have mobility disabilities, people who are blind or have low vision, people who are deaf or hard of hearing, people with cognitive and psychiatric disabilities, people with disabilities who use service animals, and other people with disabilities who reside or visit your community who may need evacuation assistance.)

- Yes
- No

9. Have you established a voluntary, confidential registry for persons with disabilities to request individualized notification, evacuation assistance, and transportation?

- Yes
- No

■ If you maintain such a registry, do you have written procedures to ensure that it is voluntary, it has appropriate confidentiality controls, the information in the registry is regularly updated, and outreach to persons with disabilities and organizations with expertise on disability issues is conducted to inform them of its availability?

- Yes
- No
- N/A

10. Does your emergency transportation plan identify accessible transportation resources that will be available to evacuate persons with mobility disabilities, including people who use wheelchairs or scooters, people who use medical equipment, such as oxygen tanks, and people who use service animals? (Accessible transportation consists of wheelchair lift-equipped vehicles.)

- Yes
- No

FIMS DIST

11. Do your emergency plans, policies, and procedures provide for people with disabilities to be evacuated and transported to shelters together with their families?

- Yes
 No

12. Do your emergency management plans, policies, and procedures ensure that people with disabilities are not separated from their service animals during evacuation and transportation?

- Yes
 No

ACTIONS:

If the answer to any of the above questions is "No," this is a red flag that your emergency management program may not be fully accessible to people with disabilities. Here are some steps to ensure that your emergency notification and evacuation policies, procedures, and programs are accessible to people with disabilities.

- ✓ If you use emergency warning systems such as sirens or audible alerts, provide alternate ways to provide prompt notification of emergencies to people who are deaf or hard of hearing. Combine visual and audible alerts to reach a greater audience than either method would reach by itself. Consider using telephone calls with pre-recorded messages, auto-dialed TTY (teletypewriter) messages, text messaging, emails, and direct door-to-door contact with pre-registered individuals. Also use open captioning on emergency broadcasts on local television stations and dispatch qualified sign language interpreters when emergency announcements are televised.
- ✓ Adopt policies to ensure that your community evacuation plans enable people with disabilities, including those who have mobility, vision, hearing, cognitive, and psychiatric disabilities, to safely self-evacuate or be evacuated by others.
- ✓ Create voluntary, confidential registries of persons with disabilities who may need individualized notification, evacuation assistance, and/or transportation. Establish procedures to ensure that the registries are

voluntary, guarantee confidentiality to those who register, and include a process to periodically update the information contained in the registry. Widely publicize the registries, including outreach to people with disabilities, organizations with expertise on disability issues, organizations that provide services to people with disabilities, and paratransit riders. Outreach should explain the purpose of the registries, provide assurances of confidentiality, explain procedures for registering, and include procedures for people who, because of their disabilities, need assistance in registering.

- ✓ Identify accessible modes of transportation, such as wheelchair lift-equipped school buses, transit buses, paratransit vans, and taxi cabs that will be available to help evacuate people with disabilities during an emergency. Ensure that your plan addresses the needs of people with disabilities, including those who use wheelchairs, scooters, medical equipment, and service animals as well as those who will need assistance getting from their homes to emergency transportation pick-up locations or staging areas.

Training First Responders, Staff, and Volunteers

13. Have the following categories of individuals been trained on the information provided in Chapter 7, including Addenda 2 and 3?
- a. Emergency planners, those who designate facilities to be used as shelters, and those who make advance arrangements to address emergency staffing, equipment, medical supplies, food and beverages, and other emergency-related needs?
 - Yes
 - No

 - b. Staff and volunteers who participate in notification activities?
 - Yes
 - No

c. First responders and other staff and volunteers who deal with evacuation, transportation, and emergency-related security issues?

- Yes
- No

d. Shelter staff and volunteers and those who will be involved in routing people to shelters and deciding shelter placements for people with disabilities and their families?

- Yes
 - No
- REC DEPT. STAFF SHELTERS.*

e. Individuals involved in establishing and operating temporary housing or lodging programs?

- Yes
- No

f. Individuals who will establish and operate emergency-related medical and social service programs?

- Yes
 - No
- Red Cross
D.A.
Hosp.*

g. Individuals who will be responsible for repair, rebuilding, and continuity of program operations following an emergency or disaster?

- Yes
 - No
- P.W. NIMS MODEL.*

ACTION:

If the answer to any of the above questions is "No," this is a red flag that your training programs for emergency management personnel and volunteers may not adequately address access issues for people with disabilities. Here are some steps to ensure that your training policies, procedures, and programs ensure access for people with disabilities.

- ✓ Ensure that emergency planners, those involved in emergency preparedness, first responders, and those involved in all other aspects of emergency management are trained in the requirements of Title II of the ADA, including the information provided in Chapter 7 and Addenda 2 and 3.
- ✓ Develop instructions for staff and volunteers who will perform duties related to emergency notification, evacuation, transportation, and the routing of people with disabilities and their families to, and placement of these individuals in, shelters.
- ✓ Develop site-specific instructions and training materials for "mass care," "medical," and "special needs" shelter volunteers and staff to ensure compliance with ADA requirements to provide access to programs, services, and activities offered at the shelter and to address any concerns raised by people with disabilities. Include in the instructions and training materials, the information in this Chapter, including Addenda 2 and 3 on shelter accessibility, eligibility criteria, effective communication, reasonable modifications in policies, practices, and procedures for service animals, and other reasonable modifications.
- ✓ Train individuals involved in the emergency management process to recognize issues that may affect people with a variety of disabilities and on the procedures to follow when access issues for individuals with disabilities arise during the course of an emergency or disaster, such as contacting your entity's ADA Incident Manager for guidance.

Physical Accessibility in Emergency Shelter Programs

This section helps you identify architectural barriers to access in your emergency shelter facilities. To ensure an accurate assessment of ADA compliance, this

checklist should be completed with the input and assistance of those employees, volunteers, and representatives of third party organizations that are involved in your emergency planning and sheltering programs.

14. Have you conducted an accessibility survey of all of your emergency shelter facilities, whether owned by government or a private entity to determine if they comply with ADA requirements? See "ADA Checklist for Emergency Shelters," included in Addendum 3 to this Chapter.

- Yes
 No

REC DEPT

15. Have you identified access barriers at any of the shelter facilities?

- Yes
 No

REC DEPT.

16. If you found barriers at emergency shelters, have you taken steps to ensure that the barriers are removed to provide (at a minimum) the following accessible features that comply with the requirements of the ADA Standards for Accessible Design (ADA Standards): parking, exterior route from the parking to the entrance, entrance, sleeping area, dining area, toilet facilities, bathing facilities, recreational areas, emergency exit, and interior routes to all of these areas?

- Yes
 No
 N/A

REC DEPT.

17. If all barriers have not been removed from a shelter, have you identified an appropriate number of alternate shelters that provide (at a minimum) the following accessible features that comply with the requirements of the ADA Standards: parking, exterior route from the parking to the entrance, entrance, sleeping area, dining area, toilet facilities, bathing facilities, recreational areas, emergency exit, and interior routes to all of these areas?

- Yes
 No
 N/A

REC DEPT.

18. Until all emergency shelters have the required accessible features referenced above, have you identified and widely publicized to the public and to persons with disabilities and disability organizations the most accessible emergency shelters and the accessible features that each has?

- Yes
- No
- N/A

REC

19. Have you adopted policies and procedures to ensure that shelter staff and volunteers maintain accessible routes for individuals who use wheelchairs and other mobility aids?

- Yes
- No

REC

20. Have you adopted procedures to minimize protruding objects and overhead objects in shelters so that someone who is blind or has low vision can walk safely throughout the shelter?

- Yes
- No

REC

21. Have you adopted policies and procedures for shelter staff and volunteers to offer wayfinding assistance to people who are blind and those with low vision who may need assistance in understanding and navigating the shelter layout and locating shelter facilities (e.g., finding the route to the toilet room when furniture layouts change)?

- Yes
- No

REC

22. Have you established policies and procedures to ensure that, in the future, facilities are surveyed for accessibility and barriers to access are removed before a facility is designated as a shelter?

- Yes
- No

REC

ACTIONS:

If the answer to any of the above questions is "No," this is a red flag that your emergency shelter program may not be fully accessible to people with disabilities. Here are some steps to ensure that your emergency shelters are physically accessible to people with disabilities.

- ✓ Survey your community's shelters for barriers to access for persons with disabilities. At a minimum, survey the parking, the path to the entrance, the entrance, sleeping and dining areas, toilet facilities, bathing facilities, first aid/medical facilities, recreation areas, and the routes to all of these areas. To conduct your survey, use the Department's technical assistance publication, "ADA Checklist for Emergency Shelters," which is included in Addendum 3 to this Chapter.
 - ▶ If you find barriers to access, remove the barriers or work with the facility's owner to remove the barriers.
 - ▶ If barriers cannot be removed, find another nearby facility that is – or can be made – accessible.
 - ▶ Until all emergency shelters have the required accessible features (parking, route to the entrance, entrance, sleeping and dining areas, toilet facilities, bathing facilities, first aid/medical facilities, recreation areas, and the routes to all of these areas), identify and widely publicize the location and features of the most accessible emergency shelters to the public, including specific outreach to persons with disabilities, disability rights organizations, and organizations that provide services to people with disabilities.
- ✓ Adopt procedures to ensure that shelter staff and volunteers maintain accessible routes and minimize protruding objects. Beds and other furniture must be located so as to ensure that accessible routes are not blocked, and that protruding and overhead objects are minimized in all areas of the shelter.
- ✓ Also include procedures for staff and volunteers to offer wayfinding assistance to people who are blind or have low vision to provide orientation to the shelter environment and assistance in locating shelter areas or features.
- ✓ Establish policies and procedures to ensure that facilities being considered as possible emergency shelters in the future are surveyed

for accessibility using the "ADA Checklist for Emergency Shelters" and that barriers to access are removed before facilities are designated as emergency shelters.

Policies and Procedures in Emergency Shelters

23. Do you have supplies of informational materials routinely handed out at emergency shelters available in alternative formats (Braille, large print) for people who are blind or have low vision?

- Yes
- No

24. Have you adopted policies and procedures for shelter staff and volunteers to provide assistance to people who are blind or have low vision by reading and completing forms and other written materials that are not available in alternative formats?

- Yes
- No

25. Do any of your shelters have low-stimulation "stress-relief zones," such as an empty classroom in a school building used as an emergency shelter?

- Yes
- No

■ If you offer "stress-relief zones," have you adopted policies and procedures to make these areas available on a priority basis to people whose disabilities are aggravated by stress?

- Yes
- No
- N/A

26. Have you adopted emergency shelter eligibility policies and procedures to ensure that people with disabilities are housed at "mass care" shelters unless they are medically fragile?

- Yes
 No

Roz Dept

27. Have you adopted "mass care" shelter procedures to ensure that shelter staff and volunteers do not turn away people with disabilities who may need assistance with activities of daily living even though their personal care aides may not be with them?

- Yes
 No

28. Have you adopted policies and procedures to ensure that "mass care," "special needs," and "medical" shelter staff and volunteers are trained and monitored so they provide safe, appropriate assistance with activities of daily living (e.g., eating, dressing, personal hygiene, transferring to and from wheelchairs) that some people with disabilities may require?

- Yes
 No

29. If you provide a "special needs" or "medical" shelter, have you adopted eligibility policies and procedures to ensure that people with disabilities are not housed in such shelters just because they have a disability? (Note: Special needs and medical shelters are for medically fragile people who require the type of care provided in hospitals and nursing homes. Most people with disabilities are not medically fragile. The ADA requires emergency managers and shelter operators to accommodate people with disabilities in the most integrated setting appropriate to their needs.)

- Yes
 No
 N/A

30. Have your shelter staff and volunteers received training with site-specific instructions for providing people with disabilities access to all services, activities, and programs at "mass care," "medical," and "special needs" shelters?

- Yes
- No

31. Do you have written policies and procedures to ensure that people who are deaf or hard of hearing, people with speech disabilities, and people who are blind or have low vision are provided with effective communication during their stay at a shelter?

- Yes
- No

32. Do you provide a TTY at each emergency shelter for use by people who are deaf, are hard of hearing, or have speech disabilities?

- Yes
- No

33. Do you have written procedures to ensure that persons with disabilities who use service animals are not separated from their service animals when using emergency shelters and have full access to shelter programs, services, and activities, even if pets are normally prohibited in shelters or in certain areas of shelters?

- Yes
- No

34. Do you have written procedures to ensure that food, water, and a receptacle and plastic bags for the disposal of service animal waste are available at emergency shelters?

- Yes
- No

35. Have you established security procedures at shelters that allow people with service animals to take their animals outside for relief without unnecessary delays for security screening upon re-entry?
- Yes
 No
36. Do you have written procedures to ensure that emergency shelters have back-up generators and a way to keep medications refrigerated (such as a refrigerator or a cooler with ice)?
- Yes
 No
37. Do your written procedures on back-up generators include a plan for routinely notifying the public and disability groups of the location of shelters providing electricity and refrigeration?
- Yes
 No
38. Does your emergency management plan provide an effective way for people with disabilities to request and receive durable medical equipment and medication while in shelters?
- Yes
 No
39. Have you established procedures for people with disabilities to request and receive cots or beds, modifications to cots or beds, securement of cots or beds to allow safe transfer to a wheelchair, and placement of cots or beds in specific locations when needed?
- Yes
 No

40. Have you adopted kitchen access policies to provide immediate access to food and refrigerated medications for shelter residents and volunteers whose disabilities may require it?

- Yes
- No

41. Does your emergency management plan ensure that at least some kinds of foods and beverages are available in emergency shelters for people with dietary restrictions, such as people who have diabetes or severe food allergies?

- Yes
- No

ACTIONS:

If the answer to any of the above questions is "No," this is a red flag that your emergency shelter program may not be fully accessible to people with disabilities. Here are some steps to ensure that the policies and procedures relating to your emergency shelter programs are accessible to people with disabilities.

- ✓ Adopt procedures to provide effective communication for people who are deaf or hard of hearing, people with severe speech disabilities, and people who are blind or have low vision. Train staff on the basic procedures for providing effective communication, including exchanging notes or posting written announcements to go with spoken announcements. Provide a TTY in each shelter for persons who are deaf, are hard of hearing, or have speech disabilities. Provide interpreters when necessary to ensure effective communication. Train staff and volunteers to read printed information, upon request, to persons who are blind or who have low vision.
- ✓ If space permits, offer low-stimulation "stress-relief zones." Adopt policies and procedures to make these areas available on a priority basis to people whose disabilities are aggravated by stress.
- ✓ Adopt eligibility policies and procedures that ensure that people with disabilities are housed in "mass care" shelters unless they are medically fragile. The procedures should ensure that shelter staff and volunteers accept people with disabilities who need some assistance with activities

of daily living even though their personal care aides may not be with them. Also, provide training and monitoring for staff and volunteers on safe, appropriate procedures for providing assistance in daily living activities to people with disabilities who require such assistance.

- ✓ If you provide a “special needs” or “medical” shelter, adopt eligibility policies and procedures to ensure that emergency managers do not require people with disabilities to stay in these shelters solely because they have a disability. Special needs and medical shelters are intended to house people who are medically fragile, such as those who require hospital or nursing home care. The ADA requires emergency managers and shelter operators to accommodate people with disabilities in the most integrated setting appropriate to their needs.
- ✓ Modify “no pets” policies to allow people with disabilities to stay in shelters – and participate in shelter programs, services, and activities – with their service animals. Also, provide food, water, and waste-disposal supplies for service animals.
- ✓ Ensure that a reasonable number of shelters have back-up generators and a way to keep medications refrigerated (such as a refrigerator or a cooler with ice). Make these shelters available on a priority basis to people whose disabilities require access to electricity and refrigeration. Until all shelters have back-up generators and refrigeration capacity, routinely notify the public about the location of the shelters that have these features.
- ✓ Establish policies and procedures ensuring that people who need electricity for life-sustaining equipment have priority access to it when it is available and that priority access is also provided, where feasible, for people with disabilities who rely on electrically powered mobility devices.
- ✓ Establish policies and procedures, and make advance arrangements for resources to ensure that there is an effective way for people with disabilities to request and receive durable medical equipment and medication.
- ✓ Establish policies and procedures and make advance resource arrangements so that people with disabilities can request cots and beds, modifications to cots and beds, securement of cots and beds, and specific placement of cots, beds, or sleeping mats when needed. In shelters where people will generally be expected to use sleeping mats placed on the floor, ensure that some cots and beds are available for people with disabilities who are unable to use sleeping mats. The

procedures on cots and beds should provide for staff and volunteers to consult with people with disabilities about their needs and provide necessary accommodations.

- ✓ Modify kitchen-access policies so that residents and volunteers whose disabilities may require it can obtain immediate access to food and refrigerated medication. Also, in planning food supplies for shelters, ensure that at least some kinds of foods and beverages are available for people with dietary restrictions, such as diabetes or severe food allergies.

Medical and Social Services

42. Have you established policies and procedures to ensure that medical and social services and other benefit programs are accessible to people with disabilities, including people who use wheelchairs, scooters, and other mobility aids, individuals who cannot leave shelters because of their disabilities, and people who use service animals?

- Yes
- No

CC. Health DEPT.
CC. Animal Control
OP Animal Control

43. Have you established policies and procedures to ensure that application processes for benefit programs are designed so they do not exclude people with disabilities whose disabilities prevent them from using one particular type of application process (e.g., web-based application processes, telephone-based application processes, procedures requiring applicants to have a valid driver's license, or procedures requiring applicants to apply in person)?

- Yes
- No

44. Do you have policies and procedures to ensure that your medical, social service, and other benefit programs provide effective communication to people with disabilities, including people who are deaf or hard of hearing and people who are blind or have low vision?

- Yes
- No

■ Do your policies and procedures include primary consideration of the communication method preferred by an individual with a disability?

- Yes
- No
- N/A

ACTIONS:

If the answer to any of the above questions is "No," this is a red flag that the medical and social services your entity provides may not be fully accessible to people with disabilities. Here are some steps to ensure that the policies and procedures relating to your medical and social services are accessible to people with disabilities.

- ✓ Establish policies and procedures to ensure that medical, social service, and other benefit programs are accessible to people with disabilities, including people who use wheelchairs, scooters, and other mobility aids and people who use service animals.
- ✓ Establish policies and procedures to ensure that medical, social service, and other benefit programs do not have eligibility criteria that screen out or tend to screen out people with disabilities, or application processes or procedures that deny access to people with disabilities.
- ✓ Establish policies and procedures to ensure that medical, social service, and other benefit programs provide effective communication to people with disabilities, including primary consideration of the method of communication preferred by an individual with a disability.

Post-Sheltering Policies and Procedures

45. Have you adopted procedures to provide additional time, transportation, and search assistance for people with disabilities in emergency shelters to locate accessible temporary housing and support services in the community following an emergency?

- Yes
- No

46. If you have a program to provide temporary housing to persons when they leave emergency shelters but cannot yet return home (e.g., housing in dormitories, rooms at lodging facilities, trailers), have you adopted a plan for providing prompt, equivalent temporary housing to persons with disabilities, including accessible housing for people who use wheelchairs, scooters, and other mobility aids and people who are deaf or hard of hearing?

- Yes
- No
- N/A

47. If you have a temporary housing program, do your information materials on temporary housing include information on accessible housing (such as the specific location of accessible hotel rooms within the community or in nearby communities and transportation resources available in that area)?

- Yes
- No
- N/A

ACTIONS:

If the answer to any of the above questions is "No," this is a red flag that your emergency management and post-shelter programs may not be fully accessible to people with disabilities. Here are some steps to ensure that your post-shelter policies, procedures, and programs are accessible to people with disabilities.

- ✓ Modify policies, as necessary, to provide transportation, search assistance, and additional time in shelters to individuals with disabilities who are attempting to locate housing.
- ✓ Identify temporary accessible housing (such as accessible hotel rooms within the community or in nearby communities) that could be used if people with disabilities cannot immediately return home after a disaster. Consider establishing temporary housing procedures to ensure that accessible hotel rooms are available on a priority basis to people with disabilities who need them.
- ✓ Establish policies and procedures to ensure that temporary housing information distributed to the public or to shelter residents includes information on accessible housing and transportation resources.

Post-Emergency Repair, Rebuilding, and Resumption of Program Operations

48. Have you established policies and procedures to ensure that the repair and rebuilding of government facilities comply with the accessibility requirements of Title II of the ADA?
- Yes
 No
49. Have you established policies to ensure that programs relocated from a damaged facility on a temporary or permanent basis remain accessible to people with disabilities?
- Yes
 No

ACTIONS:

If the answer to any of the above questions is "No," this is a red flag that your post-emergency policies and procedures may not be fully accessible to people with disabilities. Here are some steps to ensure that your post-emergency policies and procedures ensure access for people with disabilities.

- ✓ Establish policies and procedures to ensure that facilities constructed or altered because of emergency- or disaster-related damage comply with the accessibility requirements of Title II of the ADA. Facilities constructed after January 26, 1992, and repairs to such facilities, must comply with Title II's new construction requirements. Alterations to facilities constructed before the ADA became effective, must comply with Title II's requirements for alterations to existing facilities. Alterations may not decrease accessibility.
- ✓ Establish policies and procedures to ensure that programs relocated from a damaged facility remain accessible to people with disabilities, whether the relocation is permanent or temporary. Ensure that continuity of operations plans address continuity of access to programs, services, and activities for people with disabilities. Ensure that repair and clean-up activities include the maintenance of accessible features.



**ORLAND PARK POLICE DEPARTMENT
GENERAL ORDER**

ORDER NUMBER: 41-18
SUBJECT: EMERGENCY UTILITIES OUTAGE (HEATING AND COOLING) PROCEDURE
EFFECTIVE DATE: November 1, 2008
AUTHORITY: Timothy J. McCarthy
REVIEW DATE: March 1, 2019
REVIEWER: Deputy Chief of Police and ESDA Coordinator

INDEX AS:

41.18.1 RESPONSIBILITIES

41.18.2 WARMING AND COOLING CENTERS

PURPOSE:

The purpose of this order is to identify the responsibilities and establish procedures associated with providing warming and cooling centers during an emergency utilities outage.

DEFINITIONS:

- Extreme Heat: High temperatures or humid/muggy conditions along with high temperatures which lead to discomfort or health concerns for residents.
- Extreme Cold: Whenever temperatures drop decidedly below normal or below freezing and prolonged exposure to the cold may lead to discomfort or health concerns for residents.
- Warming Center: Warming Centers are heated facilities where a resident can go during periods of extreme cold temperatures to stay warm and safe.
- Cooling Center: Cooling Centers are air-conditioned facilities where a resident can go during periods of extreme heat to stay cool and safe.

ORDER:

41.18.1 RESPONSIBILITIES

- A. In the event of an emergency utility outage, during times of extreme heat or cold, the following procedures will be initiated by the Shift Commander and followed to address the situation:
- a. The Shift Commander will ensure that officers' conduct well being checks of at risk persons in the affected area, based upon the information listed in CAD and in the Emergency Identification Program listed in the Enhanced Field Reporting System.
 - b. Areas experiencing power outages will be toured by Police Officers and Community Service Officers in marked patrol vehicles looking for residents experiencing temperature related problems.
 - c. The on-duty Orland Fire Protection District Battalion Chief at Station One will be notified and will dispatch an ambulance to conduct a tour of the affected area.
 - d. The Orland Park Police Department Community Relations unit will contact Homeowner's Associations and Neighborhood Watch Groups in the affected area to canvas their area for residents needing assistance.

41.18.2 WARMING AND COOLING CENTERS

- A. Any resident found to be suffering from a significant temperature related (heat/cold) situation and not requiring medical assistance will be initially directed or transported to the Orland Park Police Department for warming or cooling. The Shift Commander will notify the Command Staff when such services become necessary. The Shift Commander will make the following spaces available as a temporary warming or cooling center.
- a. The Police Department Lobby

- b. Interview Room 003
- c. The Training Room
- B. If the Police Department facility cannot adequately support the services required or the amount of people becomes too significant to be managed, the "Old Village Hall" will be opened as a warming or cooling center.
- C. The Police Department or "Old Village Hall" warming or cooling center will be initially staffed by the following Police Department personnel:
 - a. Community Service Officer(s)
 - b. ESDA Personnel
 - c. Detention Aide(s)
- D. The Shift Commander shall contact the Recreation Department to assume the duties of these services as soon as possible.
- E. The Shift Commander will monitor conditions to determine if any additional measures are required.
- F. After consultation with the Chief of Police or his designee, the EOC may be activated and an ESDA or police callout may be initiated to open more warming or cooling centers and provide additional monitoring of the affected areas.

*OPPD IS CURRENTLY UPDATING
THIS POLICY.*

3.3.4 TDD Operating Instructions

The TDD machine does not have batteries, therefore when in use it must be placed in the "ON" position.

Answer phone using "Orland Emergency." If there is no response when you answer phone and you hear a TDD motor or if you hear a few tone bursts, proceed as follows:

- 1) Remove dust cover and place TDD power switch to the "ON" position.
- 2) Press "SEND" on TDD indicator and hang up phone.
- 3) Watch "SIGNAL" light (red LED) and wait for it to begin pulsating.
- 4) Hold down the shift-select key while pressing the number two key, this will give you a selection of 0-9 preprogrammed messages.
- 5) Press the number one key, a message should automatically scroll "911, do you need police, fire or medical?"

Continue interrogation as necessary. Type "GA" to tell other party to go ahead and "SK" to end. Ask party to stay on line until help arrives, TDD user to hold use the word "WAIT." Sign off by typing "GA or SK" and wait to receive "SK" back. When call is terminated press the "RESET" button on TDD detector and power switch to "OFF" on TDD machine. Tear off printout from TDD, note date and times, sign printout and forward to Supervisor of Support Services. Printouts should be retained for 30 days.

3.4 Telephone System Operation

Trainee and Training Officer will review the following:

- 1) *Non Emergency Phones*
 - A) Answering phone
 - B) Transferring calls
 - C) Main switchboard phones
 - D) Desk phones
 - E) Message taking
 - F) Personal use
- 2) *E 9-1-1 and Emergency Phones*
 - A) ANI/ ALI display
 - B) Proper answering procedure
 - C) Transfer procedure
 - D) Single button transfer
- 3) *Operational Information*
 - A) Recorded/ Unrecorded lines
 - B) Ring down lines in Radio Room
 - C) Reporting equipment malfunctions
 - D) Telephone numbers and extensions
 - E) Other phone functions:
 - 1) Night 1
 - 2) Non emergency line
 - 3) Release button
 - 4) Hold buttons ... Dial 51 to pick up call on hold
 - 5) Paging system
 - 6) Transferring calls
 - 7) Lighted extension numbers

3.5 TDD Training Regulations

In compliance with ADA and other regulatory agencies, all personnel working in the Orland Park Police Department Communications Center will receive training annual TDD training. This training may be in the form of videos, workbooks, etc.

Trainer _____

Date _____

Trainee _____

Date _____

SUBJECT: EQUIPMENT ORIENTATION

3.3 TDD Overview

3.3.1 General Background Information on the Americans with Disabilities Act

The first legislation mandating TDD CHAPTER was CHAPTER 504 of the Rehabilitation Act of 1973, which required Federal Government Agencies to offer TDD services. The Americans with Disabilities Act (ADA) was signed in July of 1990, with mandatory compliance effective January 26, 1992.

The Act broadly imposes obligations related to building access, employment opportunities, communications and other activities. Title II of the ADA applies to "Public Entities" which are defined in CHAPTER 201, to include "state and local government and any department, agency, special purpose district, or other instrumentality of a state or a state's or local government." Title II broadly requires that no disabled person be "excluded from participation in or be denied the benefits of the services, programs, or activities of a public entity, or be subjected to discrimination by any such entity."

3.3.2 Regulations of the ADA as they Relate to Public Safety Communications

Since January 26, 1992, all public entities that provide telephone emergency services have been required to be accessible to people who have severe speech or hearing disabilities. The ADA mandates that "telephone emergency services, including 9-1-1 services, shall provide direct access to individuals who use TDD's and computer modems." This Act dictates a performance standard which must be met by that public entity. The term "performance standard" refers to specifications of the level of service that must be provided by the agency. This differs from a "technical standard," which mandates or specifies the type of equipment to be used and the number of units that must be placed and kept in service.

3.3.3 Call Detection

This is one of the most critical skills which must be mastered by the telecommunicator, as there is no way to properly handle a call if it is not initially connected. Calls from TDD's and ASCII computer modems will usually be received in one of four ways.

Electronic Tone

If the call is from a Baudot machine and the caller is pressing their space bar there will be an electronic tone heard on the line which signifies the call is TDD.

Silent Call

More often, silence is heard. Therefore, all silent calls should be handled as potential TDD calls. With many TDD's and ASCII receiving modems, tones can be sent over the line to detect the carrier signal from the TDD or ASCII modem. These machines will check for ASCII first, since recognition is time critical, and then Baudot.

Synthesized Voice

A synthesized voice may also alert the call taker that the call is coming from a TDD or ASCII computer modem where it can then be received in the appropriate manner.

Relay Announcement

Finally a relay announcement may come in which also serves to notify the call taker that the call is from a TDD or ASCII modem.

Trainer _____

Date _____

Trainee _____

Date _____



ORLAND PARK POLICE DEPARTMENT GENERAL ORDER

ORDER NUMBER: 41-13
SUBJECT: EMERGENCY WEATHER WARNINGS
EFFECTIVE DATE: 1 July 1998
AUTHORITY: Timothy J. McCarthy
REVIEW DATE: March 1, 2019
REVIEWER: Deputy Chief of Police and E.S.D.A. Coordinator

INDEX AS:

41.13.1 WEATHER WATCHING/SPOTTING PROCEDURES

41.13.2 WEATHER WARNING SIREN LOCATIONS AND MAINTENANCE

41.13.3 WEATHER WARNING SIREN TESTING PROCEDURES

41.13.4 WEATHER WARNING SIREN ACTIVATION POLICY

41.13.5 EVACUATIONS

PURPOSE:

The Severe Weather Procedure has been developed to assist all emergency, non-emergency and telecommunicators in the event of an approaching severe weather front. This procedure identifies and gives direction regarding the necessary steps needed in order to effectively handle those emergencies that may arise during a severe storm. In order for this procedure to work properly, it must be applied early in the WEATHER WATCH mode. This is only a severe weather procedure that could be upgraded into a Disaster Response Plan as weather conditions warrant.

DEFINITIONS:

Forecast: This is a prediction of what events are expected to occur. The range of predictability for hydro meteorological hazards extends from the short-term forecasts for one to two hours out to climatologically forecasts for trends up to a year in advance.

Statement: Detailed follow-up information to warnings, advisories, watches, and outlooks is provided.

Outlook: The potential for a hazard exists, though the exact timing and severity is uncertain. A readiness status is usually designated by the National Weather Service upon the issuance of a Severe Weather Outlook.

Watch: Conditions are favorable for occurrence (development or movement) of the hazard. The National Weather Service will issue a Severe Weather/Tornado Watch, which requires a heightened awareness of responsible authority and the public should stay alert.

Advisory: An event, which is occurring or is imminent, is less severe than a warning. It may cause inconvenience, but is not expected to be life threatening, if normal precautions are taken.

A heightened readiness status is usually implemented by Cook County Emergency Management and Orland Park E.S.D.A. upon the issuance of a Severe Storm Warning by the National Weather Service. This will usually occur when the threat of severe weather is expected to affect the Village of Orland Park and/or southern Cook County or northern Will County within a period of one hour.

Warning: The hazardous event is occurring or is imminent. The issuance of a Tornado Warning by the National Weather Service will be issued when the threat of a tornado is expected to affect the Village of Orland Park and/or surrounding area within a certain time period. Issuance of a Tornado Warning may also require the activation of the Orland Park Emergency Weather Warning Siren System.

Flood Watch: High flow or overflow of water from a river is possible in the given time period. It can also apply to heavy runoff or drainage of water into low-lying areas. These watches are generally issued for flooding that is expected to occur at least 6 hours after heavy rains have ended.

Flood Warning: Flooding conditions are actually occurring or are imminent in the warned area.

Flash Flood Watch: Flash flooding is possible in or close to the watch area. Flash Flood Watches are generally issued for flooding that is expected to occur within 6 hours after heavy rains have ended.

Flash Flood Warning: Flash flooding is actually occurring or imminent in the warned area. It can be issued as a result of torrential rains, a dam failure, or ice jam.

Funnel Cloud: This is a violently rotating column of air. It will appear as a funnel shaped tail that may be dipping up and down and spinning rapidly, but has not touched the ground.

Severe Weather / Tornado Watch: A watch is an indication of where and when the probabilities are highest that severe weather or a tornado could occur. A WATCH is a statement that severe weather / tornado conditions are present and could occur. The National Weather Service will issue a watch bulletin to local authorities as well as to the local radio and TV stations.

Severe Weather Warning / Tornado Warning: A warning means that a severe thunderstorm or tornado is imminent or is already occurring. When warnings are issued for the area, residents should be encouraged to take immediate action.

Severe Thunderstorm: Any thunderstorm possessing one or more of the following: winds greater than 50 knots (50m.p.h.), hail 3/4 inches in diameter or larger, or a tornado.

Wall Cloud: This is the lowering of a cloud on the southwest rain free base of a thunderstorm. It is from a wall cloud that a funnel or tornado will develop.

Tornado: A violently rotating column of air associated with a parent cumulonimbus cloud and is in contact with the ground. Tornadoes usually rotate counter-clockwise in the Northern Hemisphere and may not always have a visible funnel.

Blizzard Warning: Heavy snow and strong winds will produce a blinding snow, near zero visibility, deep drifts and life-threatening wind chill.

Freezing rain: Rain that freezes when it hits the ground, creating a coating of ice on roads and walkways.

Frost/Freeze Warning: Below freezing temperatures are expected.

Sleet: Rain that turns to ice pellets before reaching the ground. Sleet also causes roads to freeze and become slippery.

Winter Storm Warning: Severe winter conditions have begun or will begin very soon.

Winter Storm Watch: Severe weather such as heavy snow or ice is possible in the next day or two.

Winter Weather Advisory: Cold, ice and snow are expected.

TDD: Telephone Device for the Deaf.

ORDER:

41.13.1 WEATHER WATCHING / SPOTTING PROCEDURES

A. Responsibility

The primary responsibility for the training, deployment and reporting of all official severe weather spotters of the Village of Orland Park shall rest with the Coordinator of the Emergency Services and Disaster Agency (E.S.D.A.) of the Orland Park Police Department, or his designee.

1. All official weather spotters deployed by the Orland Park E.S.D.A. shall receive the requisite training for such responsibilities in conformance with the guidelines established by the National Weather Service.

B. Activation Notification and Deployment

If threatening weather is approaching by sight, notification by IEAM, LEADS, weather tones, or by monitoring television and/or radio, the on-duty shift commander has the responsibility to immediately notify the ESDA Coordinator of the threatening weather conditions.

If/when the weather related information is received by the ESDA Coordinator or designee, they will in turn notify the on-duty shift commander. Notifications, if warranted, will proceed up through the chain of command to include the Village Manager to insure a proper response to the weather conditions will be met in a timely manner.

1. The ESDA Coordinator will register with the National Weather Service to receive notification regarding Severe Weather Conferences. The ESDA Coordinator will participate in teleconferences and disseminate severe weather information effecting Orland Park in a timely manner to the following:
 - a. Police Shift Commander
 - b. Police Command Staff
 - c. Fire Districts (Orland, Palos and Mokena)
 - d. Public Works

C. Notification

1. Severe / Tornado Watch
 - a. Whenever the NWS issues a SEVERE WEATHER /TORNANDO WATCH, (conditions are favorable for occurrence) the E.S.D.A. Coordinator, or designee, shall monitor the National Weather Service (NWS) reports for continual weather condition updates.
 - b. The Coordinator shall also place the E.S.D.A. staff and/or weather spotters on alert.
 - c. The ESDA Coordinator will then make notification to the Chief of Police or designee who in turn will notify the Village Manager advising of the Severe Weather Watch, and the likely weather conditions.
2. Severe Weather Advisory / Tornado Advisory
 - a. In the event that weather conditions continue to develop and the NWS detects an increasing amount of weather data indicating a probability that severe weather is imminent, the NWS will issue a SEVERE WEATHER TORNADO ADVISORY.
 - b. If an Advisory is issued, the E.S.D.A. Coordinator will activate all the ESDA staff to report to the Orland Park Emergency Operations Center (EOC). If deemed necessary, weather spotters will be deployed to the area where the storm is developing.
 1. Weather spotters shall position themselves at a distance of at least two miles outside the village limits in the area of the developing storm to provide sufficient warning of a tornado, funnel cloud, or severe winds causing structural damage.
 - c. The ESDA Coordinator will also make notification to the Chief of Police or designee who in turn will notify the Village Manager regarding the continued development of severe weather and the issuance of a Severe Weather Advisory.
3. Severe Weather Warning
 - a. Should weather conditions continue to deteriorate and a hazardous storm is occurring or is imminent that will likely affect the Village of Orland Park and/or Southern Cook and/or Northern Will County, the NWS will issue a SEVERE WEATHER WARNING.
 - b. When this status is reached, the E.S.D.A. Coordinator and if necessary the Shift Supervisor shall deploy weather spotters outside the boundaries of the Village of Orland Park to include:
 - 1) Route 6 and Parker Rd,
 - 2) 159th St. and Parker Rd. and
 - 3) 143rd St and Parker Rd.
 - c. Once deployed, weather spotters shall report directly to their assignments and maintain radio contact with the OPPD communication center or the EOC if manned.

- d. Spotters will report any and all weather related developments based upon their training and observations.
- e. The E.S.D.A. Coordinator, or designee will continue to monitor the weather radar as it may provide valuable data in the prediction of developing severe weather conditions.
- f. The ESDA Coordinator will make notification to the Chief of Police or designee who in turn will notify the Village Manager regarding the possible development of severe weather and the issuance of a Severe Weather Warning.

4. Tornado Warning

- a. In the event that weather conditions are developing that produce a high probability that a tornado may develop within the immediate area, the NWS will usually issue a TORNADO WARNING.
- b. Upon the issuance of a TORNADO WARNING or during a severe weather incident, the Emergency Warning Siren System should be activated in the event of one of the following:
 - i. A CONFIRMED sighting of a tornado, or funnel cloud aloft by a trained weather spotter within five (5) miles of the village.
 - 1. This five-mile perimeter should be extended geographically around the perimeter of the village from the farthest northern, southern, eastern and western borders at a minimum.
 - 2. Towns within this five-mile perimeter include Oak Lawn, Hickory Hills, Chicago Ridge, Worth, Palos Hills, Palos Park, Palos Heights, Alsip, Midlothian, Oak Forest, Markham, Crestwood, Country Club Hills, Matteson, Tinley Park, Frankfort, Mokena, New Lenox, Lockport Lemont & portion of unincorporated Will County & Cook County
 - ii. A CONFIRMED sighting by a trained weather spotter of severe winds causing structural damage within five (5) miles of the village.
 - iii. A CONFIRMATION of severe winds in excess of 70 miles per hour within the village.
 - iv. The receipt of a tornado warning, issued by the National Weather Service, indicating that Orland Park is in the direct path of the oncoming tornado.
- c. The Shift Supervisor will notify the Chief of Police or designee who in turn will notify the Village Manager regarding the activation of the Emergency Weather Warning Siren System.
- d. At any time when the Emergency Weather Warning siren system is activated, other than for testing, the TCO activating the Emergency Weather Warning will create an incident indicating why the siren was activated and under who's authority.
- e. The on-duty back-up TCO will contact the National Weather Service (Chicago) at 1-800-681-2972 or 815-834-0666 and advise them of any or all of the following:
 - i. A CONFIRMED sighting of a tornado, or funnel cloud aloft by a trained weather spotter within five (5) miles of the village,
 - ii. A CONFIRMED sighting by a trained weather spotter of severe winds causing structural damage within five (5) miles of the village and/or
 - iii. A CONFIRMATION of severe winds in excess of 58 miles per hour within the village.
 - iv. Storm Damage meeting any of the criteria:
 - (1) Damage to structures (roof, siding, windows, etc),
 - (2) Damage to vehicles (hail or wind),
 - (3) Trees or large limbs down,
 - (4) Power/telephone poles or lines down,
 - (5) Flooding that impacts roads, homes, or businesses or

(6) Hail quarter size or larger.

- f. The on-duty back-up TCO, clerical staff member, available Detention Aide or CSO will be assigned the responsibility to notify the below dispatch centers, via telephone and/or LEADS, informing them of our siren system activation.
 - i. Tinley Park P.D.
 - ii. Oak Forest P.D.
 - iii. Southwest Central Dispatch
 - iv. Lincolnway Dispatch
 - v. Cook County Sheriff's Police
 - vi. Will County Sheriff's Police

This will insure that surrounding towns are aware of a potential threat to their communities.

- g. Callers requesting information regarding the activation of the Emergency Weather Warning System will be transferred to the designated voice mail box # 5999.
 - i. The Supervisor of Support Services or designee will record the message that citizens will receive when they call inquire as to why the Emergency Weather Warning Siren was activated.
 - ii. The recorded message will advise them to take immediate action to protect their families, stay indoors and monitor radio or television for emergency broadcast information. The message will also advise them that Orland Park DOES NOT issue an "all clear" by activating the sirens and/or any other reason as to why the siren system was activated.

5. Disaster Plan Activation

- a. In the event of an actual Tornado or severe weather related damage within the village, the Mayor may activate the Village of Orland Park Disaster Plan.
- b. Upon activation of the Disaster Plan, all Department Directors will immediately report to the EOC.

41.13.2 WEATHER WARNING SIREN LOCATIONS AND MAINTENANCE

- A. The E.S.D.A. Coordinator shall plan and provide for the appropriate maintenance of the Village of Orland Park Emergency Warning Siren System.
 - 1. Contract, preventative and repair maintenance services shall be arranged and budgeted for through a competent vendor, upon the approval of the Chief of Police.
- B. A complete listing of all Emergency Warning Siren Locations may be found in Attachment "A" of this order.

41.13.3 WEATHER WARNING SYSTEMS TESTING PROCEDURES

A. Warning Siren Testing

Emergency Weather Warning Siren System shall be activated for testing purposes on the first Tuesday of each month at 1000 hours.

B. TDD Warning Pager System

The Emergency Weather Warning TDD Pager System shall be activated for testing purposes on the first Tuesday of each month immediately following the siren test at 1000 hours.

1. Procedure

- a. Dial appropriate telephone number.
- b. When the tones sound (three beeps) dial the test code activation numbers - 888.
- c. Hang up the telephone.

2. Should the Communications Center receive notice from a resident that the test was not received by a TDD pager, or if the pager is in need of repair, the resident should be directed to call the TDD Relay Center at (800) 526-0844 for a referral to the Village Hall.

C. Responsibility

1. Weather Warning Siren and TDD Testing

The Telecommunicator assigned to the "Backup" position on the day of a test shall be responsible to ensure that these weather warning test directives are carried out on a timely basis.

41.13.4 EMERGENCY WEATHER WARNING SIREN AND TDD PAGER ACTIVATION POLICY

A. Authority

Emergency Weather Sirens and TDD Pagers may be activated within the following policy and under the authority of any of the following personnel:

1. Chief of Police, or designee
2. Shift Commander
3. E.S.D.A. Coordinator, his designee or officer in charge.
4. Village President
5. Village Board Member
6. Village Manager, or Assistant Village Manager
7. Any Department Head
8. Orland Fire Protection District Chief, Deputy Chief or Battalion Chief.

B. Procedure - Siren Activation

1. The telecommunicator shall activate the siren by executing the following procedure;
 - a. Select Public Works channel;
 - b. Punch "ALERT/SIGNAL TALK" - sirens will activate and automatically de-activate.

C. Procedure - TDD Pager System

1. System Activation

The TDD Pager System will be activated by dialing the appropriate number. Upon hearing the pager tones the operator will dispatch the appropriate weather warning by depressing the numbers on the telephone touch pad as follow;

- 111 Tornado Watch
 - 222 Tornado Warning
 - 333 Flood Warning
 - 444 Winter Storm Warning/Blizzard Conditions
2. 911 Service Codes
 - 555 911 Service Interrupted
 - 666 911 Service Restored

D. Documentation

Telecommunicators shall create an incident in the CAD System indicating the date, time and authority authorizing the activation of siren system.

E. Responsibility - Weather Warning Siren and TDD Activation

APPENDIX G
BUILDING AND FACILITY CHECKLISTS



ADA Checklist for Readily Achievable Barrier Removal

Based on the 2010 ADA Standards for Accessible Design



Produced by

Institute for Human Centered Design

www.HumanCenteredDesign.org

www.ADAchecklist.org

2011



ADA National Network

www.ADAta.org

Questions on the ADA 800-949-4232 voice/tty

Questions on checklist 617-695-0085 voice/tty

ADAinfo@NewEnglandADA.org

This checklist was produced by the New England ADA Center, a project of the Institute for Human Centered Design and a member of the ADA National Network. This checklist was developed under a grant from the Department of Education, NIDRR grant number H133A060092-09A. However the contents do not necessarily represent the policy of the Department of Education, and you should not assume endorsement by the Federal Government.

Questions or comments on the checklist contact the New England ADA Center at 617-695-0085 voice/tty or ADAinfo@NewEnglandADA.org

For the full set of checklists, including the checklists for recreation facilities visit www.ADAchecklist.org.

ADA Checklist for Readily Achievable Barrier Removal

What is Readily Achievable Barrier Removal?

The Americans with Disabilities Act (ADA) requires public accommodations (businesses and non-profit organizations) to provide goods and services to people with disabilities on an equal basis with the rest of the public.

Businesses and non-profit organizations that serve the public are to remove architectural barriers when it is “readily achievable” to do so; in other words, when barrier removal is “easily accomplishable and able to be carried out without much difficulty or expense.”

The decision of what is readily achievable is made considering the size, type, and overall finances of the public accommodation and the nature and cost of the access improvements needed. Barrier removal that is difficult now may be readily achievable in the future as finances change.

This checklist is intended to assist public accommodations as the first step in a planning process for readily achievable barrier removal.

Public accommodations’ ADA obligations for barrier removal can be found in the Department of Justice’s ADA Title III regulations 28 CFR Part 36.304.

Priorities for Barrier Removal

The ADA Title III regulations recommend four priorities for barrier removal. The purpose of these priorities is to facilitate business planning. The priorities are not mandatory.

How to Use this Checklist

Get Organized - One person can conduct a survey, but it’s easier with two people. One person can take measurements and the other person can fill out the checklist and take photos.

Obtain Floor Plans - A floor plan or sketch helps the surveyors get oriented and know how many elements, such as drinking fountains and entrances, there are and where they are. If plans are not available, sketch the layout of interior and exterior spaces.

Make Copies of the Checklist -

Determine how many copies of each section of the checklist you need. For example, most facilities have more than one toilet room.

Gather Tools -

- Checklist
- Clipboard makes it easier to write on the checklist
- Tape measure
- Electronic or carpenter’s level - 24 inches
- Door pressure gauge or fish scale for measuring door-opening force
- Digital camera
- Bag to hold these items

Public accommodations may determine the most effective mix of barrier removal measures to undertake in their facilities.

Priority 1 - Accessible approach and entrance

Priority 2 - Access to goods and services

Priority 3 - Access to public toilet rooms

Priority 4 - Access to other items such as water fountains and public telephones

2010 ADA Standards for Accessible Design

This checklist is based on the 2010 ADA Standards for Accessible Design (2010 Standards). The specifications are in this checklist to help determine what may be readily achievable barrier removal for existing facilities. This checklist does not include all sections of the 2010 Standards. For example there are no questions about patient rooms in hospitals or guest rooms in hotels. Consult the 2010 Standards for situations not covered in the checklist. Full compliance with the 2010 Standards is required only for new construction and alterations. The web address for the 2010 Standards is in the Resources section.

Safe Harbor – Construction Prior to March 15, 2012

Elements in facilities built or altered before March 15, 2012 that comply with the 1991 ADA Standards for Accessible Design (1991 Standards) are not required to be modified to specifications in the 2010 Standards. For example, the 1991 Standards allow 54 inches maximum for a side reach range to a control such as the operating part of a paper towel dispenser. The 2010 Standards lower that side reach range to 48 inches maximum. If a paper towel dispenser was installed prior to March 15, 2012 with the

Conduct the Survey

Start Outside - Start from site arrival points such as drop-off areas and public sidewalks and determine if there is an accessible route to an accessible entrance. If there is a parking lot or garage check for the correct number of accessible parking spaces, including van-accessible spaces. Is there an accessible route from the accessible parking spaces to an accessible entrance? Next survey the entrances. If there is an accessible entrance, determine if there are signs at inaccessible entrances directing people to the accessible entrance. Go inside and continue through the facility and the checklist.

Keep Good Notes - Write on the front of each checklist where you are surveying. You may end up with six toilet room checklists. When you get back to your office you'll want to know which one is the checklist for the first floor women's room. If there isn't an accessible entrance you'll want to indicate how many steps there are and how much space is available to install a ramp or lift. This is a good time to take photographs.

Take Good Measurements - When in doubt write it down. It's better to have too much information than not enough. Even if something is in compliance it's helpful to have exact measurements.

highest operating part at 54 inches, the paper towel dispenser does not need to be lowered to 48 inches. Since the dispenser complies with the 1991 Standards, that Standard provides a “safe harbor.”

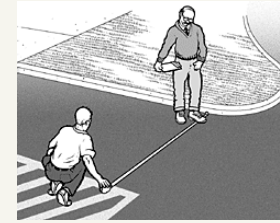
New Elements in the 2010 ADA Standards

The 2010 Standards contain elements that are not in the 1991 Standards. These elements include recreation facilities such as swimming pools, team or player seating, accessible routes in court sports facilities, saunas and steam rooms, fishing piers, play areas, exercise machines, golf facilities, miniature golf facilities, amusement rides, shooting facilities with firing positions, and recreational boating facilities. Because these elements were not included in the 1991 Standards, they are not subject to the safe harbor exemption. Public accommodations must remove architectural barriers to these items when it is readily achievable to do so. For example, a hotel must determine whether it is readily achievable to make its swimming pool accessible by installing a lift, a sloped entry or both as specified in the 2010 Standards.

What this Checklist is Not

The ADA Title III regulations require more than barrier removal. The regulations include requirements for nondiscriminatory policies and practices and for the provision of auxiliary aids and services, such as sign language interpreters for people who are deaf and material in Braille for people who are blind. This checklist does not cover those requirements.

Since this checklist does not include all of the 2010 Standards it is not intended to determine compliance for new construction or facilities being altered.



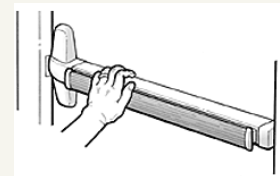
Parking Spaces

Measure from the inside edge of the painted line to the inside of the opposite painted line or edge of space.



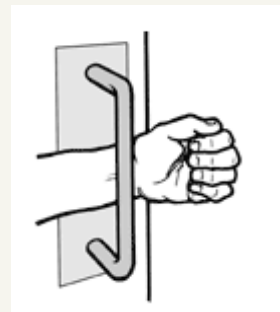
Door Clear Width

Open the door 90 degrees, measure from the face of the door to the edge of the door stop.



Door Opening Force

If you're using a door pressure gauge place it where you would push open the door.



If you're using a fish scale place it where you would pull open the door.

What are Public Accommodations?

Under the ADA public accommodations are private entities that own, lease, lease to or operate a place of public accommodation. This means that both a landlord who leases space in a building to a tenant and the tenant who operates a place of public accommodation have responsibilities to remove barriers.

A place of public accommodation is a facility whose operations affect commerce and fall within at least one of the following 12 categories:

- 1) Places of lodging (e.g., inns, hotels, motels, except for owner-occupied establishments renting fewer than six rooms)
- 2) Establishments serving food or drink (e.g. , restaurants and bars)
- 3) Places of exhibition or entertainment (e.g. , motion picture houses, theaters, concert halls, stadiums)
- 4) Places of public gathering (e.g. , auditoriums, convention centers, lecture halls)
- 5) Sales or rental establishments (e.g. , bakeries, grocery stores, hardware stores, shopping centers)
- 6) Service establishments (e.g. , laundromats, dry-cleaners, banks, barber shops, beauty shops, travel services, shoe repair services, funeral parlors, gas stations, offices of accountants or lawyers, pharmacies, insurance offices, professional offices of health care providers, hospitals)
- 7) Public transportation terminals, depots, or stations (not including facilities relating to air transportation)



Accessible Slopes

You can measure slope with a 24 inch level and a tape measure. Put the level on the surface in the direction you are

measuring. Put one end at the high point of the surface and raise the other end so that the bubble is in the middle of the level's gauge. The level is now level. Measure the distance between the end of the level at its bottom point and the surface.

For a ramp the maximum running slope allowed is 1:12. That means for every inch of height change there should be at least 12 inches of ramp run. If the distance between the bottom of the level and the ramp surface is 2 inches or less, then the slope is 1:12 or less ($2:24 = 1:12$ and $1.5:24 = 1:16$ which is a more gradual slope than 1:12). If the distance is greater than 2 inches, the ramp is too steep. For example, if the distance is 3 inches, then the slope is 1:8 ($3:24 = 1:8$ which is a steeper slope than 1:12).

For the parts of an accessible route that aren't a ramp, the maximum running slope allowed is 1:20. That means for every inch of height change there must be at least 20 inches of route run. The distance from the bottom edge of the level to the surface should be no more than 1.2 inches ($1.2:24 = 1:20$).

- 8) Places of public display or collection (e.g. , museums, libraries, galleries)
- 9) Places of recreation (e.g. , parks, zoos, amusement parks)
- 10) Places of education (e.g. , nursery schools, elementary, secondary, undergraduate, or postgraduate private schools)
- 11) Social service center establishments (e.g. , day care centers, senior citizen centers, homeless shelters, food banks, adoption agencies)
- 12) Places of exercise or recreation (e.g. , gymnasiums, health spas, bowling alleys, golf courses).

Resources

U.S. Department of Justice ADA Information

800-514-0301 voice
800-514-0383 TTY
www.ada.gov

ADA National Network

800-949-4232 voice/TTY connects to your regional ADA Center
www.adata.org

U.S. Access Board

800- 872-2253 voice
800-993-2822 TTY
www.access-board.gov

For the cross slope of an accessible route the maximum slope allowed is 1:48. The distance from the bottom edge of the level to the surface should be no more than ½ inch (.5:24 = 1:48). The cross slope of an accessible route is the slope that is perpendicular to the direction of pedestrian travel.

Slopes may also be measured using a digital level. Be sure to read the instructions. Measure with the percent calculation rather than the degrees calculation. For a ramp the maximum running slope allowed is 8.33% (8.33% is a 1:12 slope). For an accessible route without a ramp the maximum running slope allowed is 5% (1:20). For the cross slope of an accessible route the maximum slope allowed is 2.083% (1:48).

Check that You Got Everything - Before you leave the site review all the checklists. Make sure you know which checklist goes with which entrance and which toilet room and that you've got all the information you need. It is better to do it now than to have to go back.

After the Survey

List Barriers and Solutions - Consider the solutions listed beside each question on the checklist and add your own ideas. Consult with building contractors and equipment suppliers to estimate the costs for making modifications.

ADA Title III Regulations 28 CFR Part 36

www.ada.gov/regs2010/titleIII_2010/titleIII_2010_regulations.htm

2010 ADA Standards for Accessible Design

www.ada.gov/2010ADASTandards_index.htm

1991 ADA Standards for Accessible Design

www.ada.gov/stdspdf.htm

Tax Deductions and Credits for Barrier Removal

www.ada.gov/taxincent.htm

Acknowledgements

Many of the illustrations are from the U.S. Department of Justice and the U.S. Access Board or are based on illustrations produced by the U.S. Access Board and the U.S. Department of Justice.

Develop an Implementation Plan -

Although an implementation plan is not required, the Department of Justice recommends such a plan, specifying what barriers will be removed and when solutions will occur: "*...Such a plan...could serve as evidence of a good faith effort to comply...*" Prioritize items, make a timeline and develop a budget. Where the removal of barriers is not readily achievable, consider whether there are alternative methods for providing access that are readily achievable such as curbside takeout service at a restaurant with an accessible intercom system outside.

Make Changes -

Use the 2010 ADA Standards for Accessible Design. Note: Until March 15, 2012 the 1991 ADA Standards for Accessible Design may be used for readily achievable barrier removal. Check whether local and state building codes require greater accessibility when alterations are undertaken.

Follow Up -

Review the implementation plan each year to evaluate whether more access improvements have become readily achievable.

ADA Checklist for Readily Achievable Barrier Removal

Priority 1 – Approach & Entrance



Project _____

Building _____

Location _____

Date _____

Surveyors _____

Contact Information _____

An accessible route from site arrival points and an accessible entrance should be provided for everyone.



Institute for Human Centered Design
www.HumanCenteredDesign.org
November 2011



ADA National Network
Questions on the ADA 800-949-4232 voice/tty
www.ADAchecklist.org

This checklist was produced by the New England ADA Center, a project of the Institute for Human Centered Design and a member of the ADA National Network. This checklist was developed under a grant from the Department of Education, NIDRR grant number H133A060092-09A. However the contents do not necessarily represent the policy of the Department of Education, and you should not assume endorsement by the Federal Government.

Questions or comments on the checklist contact the New England ADA Center at 617-695-0085 voice/tty or ADAinfo@NewEnglandADA.org

For the full set of checklists, including the checklists for recreation facilities visit www.ADAchecklist.org.

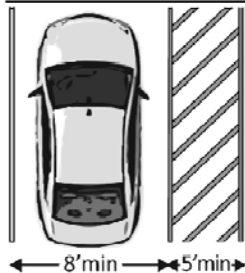
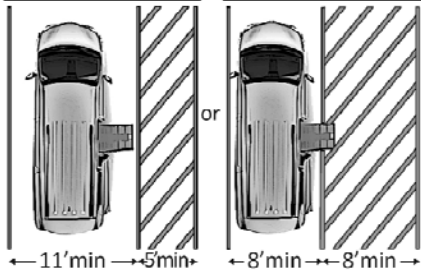
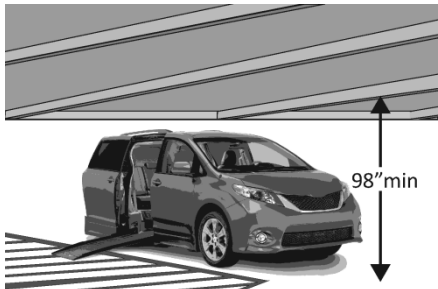
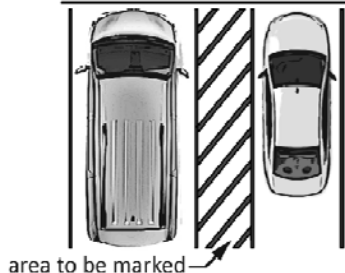

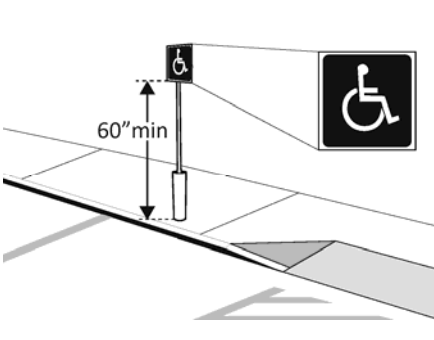


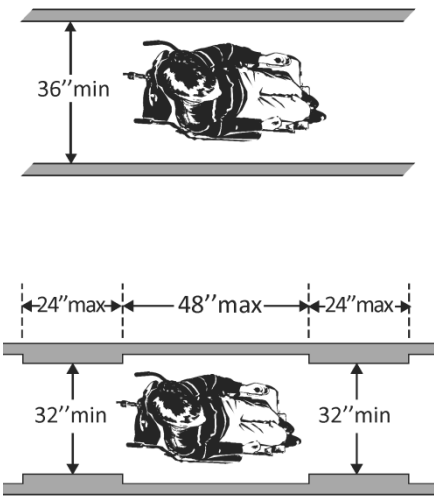
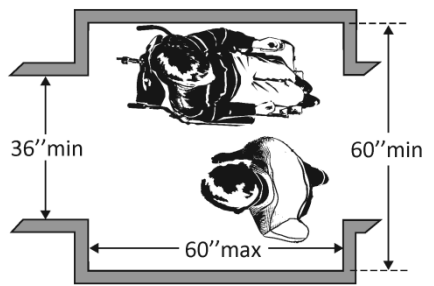
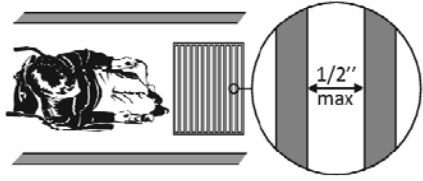
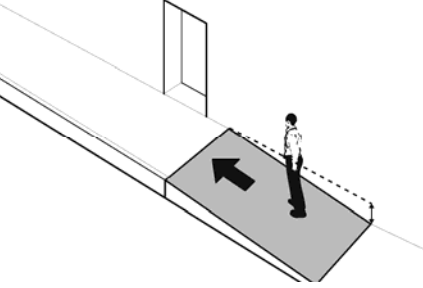
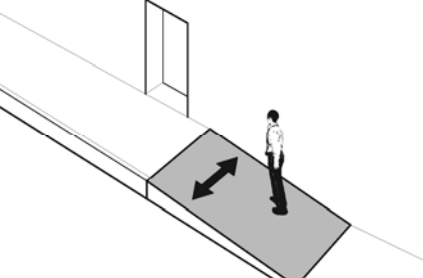
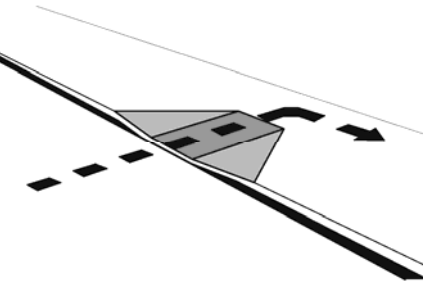
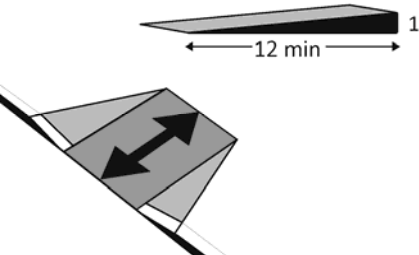
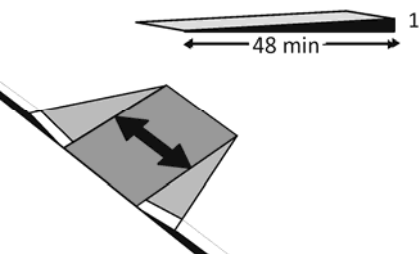
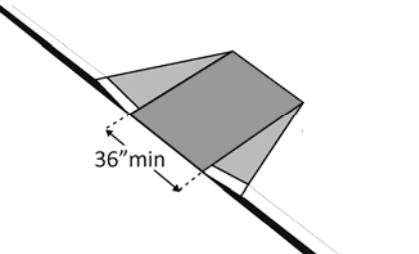
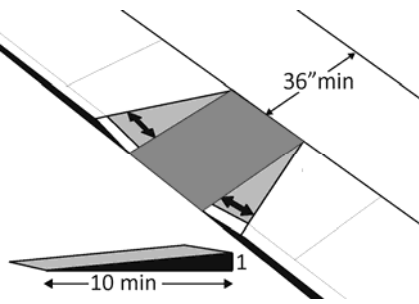
Priority 1 – Approach & Entrance		Comments	Possible Solutions												
<p>1.1 Is there at least one route from site arrival points (parking, passenger loading zones, public sidewalks and public transportation stops) that does not require the use of stairs?</p> <p><input type="checkbox"/> Yes <input type="checkbox"/> No</p> <p>If yes, location of route:</p>		Photo #:	<ul style="list-style-type: none"> • Add a ramp • Regrade to 1:20 maximum slope • Add a lift if site constraints prevent other solutions 												
<p>Parking (2010 Standards – 208 & 502) Note: Accessible parking spaces should be identified by size, access aisle and signage.</p>															
<p>1.2 If parking is provided for the public, are an adequate number of accessible spaces provided?</p> <p><input type="checkbox"/> Yes <input type="checkbox"/> No</p> <p>Total #:</p> <p>Accessible #:</p>	<table border="1"> <thead> <tr> <th>Total Spaces</th> <th>Accessible Spaces</th> </tr> </thead> <tbody> <tr> <td>1 - 25</td> <td>1</td> </tr> <tr> <td>26 - 50</td> <td>2</td> </tr> <tr> <td>51 - 75</td> <td>3</td> </tr> <tr> <td>76 - 100</td> <td>4</td> </tr> <tr> <td colspan="2">100+ see 2010 Standards 208.2</td> </tr> </tbody> </table>	Total Spaces	Accessible Spaces	1 - 25	1	26 - 50	2	51 - 75	3	76 - 100	4	100+ see 2010 Standards 208.2		Photo #:	<ul style="list-style-type: none"> • Reconfigure by repainting lines • •
Total Spaces	Accessible Spaces														
1 - 25	1														
26 - 50	2														
51 - 75	3														
76 - 100	4														
100+ see 2010 Standards 208.2															
<p>1.3 Of the accessible spaces, is at least one a van accessible space?*</p> <p><input type="checkbox"/> Yes <input type="checkbox"/> No</p>	<p>*For every 6 or fraction of 6 parking spaces required by the table above, at least 1 should be a van accessible space.</p>	Photo #:	<p>* If constructed before 3/15/2012, parking is compliant if at least 1 in every 8 accessible spaces is van accessible</p> <ul style="list-style-type: none"> • Reconfigure by repainting lines 												
<p>1.4 Are accessible spaces at least 8 feet wide with an access aisle at least 5 feet wide?</p> <p><input type="checkbox"/> Yes <input type="checkbox"/> No</p> <p>Measurement:</p>	 <p>The diagram shows a top-down view of a car in a parking space. To the right of the car is a shaded area representing an access aisle. Dimension lines indicate the car is 8 feet wide and the access aisle is 5 feet wide.</p>		<ul style="list-style-type: none"> • Reconfigure by repainting lines <p>Two spaces can share an access aisle (check state requirements; some states, such as Connecticut, require an access aisle for</p>												

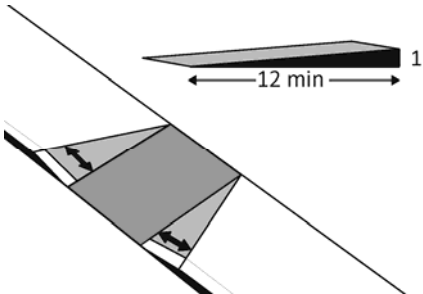
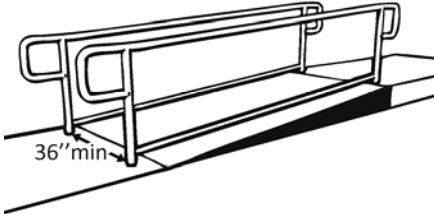

			Photo #:	each space)
<p>1.5 Is the van accessible space:</p> <p>At least 11 feet wide with an access aisle at least 5 feet wide? Or At least 8 feet wide with an access aisle at least 8 feet wide?</p>	<p><input type="checkbox"/> Yes <input type="checkbox"/> No</p> <p>Measurement:</p> <p><input type="checkbox"/> Yes <input type="checkbox"/> No</p> <p>Measurement:</p>		Photo #:	<ul style="list-style-type: none"> • Reconfigure to provide van-accessible space(s) • •
<p>1.6 Is at least 98 inches of vertical clearance provided for the van accessible space?</p>	<p><input type="checkbox"/> Yes <input type="checkbox"/> No</p> <p>Measurement:</p>		Photo #:	<ul style="list-style-type: none"> • Reconfigure to provide van-accessible space(s) • •
<p>1.7 Are the access aisles marked so as to discourage parking in them?</p>	<p><input type="checkbox"/> Yes <input type="checkbox"/> No</p>		Photo #:	<ul style="list-style-type: none"> • Mark access aisles • • <p>The marking method and color may be addressed by state/local requirements</p>
<p>1.8 Is the slope of the accessible parking spaces and access aisles no steeper than 1:48 in all directions?</p>	<p><input type="checkbox"/> Yes <input type="checkbox"/> No</p> <p>Measurement:</p>		Photo #:	<ul style="list-style-type: none"> • Regrade surface • •

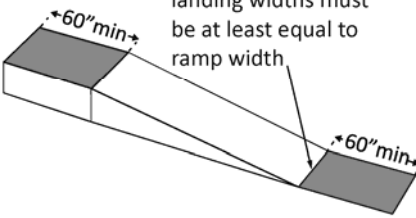
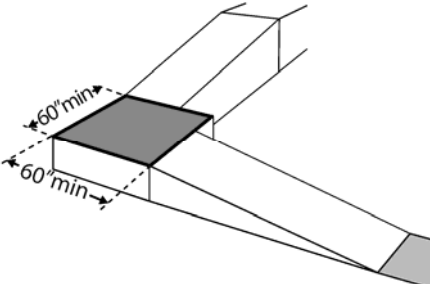
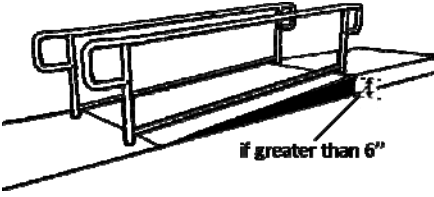
<p>1.9 Do the access aisles adjoin an accessible route?</p>	<p><input type="checkbox"/> Yes <input type="checkbox"/> No</p>		<p>Photo #:</p>	<ul style="list-style-type: none"> • Create accessible route • Relocate accessible space •
<p>1.10 Are accessible spaces Identified with a sign that includes the International Symbol of Accessibility?</p> <p>Is the bottom of the sign at least 60 inches above the ground?</p>	<p><input type="checkbox"/> Yes <input type="checkbox"/> No</p> <p><input type="checkbox"/> Yes <input type="checkbox"/> No</p> <p>Measurement:</p>		<p>Photo #:</p>	<ul style="list-style-type: none"> • Install signs • • <p>The International Symbol of Accessibility is not required on the ground by the 2010 Standards</p>
<p>1.11 Are there signs reading “van accessible” at van accessible spaces?</p>	<p><input type="checkbox"/> Yes <input type="checkbox"/> No</p>		<p>Photo #:</p>	<ul style="list-style-type: none"> • Install signs • •
<p>1.12 Of the total parking spaces, are the accessible spaces located on the closest accessible route to the accessible entrance(s)?</p>	<p><input type="checkbox"/> Yes <input type="checkbox"/> No</p>		<p>Photo #:</p>	<ul style="list-style-type: none"> • Reconfigure spaces • • <p>If parking lot serves multiple entrances, accessible parking should be dispersed</p>

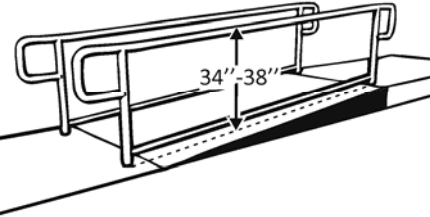
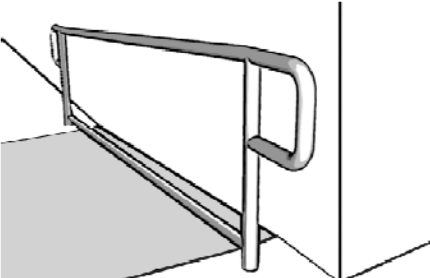
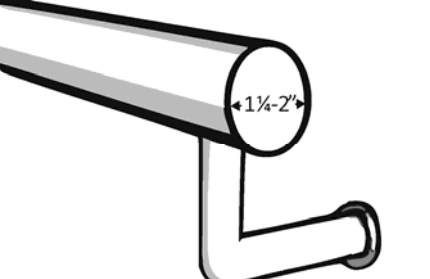
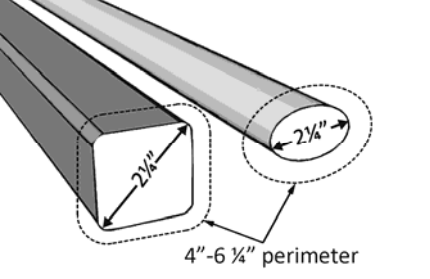
Exterior Accessible Route (2010 Standards – Ch.4)				
<p>1.13 Is the route stable, firm and slip-resistant?</p>	<p><input type="checkbox"/> Yes <input type="checkbox"/> No</p>		<p>Photo #:</p>	<ul style="list-style-type: none"> • Repair uneven paving • Fill small bumps and breaks with patches • Replace gravel with asphalt or other surface
<p>1.14 Is the route at least 36 inches wide?</p> <p>Note: The accessible route can narrow to 32 inches min. for a max. of 24 inches. These narrower portions of the route must be at least 48 inches from each other.</p>	<p><input type="checkbox"/> Yes <input type="checkbox"/> No</p> <p>Measurement:</p>	 <p>The diagram illustrates two scenarios for route width. The top scenario shows a wheelchair on a path that is at least 36 inches wide. The bottom scenario shows a wheelchair on a path that is at least 32 inches wide, with narrow sections of 24 inches maximum width. These narrow sections must be separated by a distance of at least 48 inches.</p>	<p>Photo #:</p>	<ul style="list-style-type: none"> • Change or move landscaping, furnishings or other items • Widen route •
<p>1.15 If the route is greater than 200 feet in length and no less than 60 inches wide, is there a passing space no less than 60 x 60 inches?</p>	<p><input type="checkbox"/> Yes <input type="checkbox"/> No</p> <p>Measurement:</p>	 <p>The diagram shows a passing space for two wheelchairs. The space is at least 36 inches high and 60 inches wide. The wheelchairs are shown facing each other, with a 60-inch maximum width for the passing space.</p>	<p>Photo #:</p>	<ul style="list-style-type: none"> • Widen route for passing space • •

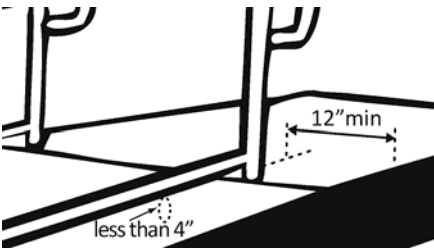
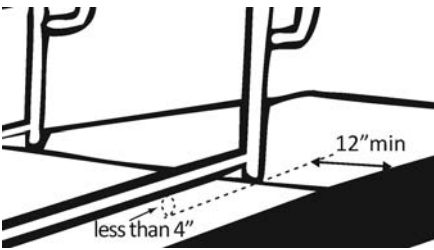
<p>1.16 If there are grates or openings on the route, are the openings no larger than ½ inches to the dominant direction of travel?</p> <p>Is the long dimension perpendicular to the dominant direction of travel?</p>	<p><input type="checkbox"/> Yes <input type="checkbox"/> No</p> <p>Measurement:</p> <p><input type="checkbox"/> Yes <input type="checkbox"/> No</p>		<p>Photo #:</p>	<ul style="list-style-type: none"> • Replace or move grate • •
<p>1.17 Is the running slope no steeper than 1:20, i.e. for every inch of height change there are at least 20 inches of route run?</p>	<p><input type="checkbox"/> Yes <input type="checkbox"/> No</p> <p>Measurement:</p>		<p>Photo #:</p>	<ul style="list-style-type: none"> • Regrade to 1:20 max. • If steeper than 1:20 and no steeper than 1:12, treat as a ramp and add other features such as edge protection and handrails •
<p>1.18 Is the cross slope no steeper than 1:48?</p>	<p><input type="checkbox"/> Yes <input type="checkbox"/> No</p> <p>Measurement:</p>		<p>Photo #:</p>	<ul style="list-style-type: none"> • Regrade to 1:48 max. • •
<p>Curb Ramps (2010 Standards – 406)</p>				
<p>1.19 If the accessible route crosses a curb, is there a curb ramp?</p>	<p><input type="checkbox"/> Yes <input type="checkbox"/> No</p>		<p>Photo #:</p>	<ul style="list-style-type: none"> • Install curb ramp • •




<p>1.20 Is the running slope of the curb ramp no steeper than 1:12, i.e. for every inch of height change there are at least 12 inches of curb ramp run?</p>	<p><input type="checkbox"/> Yes <input type="checkbox"/> No</p> <p>Measurement:</p>		<p>Photo #:</p>	<ul style="list-style-type: none"> • Regrade curb ramp • •
<p>1.21 Is the cross slope of the curb ramp, excluding flares, no steeper than 1:48?</p>	<p><input type="checkbox"/> Yes <input type="checkbox"/> No</p> <p>Measurement:</p>		<p>Photo #:</p>	<ul style="list-style-type: none"> • Regrade curb ramp • •
<p>1.22 Is the curb ramp, excluding flares, at least 36 inches wide?</p>	<p><input type="checkbox"/> Yes <input type="checkbox"/> No</p> <p>Measurement:</p>		<p>Photo #:</p>	<ul style="list-style-type: none"> • Widen curb ramp • •
<p>1.23 At the top of the curb ramp is there a level landing (slope no steeper than 1:48 in all directions) that is at least 36 inches long and at least as wide as the curb ramp?</p> <p>If there are curb ramp flares, are the slopes of the flares no steeper than 1:10, i.e. for every inch of height change there are</p>	<p><input type="checkbox"/> Yes <input type="checkbox"/> No</p> <p>Measurement:</p> <p><input type="checkbox"/> Yes <input type="checkbox"/> No</p> <p>Measurement:</p>		<p>Photo #:</p>	<ul style="list-style-type: none"> • Reconfigure • Add ramp flares •

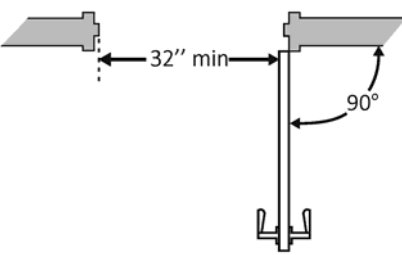
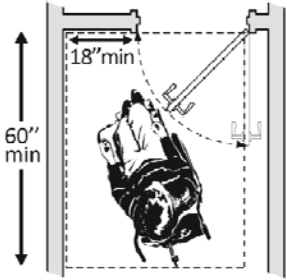
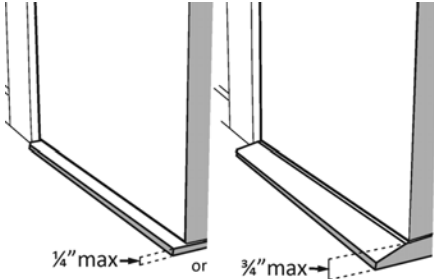
<p>at least 10 inches of flare run?</p>			<p>Photo #:</p>	
<p>1.24 If the landing at the top is less than 36 inches long, are there curb ramp flares?</p> <p>Are the slopes of the flares no greater than 1:12, i.e. for every inch of height change there are at least 12 inches of flare run?</p>	<p><input type="checkbox"/> Yes <input type="checkbox"/> No</p> <p><input type="checkbox"/> Yes <input type="checkbox"/> No</p> <p>Measurement:</p>		<p>Photo #:</p>	<ul style="list-style-type: none"> • Add ramp flares • Regrade flares •
<p>Ramps (2010 Standards – 405 & 505) Note: If any portion of the accessible route is steeper than 1:20, it should be treated as a ramp.</p>				
<p>1.25 If there is a ramp (other than curb ramps), is it at least 36 inches wide? If there are handrails, measure between the handrails.</p>	<p><input type="checkbox"/> Yes <input type="checkbox"/> No</p> <p>Measurement:</p>		<p>Photo #:</p>	<ul style="list-style-type: none"> • Alter ramp • •
<p>1.26 Is the surface stable, firm and slip resistant?</p>	<p><input type="checkbox"/> Yes <input type="checkbox"/> No</p>		<p>Photo #:</p>	<ul style="list-style-type: none"> • Resurface ramp • •
<p>1.27 For each section of the ramp, is the running slope no greater than 1:12, i.e. for every inch of height change there are at least 12 inches of ramp run?</p> <p>Note: Rises no greater than 3 inches with a slope no steeper than</p>	<p><input type="checkbox"/> Yes <input type="checkbox"/> No</p> <p>Measurement:</p>		<p>Photo #:</p>	<ul style="list-style-type: none"> • Alter or relocate ramp • Lengthen ramp to decrease slope •


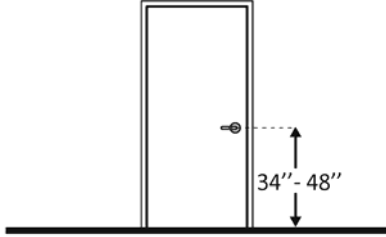
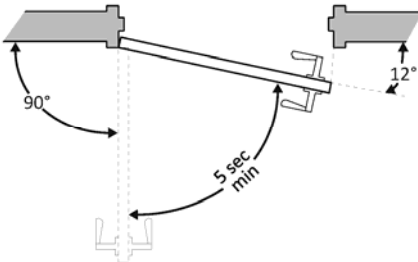
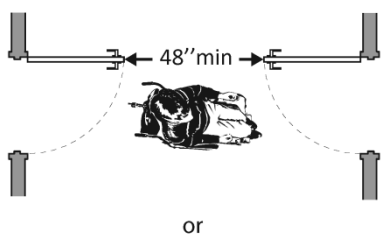
<p>1:8 and rises no greater than 6 inches with a slope no steeper than 1:10 are permitted when such slopes are necessary due to space limitations.</p>			<p>Photo #:</p>	
<p>1.28 Is there a level landing that is at least 60 inches long and at least as wide as the ramp:</p> <p>At the top of the ramp?</p> <p>At the bottom of the ramp?</p>	<p><input type="checkbox"/> Yes <input type="checkbox"/> No</p> <p>Measurement:</p> <p><input type="checkbox"/> Yes <input type="checkbox"/> No</p> <p>Measurement:</p>		<p>Photo #:</p>	<ul style="list-style-type: none"> • Alter ramp • •
<p>1.29 Is there a level landing where the ramp changes direction that is at least 60 x 60 inches?</p>	<p><input type="checkbox"/> Yes <input type="checkbox"/> No</p> <p>Measurement:</p>		<p>Photo #:</p>	<ul style="list-style-type: none"> • Alter ramp • •
<p>1.30 If the ramp has a rise higher than 6 inches, are there handrails on both sides?</p>	<p><input type="checkbox"/> Yes <input type="checkbox"/> No</p> <p>Measurement:</p>		<p>Photo #:</p>	<ul style="list-style-type: none"> • Add handrails • • <p>Curb ramps are not required to have handrails</p>

<p>1.31 Is the top of the handrail gripping surface no less than 34 inches and no greater than 38 inches above the ramp surface?</p>	<p><input type="checkbox"/> Yes <input type="checkbox"/> No</p> <p>Measurement:</p>		<p>Photo #:</p>	<ul style="list-style-type: none"> • Reconfigure or replace handrails • •
<p>1.32 Is the handrail gripping surface continuous and not obstructed along the top or sides?</p> <p>Is the bottom of the handrail gripping surface obstructed for no more than 20 percent of its length?</p>	<p><input type="checkbox"/> Yes <input type="checkbox"/> No</p> <p><input type="checkbox"/> Yes <input type="checkbox"/> No</p> <p>Measurement:</p>		<p>Photo #:</p>	<ul style="list-style-type: none"> • Reconfigure or replace handrails • •
<p>1.33 If the handrail gripping surface is circular, is it no less than 1 ¼ inches and no greater than 2 inches in diameter?</p>	<p><input type="checkbox"/> Yes <input type="checkbox"/> No</p> <p>Measurement:</p>		<p>Photo #:</p>	<ul style="list-style-type: none"> • Replace handrails • •
<p>1.34 If the handrail gripping surface is non-circular, is it no less than 4 inches and no greater than 6 ½ inches in perimeter and no more than 2 ¼ inches in cross section?</p>	<p><input type="checkbox"/> Yes <input type="checkbox"/> No</p> <p>Measurement:</p>		<p>Photo #:</p>	<ul style="list-style-type: none"> • Replace handrails • •

<p>1.35 Does the handrail:</p> <p>Extend at least 12 inches horizontally beyond the top and bottom of the ramp?</p> <p>Return to a wall, guard, or landing surface?</p>	<p><input type="checkbox"/> Yes <input type="checkbox"/> No</p> <p>Measurement:</p> <p><input type="checkbox"/> Yes <input type="checkbox"/> No</p>		<p>Photo #:</p>	<ul style="list-style-type: none"> • Add extensions • Reconfigure handrails •
<p>1.36 To prevent wheelchair casters and crutch tips from falling off:</p> <p>Does the surface of the ramp extend at least 12 inches beyond the inside face of the handrail?</p> <p>Or</p> <p>Is there a curb or barrier that prevents the passage of a 4-inch diameter sphere?</p>	<p><input type="checkbox"/> Yes <input type="checkbox"/> No</p> <p>Measurement:</p> <p><input type="checkbox"/> Yes <input type="checkbox"/> No</p> <p>Measurement:</p>		<p>Photo #:</p>	<ul style="list-style-type: none"> • Add curb • Add barrier • Extend ramp width •
<p>Entrance (2010 Standards – 404)</p>				
<p>1.37 Is the main entrance accessible?</p>	<p><input type="checkbox"/> Yes <input type="checkbox"/> No</p>		<p>Photo #:</p>	<ul style="list-style-type: none"> • Redesign to make it accessible • •

<p>1.38 If the main entrance is not accessible, is there an alternative accessible entrance?</p> <p>Can the alternative accessible entrance be used independently and during the same hours as the main entrance?</p>	<p><input type="checkbox"/> Yes <input type="checkbox"/> No</p> <p><input type="checkbox"/> Yes <input type="checkbox"/> No</p>		<p>Photo #:</p>	<ul style="list-style-type: none"> • Designate an entrance and make it accessible • Ensure that accessible entrance can be used independently and during the same hours as the main entrance •
<p>1.39 Do all inaccessible entrances have signs indicating the location of the nearest accessible entrance?</p>	<p><input type="checkbox"/> Yes <input type="checkbox"/> No</p>		<p>Photo #:</p>	<ul style="list-style-type: none"> • Install signs • Install signs on route before people get to inaccessible entrances so that people do not have to turn around and retrace route •
<p>1.40 If not all entrances are accessible, is there a sign at the accessible entrance with the International Symbol of Accessibility?</p>	<p><input type="checkbox"/> Yes <input type="checkbox"/> No</p>		<p>Photo #:</p>	<ul style="list-style-type: none"> • Install sign • •

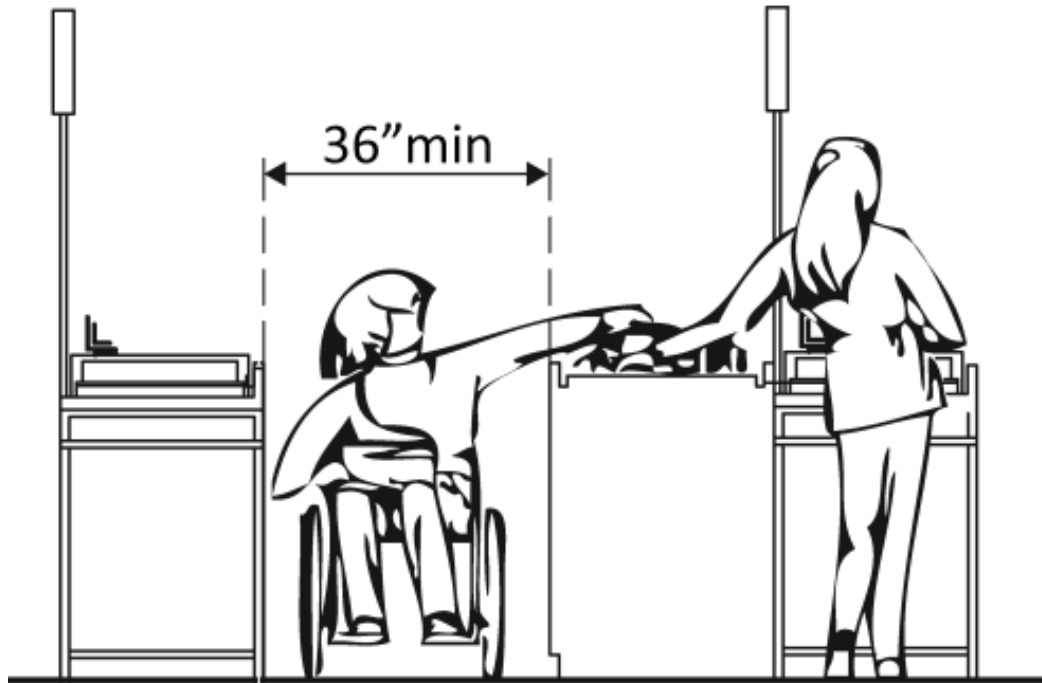
<p>1.41 Is the clear opening width of the accessible entrance door at least 32 inches, between the face of the door and the stop, when the door is open 90 degrees?</p>	<p><input type="checkbox"/> Yes <input type="checkbox"/> No</p> <p>Measurement:</p>		<p>Photo #:</p>	<ul style="list-style-type: none"> • Alter door • Install offset hinges •
<p>1.42 If there is a front approach to the pull side of the door, is there at least 18 inches of maneuvering clearance beyond the latch side plus at least 60 inches clear depth?</p> <p>On both sides of the door, is the ground or floor surface of the maneuvering clearance level (no steeper than 1:48)?</p>	<p><input type="checkbox"/> Yes <input type="checkbox"/> No</p> <p>Measurement:</p> <p><input type="checkbox"/> Yes <input type="checkbox"/> No</p> <p>Measurement:</p>		<p>Photo #:</p>	<p>See 2010 Standards 404.2.4 for maneuvering clearance requirements on the push side of the door and side approaches to the pull side of the door</p> <ul style="list-style-type: none"> • Remove obstructions • Reconfigure walls • Add automatic door opener
<p>1.43 Is the door threshold edge no more than ¼ inch high?</p> <p>Or</p> <p>No more than ¾ inch high if slope is beveled no steeper than 1:2?</p> <p>Note: The first ¼ inch of the threshold may be vertical; the rest must be beveled.</p>	<p><input type="checkbox"/> Yes <input type="checkbox"/> No</p> <p>Measurement:</p> <p><input type="checkbox"/> Yes <input type="checkbox"/> No</p> <p>Measurement:</p>		<p>Photo #:</p>	<ul style="list-style-type: none"> • Remove or replace threshold • •

<p>1.44 Is the door equipped with hardware, including locks, that is operable with one hand and does not require tight grasping, pinching, or twisting of the wrist?</p>	<p><input type="checkbox"/> Yes <input type="checkbox"/> No</p>		<p>Photo #:</p>	<ul style="list-style-type: none"> • Replace inaccessible knob with lever, loop or push hardware • Add automatic door opener •
<p>1.45 Are the operable parts of the door hardware no less than 34 inches and no greater than 48 inches above the floor or ground surface?</p>	<p><input type="checkbox"/> Yes <input type="checkbox"/> No</p> <p>Measurement:</p>		<p>Photo #:</p>	<ul style="list-style-type: none"> • Change hardware height • •
<p>1.46 If the door has a closer, does it take at least 5 seconds to close from an open position of 90 degrees to a position of 12 degrees from the latch?</p>	<p><input type="checkbox"/> Yes <input type="checkbox"/> No</p> <p>Measurement:</p>		<p>Photo #:</p>	<ul style="list-style-type: none"> • Adjust closer • •
<p>1.47 If there are two doors in a series, e.g. vestibule, is the distance between the doors at least 48 inches plus the width of the doors when swinging into the space?</p>	<p><input type="checkbox"/> Yes <input type="checkbox"/> No</p> <p>Measurement:</p>		<p>Photo #:</p>	<ul style="list-style-type: none"> • Remove inner door • Change door swing •

		<p style="text-align: center;">48" min</p> <p style="text-align: center;">or</p> <p style="text-align: center;">48" min</p>	<p>Photo #:</p>	
<p>1.48 If provided at the building entrance, are carpets or mats no higher than ½ inch thick?</p>	<p><input type="checkbox"/> Yes <input type="checkbox"/> No</p> <p>Measurement:</p>	<p style="text-align: center;">½" max</p>	<p>Photo #:</p>	<ul style="list-style-type: none"> • Replace or remove mats • •
<p>1.49 Are edges of carpets or mats securely attached to minimize tripping hazards?</p>	<p><input type="checkbox"/> Yes <input type="checkbox"/> No</p>		<p>Photo #:</p>	<ul style="list-style-type: none"> • Secure carpeting or mats at edges • •

ADA Checklist for Readily Achievable Barrier Removal

Priority 2 – Access to Goods & Services



Project _____

Building _____

Location _____

Date _____

Surveyors _____

Contact Information _____

The layout of the building should allow people with disabilities to obtain goods and services and to participate in activities without assistance.



Institute for Human Centered Design
www.HumanCenteredDesign.org
November 2011



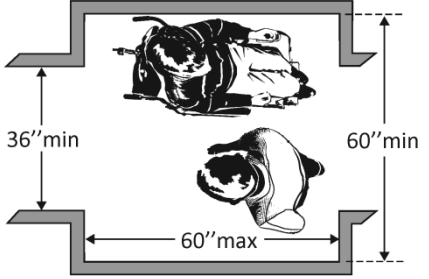
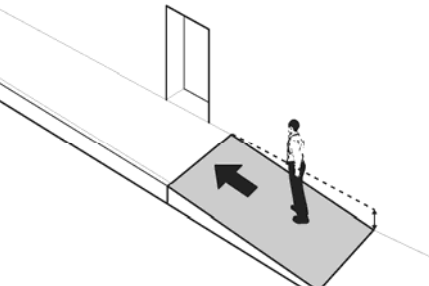
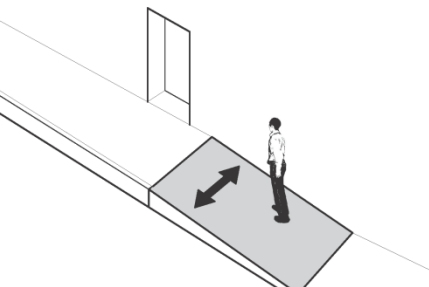

ADA National Network
Questions on the ADA 800-949-4232 voice/tty
www.ADAchecklist.org

This checklist was produced by the New England ADA Center, a project of the Institute for Human Centered Design and a member of the ADA National Network. This checklist was developed under a grant from the Department of Education, NIDRR grant number H133A060092-09A. However the contents do not necessarily represent the policy of the Department of Education, and you should not assume endorsement by the Federal Government.

Questions or comments on the checklist contact the New England ADA Center at 617-695-0085 voice/tty or ADAinfo@NewEnglandADA.org

For the full set of checklists, including the checklists for recreation facilities visit www.ADAchecklist.org.

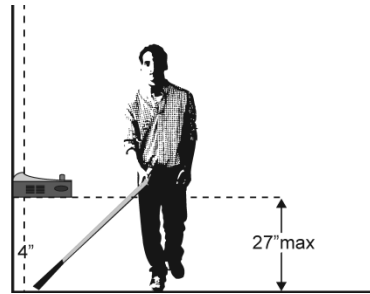
Priority 2 – Access to Goods & Services		Comments	Possible Solutions
<p>2.1 Does the accessible entrance provide direct access to the main floor, lobby and elevator?</p> <p><input type="checkbox"/> Yes <input type="checkbox"/> No</p>		Photo #:	<ul style="list-style-type: none"> • Create accessible route • •
<p>Interior Accessible Route (2010 Standards – Ch.4)</p>			
<p>2.2 Are all public spaces on at least one accessible route?</p> <p><input type="checkbox"/> Yes <input type="checkbox"/> No</p>		Photo #:	<ul style="list-style-type: none"> • Create accessible route • •
<p>2.3 Is the route stable, firm and slip-resistant?</p> <p><input type="checkbox"/> Yes <input type="checkbox"/> No</p>		Photo #:	<ul style="list-style-type: none"> • Repair uneven surfaces • •
<p>2.4 Is the route at least 36 inches wide?</p> <p>Note: The accessible route can narrow to 32 inches min. for a max. of 24 inches. These narrower portions of the route must be at least 48 inches from each other.</p>	<p>Measurement:</p>	Photo #:	<ul style="list-style-type: none"> • Widen route • •

<p>2.5 If the route is greater than 200 feet in length and no less than 36 inches wide, is there a passing space no less than 60 x 60 inches?</p>	<p><input type="checkbox"/> Yes <input type="checkbox"/> No</p> <p>Measurement:</p>		<p>Photo #:</p>	<ul style="list-style-type: none"> • Widen route for passing space • •
<p>2.6 Is the running slope no steeper than 1:20, i.e. for every inch of height change there are at least 20 inches of route run?</p>	<p><input type="checkbox"/> Yes <input type="checkbox"/> No</p> <p>Measurement:</p>		<p>Photo #:</p>	<ul style="list-style-type: none"> • Regrade • If steeper than 1:20 and no steeper than 1:12, treat as ramp and add other features such as edge protection and handrails •
<p>2.7 Is the cross slope no steeper than 1:48?</p>	<p><input type="checkbox"/> Yes <input type="checkbox"/> No</p> <p>Measurement:</p>		<p>Photo #:</p>	<ul style="list-style-type: none"> • Regrade • •
<p>2.8 Do all objects on circulation paths through public areas, e.g. fire extinguishers, drinking fountains, signs, etc., protrude no more than 4 inches into the path? Or If an object protrudes more than 4 inches, is the bottom leading edge at 27 inches or lower above the floor?</p>	<p><input type="checkbox"/> Yes <input type="checkbox"/> No</p> <p>Measurement:</p> <p><input type="checkbox"/> Yes <input type="checkbox"/> No</p> <p>Measurement:</p>	 <p>Or</p>	<p>Photo #:</p>	<ul style="list-style-type: none"> • Remove object • Add tactile warning such as permanent planter or partial walls •

Or
Is the bottom leading edge at 80 inches or higher above the floor?

Yes No

Measurement:



Or

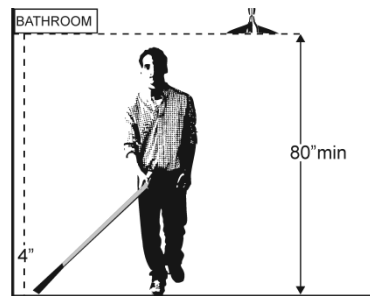


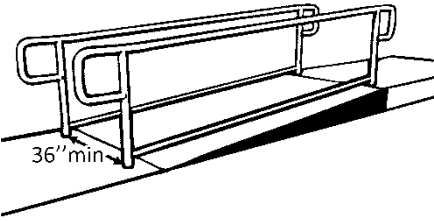
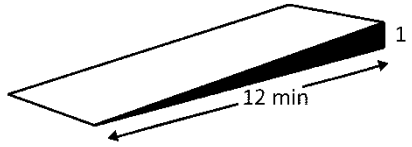
Photo #:

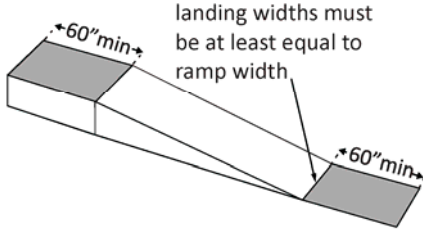
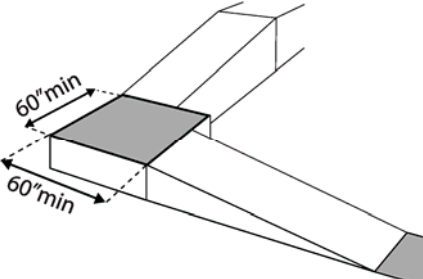
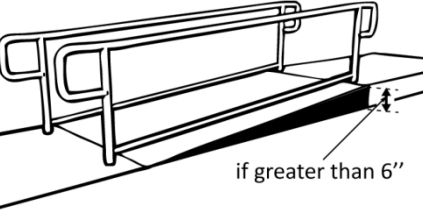
2.9 Are there elevators or platform lifts to all public stories?*

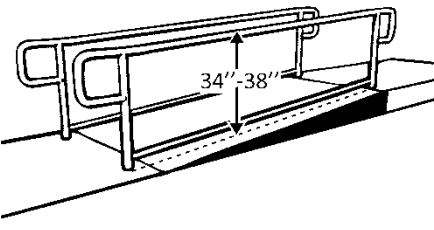
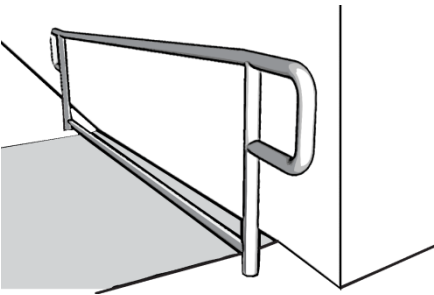
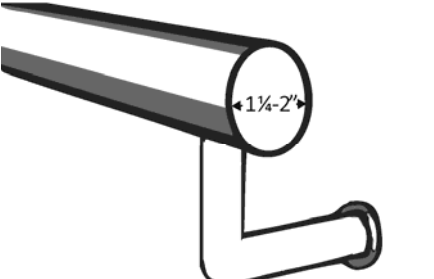
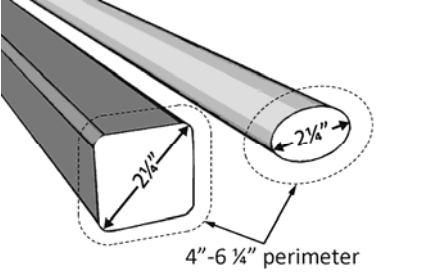
Yes No

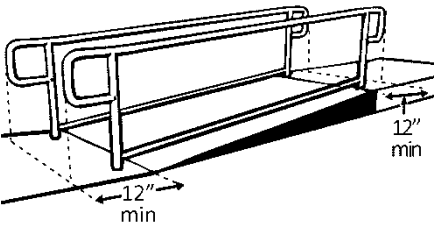
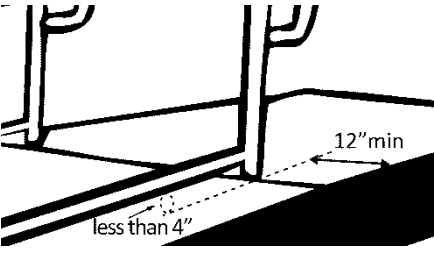
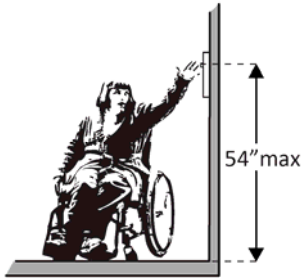
*Vertical access is not required in new construction or alterations if a facility is less than three stories or has less than 3,000 square feet per story, unless a facility is a shopping center, shopping mall, professional office of a health care provider, transportation terminal, state facility or government facility

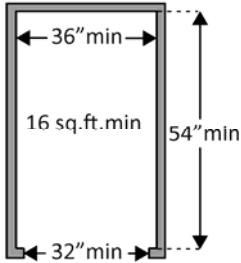
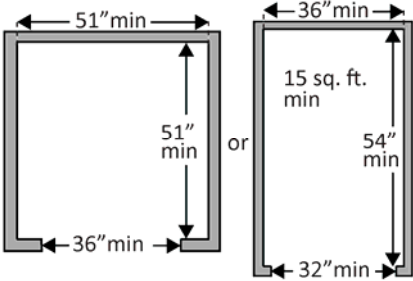
• Install if necessary

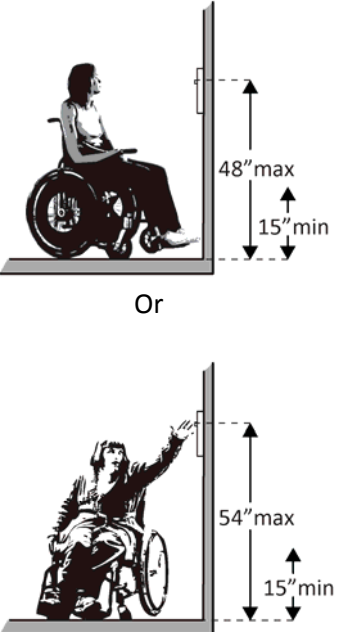

				<ul style="list-style-type: none"> • Offer goods and services on an accessible story •
Ramps (2010 Standards 404 & 505)				
<p>2.10 If there is a ramp, is it at least 36 inches wide? If there are handrails, measure between the handrails.</p>	<input type="checkbox"/> Yes <input type="checkbox"/> No Measurement:		Photo #:	<ul style="list-style-type: none"> • Alter ramp • •
<p>2.11 Is the surface stable, firm and slip resistant?</p>	<input type="checkbox"/> Yes <input type="checkbox"/> No		Photo #:	<ul style="list-style-type: none"> • Change surface • •
<p>2.12 For each section of the ramp, is the running slope no greater than 1:12, i.e. for every inch of height change there are at least 12 inches of ramp run?</p> <p>Note: Rises no greater than 3 inches with a slope no steeper than 1:8 and rises no greater than 6 inches with a slope no steeper than 1:10 are permitted when due to space limitations.</p>	<input type="checkbox"/> Yes <input type="checkbox"/> No Measurement:		Photo #:	<ul style="list-style-type: none"> • Lengthen ramp to decrease slope • Reconfigure ramp to include switchbacks • Relocate ramp •

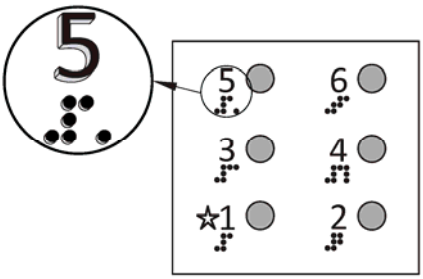
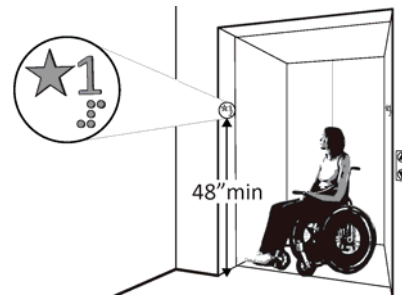
<p>2.13 Is there a level landing that is at least 60 inches long and at least as wide as the ramp:</p> <p>At the top of the ramp?</p> <p>At the bottom of the ramp?</p>	<p><input type="checkbox"/> Yes <input type="checkbox"/> No</p> <p>Measurement:</p> <p><input type="checkbox"/> Yes <input type="checkbox"/> No</p> <p>Measurement:</p>		<p>Photo #:</p>	<ul style="list-style-type: none"> • Alter ramp • Relocate ramp •
<p>2.14 Is there a level landing where the ramp changes direction that is at least 60 x 60 inches?</p>	<p><input type="checkbox"/> Yes <input type="checkbox"/> No</p> <p>Measurement:</p>		<p>Photo #:</p>	<ul style="list-style-type: none"> • Increase landing size • •
<p>2.15 If the ramp has a rise higher than 6 inches are there handrails on both sides?</p>	<p><input type="checkbox"/> Yes <input type="checkbox"/> No</p> <p>Measurement:</p>		<p>Photo #:</p>	<ul style="list-style-type: none"> • Add handrails • •

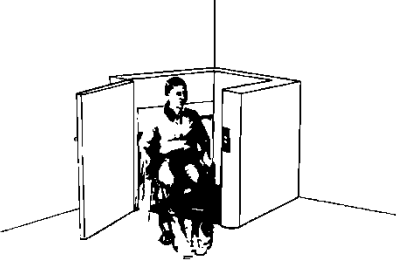
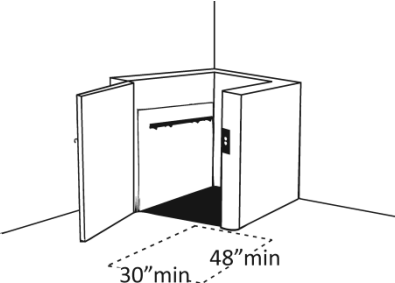
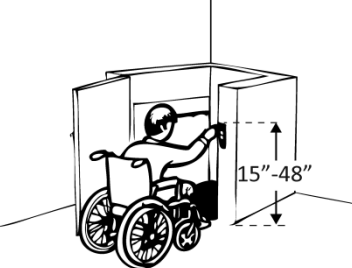
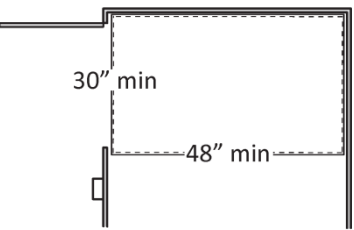
<p>2.16 Is the top of the handrail gripping surface no less than 34 inches and no greater than 38 inches above the ramp surface?</p>	<p><input type="checkbox"/> Yes <input type="checkbox"/> No</p> <p>Measurement:</p>		<p>Photo #:</p>	<ul style="list-style-type: none"> • Adjust handrail height • •
<p>2.17 Is the handrail gripping surface continuous and not obstructed along the top or sides?</p> <p>If there are obstructions, is the bottom of the handrail gripping surface obstructed by no more than 20%?</p>	<p><input type="checkbox"/> Yes <input type="checkbox"/> No</p> <p><input type="checkbox"/> Yes <input type="checkbox"/> No</p> <p>Measurement:</p>		<p>Photo #:</p>	<ul style="list-style-type: none"> • Regrade to 1:20 max • If steeper than 1:20 and no steeper than 1:12, treat as a ramp and add other features such as edge protection and handrails •
<p>2.18 If the handrail gripping surface is circular, is it no less than 1 ¼ inches and no greater than 2 inches in diameter?</p>	<p><input type="checkbox"/> Yes <input type="checkbox"/> No</p> <p>Measurement:</p>		<p>Photo #:</p>	<ul style="list-style-type: none"> • Alter handrails • •
<p>2.19 If the handrail gripping surface is non-circular, is it no less than 4 inches and no greater than 6 ½ inches in perimeter and no more than 2 ¼ inches in cross section?</p>	<p><input type="checkbox"/> Yes <input type="checkbox"/> No</p> <p>Measurement:</p>		<p>Photo #:</p>	<ul style="list-style-type: none"> • Alter handrails • •

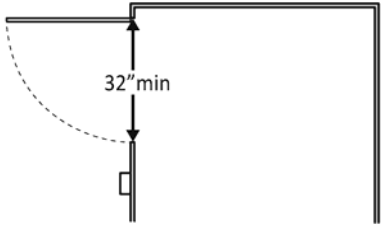
<p>2.20 Does the handrail:</p> <p>Extend at least 12 inches beyond the top and bottom of the ramp?</p> <p>Return to a wall, guard, or landing surface?</p>	<p><input type="checkbox"/> Yes <input type="checkbox"/> No</p> <p>Measurement:</p> <p><input type="checkbox"/> Yes <input type="checkbox"/> No</p>		<p>Photo #:</p>	<ul style="list-style-type: none"> • Alter handrails • • <p>If a 12" extension would be hazardous (in circulation path), it is not required</p>
<p>2.21 To prevent wheelchair casters and crutch tips from falling off:</p> <p>Does the surface of the ramp extend at least 12 inches beyond the inside face of the handrail?</p> <p>Or</p> <p>Is there a curb or barrier that prevents the passage of a 4-inch diameter sphere?</p>	<p><input type="checkbox"/> Yes <input type="checkbox"/> No</p> <p>Measurement:</p> <p><input type="checkbox"/> Yes <input type="checkbox"/> No</p> <p>Measurement:</p>		<p>Photo #:</p>	<ul style="list-style-type: none"> • Add curb • Add barrier • Extend ramp width • •
<p>Elevators – Full Size & LULA (limited use, limited application) (2010 Standards – 407 & 408) Note: LULA elevators are often used in alterations.</p>				
<p>2.22 If there is a full size or LULA elevator, are the call buttons no higher than 54 inches above the floor?</p>	<p><input type="checkbox"/> Yes <input type="checkbox"/> No</p> <p>Measurement:</p>		<p>Photo #:</p>	<ul style="list-style-type: none"> • Change call button height • •
<p>2.23 If there is a full size or LULA elevator, does the sliding door reopen automatically when obstructed by an object or person?*</p>	<p><input type="checkbox"/> Yes <input type="checkbox"/> No</p>			<p>* If constructed before 3/15/2012 and manually operated, the door is not required to reopen automatically</p>

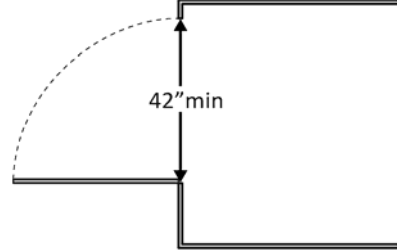
			<p>Photo #:</p>	<ul style="list-style-type: none"> • Install opener •
<p>2.24 If there is a LULA elevator with a swinging door:</p> <p>Is the door power- operated? <input type="checkbox"/> Yes <input type="checkbox"/> No</p> <p>Does the door remain open for at least 20 seconds when activated? <input type="checkbox"/> Yes <input type="checkbox"/> No</p> <p>Time:</p>			<p>Photo #:</p>	<ul style="list-style-type: none"> • Add power operated door • Adjust opening time •
<p>2.25 If there is a full size elevator:</p> <p>Is the interior at least 54 inches deep by at least 36 inches wide with at least 16 sq. ft. of clear floor area? <input type="checkbox"/> Yes <input type="checkbox"/> No</p> <p>Measurement:</p> <p>Is the door opening width at least 32 inches? <input type="checkbox"/> Yes <input type="checkbox"/> No</p> <p>Measurement:</p>			<p>Photo #:</p>	<ul style="list-style-type: none"> • Replace elevator • •
<p>2.26 If there is a LULA elevator, is the interior:</p> <p>At least 51 x 51 inches with a door opening width of at least 36 inches? <input type="checkbox"/> Yes <input type="checkbox"/> No</p> <p>Measurement:</p> <p>Or</p> <p>At least 54 inches deep by at least 36 inches wide with at least 15 sq. ft. of clear floor <input type="checkbox"/> Yes <input type="checkbox"/> No</p> <p>Measurement:</p>			<p>Photo #:</p>	<ul style="list-style-type: none"> • Replace elevator • •

<p>area and a door opening width of at least 32 inches?</p>			<p>Photo #:</p>	
<p>2.27 If there is a full size or LULA elevator, are the in-car controls:</p> <p>No less than 15 inches and no greater 48 inches above the floor? Or Up to 54 inches above the floor for a parallel approach?</p>	<p><input type="checkbox"/> Yes <input type="checkbox"/> No Measurement:</p> <p><input type="checkbox"/> Yes <input type="checkbox"/> No Measurement:</p>		<p>Photo #:</p>	<ul style="list-style-type: none"> • Change control height • •
<p>2.28 If there is a LULA elevator, are the in-car controls centered on a side wall?</p>	<p><input type="checkbox"/> Yes <input type="checkbox"/> No Measurement:</p>		<p>Photo #:</p>	<ul style="list-style-type: none"> • Reconfigure controls • •

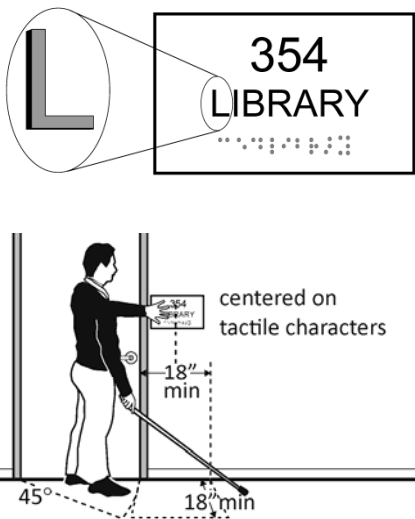
<p>2.29 If there is a full size or LULA elevator:</p> <p>Are the car control buttons designated with raised characters?</p> <p>Are the car control buttons designated with Braille?</p>	<p><input type="checkbox"/> Yes <input type="checkbox"/> No</p> <p><input type="checkbox"/> Yes <input type="checkbox"/> No</p>		<p>Photo #:</p>	<ul style="list-style-type: none"> • Add raised characters • Add Braille •
<p>2.30 If there is a full size or LULA elevator, are there audible signals which sound as the car passes or is about to stop at a floor?</p>	<p><input type="checkbox"/> Yes <input type="checkbox"/> No</p>		<p>Photo #:</p>	<ul style="list-style-type: none"> • Install audible signals • •
<p>2.31 If there is a full size or LULA elevator:</p> <p>Is there a sign on both door jambs at every floor identifying the floor?</p> <p>Is there a tactile star on both jambs at the main entry level?</p> <p>Do text characters contrast with their backgrounds?</p> <p>Are text characters raised?</p> <p>Is there Braille?</p> <p>Is the sign mounted between 48 inches to the baseline of the lowest character and 60 inches to the baseline of the highest character above the floor?*</p>	<p><input type="checkbox"/> Yes <input type="checkbox"/> No</p> <p><input type="checkbox"/> Yes <input type="checkbox"/> No</p> <p><input type="checkbox"/> Yes <input type="checkbox"/> No</p> <p><input type="checkbox"/> Yes <input type="checkbox"/> No</p> <p><input type="checkbox"/> Yes <input type="checkbox"/> No</p> <p><input type="checkbox"/> Yes <input type="checkbox"/> No</p> <p>Measurement:</p>		<p>Photo #:</p>	<ul style="list-style-type: none"> • Install signs • Change sign height • • <p>* If constructed before 3/15/2012 and mounted no higher than 60 inches to the centerline of the sign, relocation is not required</p>

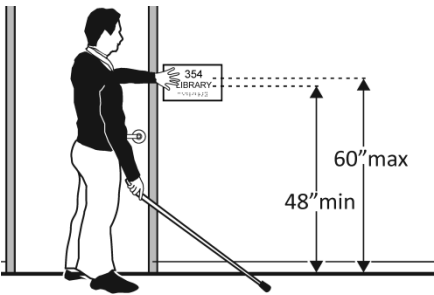
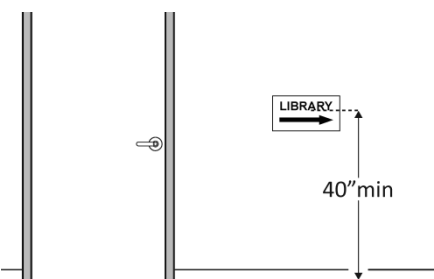
Platform Lifts (2010 Standards – 410)				
<p>2.32 If a lift is provided, can it be used without assistance from others?</p>	<p><input type="checkbox"/> Yes <input type="checkbox"/> No</p>		<p>Photo #:</p>	<ul style="list-style-type: none"> • Reconfigure so independently operable • •
<p>2.33 Is there a clear floor space at least 30 inches wide by at least 48 inches long for a person using a wheelchair to approach and reach the controls to use the lift?</p>	<p><input type="checkbox"/> Yes <input type="checkbox"/> No</p> <p>Measurement:</p>		<p>Photo #:</p>	<ul style="list-style-type: none"> • Remove obstructions • •
<p>2.34 Are the lift controls no less than 15 inches and no greater than 48 inches above the floor?</p>	<p><input type="checkbox"/> Yes <input type="checkbox"/> No</p> <p>Measurement:</p>		<p>Photo #:</p>	<ul style="list-style-type: none"> • Change control height • •
<p>2.35 Is there a clear floor space at least 30 inches wide by at least 48 inches long inside the lift?</p>	<p><input type="checkbox"/> Yes <input type="checkbox"/> No</p> <p>Measurement:</p>		<p>Photo #:</p>	<ul style="list-style-type: none"> • Replace lift • •

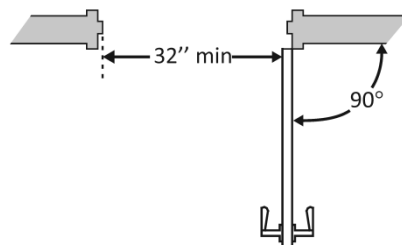
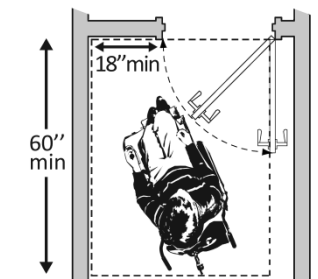
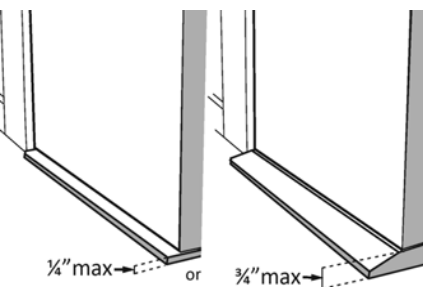
<p>2.36 If there is an end door, is the clear opening width at least 32 inches?</p>	<p><input type="checkbox"/> Yes <input type="checkbox"/> No</p> <p>Measurement:</p>		<p>Photo #:</p>	<ul style="list-style-type: none"> • Alter door width • •
--	---	--	-----------------	--

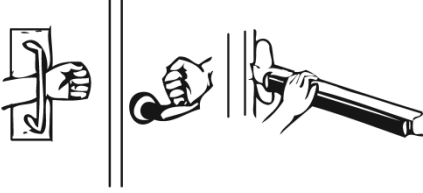
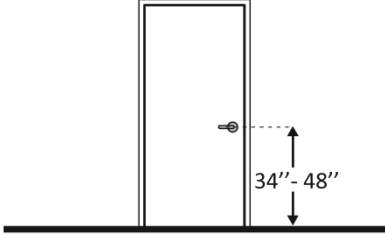
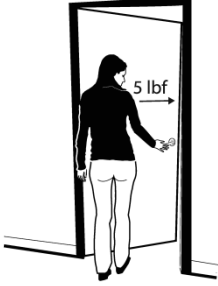
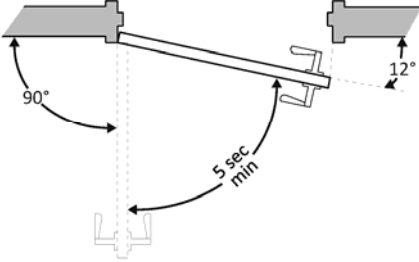
<p>2.37 If there is a side door, is the clear opening width at least 42 inches?</p>	<p><input type="checkbox"/> Yes <input type="checkbox"/> No</p> <p>Measurement:</p>		<p>Photo #:</p>	<ul style="list-style-type: none"> • Alter door width • •
--	---	--	-----------------	--

Signs (2010 Standards – 703) Note: “Tactile characters” are read using touch, i.e. raised characters and Braille.

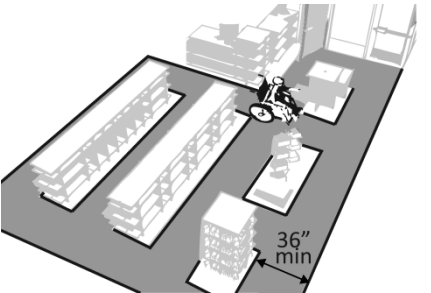

<p>2.38 If there are signs designating permanent rooms and spaces not likely to change over time, e.g. room numbers and letters, room names, and exit signs:</p> <p>Do text characters contrast with their backgrounds? <input type="checkbox"/> Yes <input type="checkbox"/> No</p> <p>Are text characters raised? <input type="checkbox"/> Yes <input type="checkbox"/> No</p> <p>Is there Braille? <input type="checkbox"/> Yes <input type="checkbox"/> No</p> <p>Is the sign mounted: On the wall on the latch side of the door? <input type="checkbox"/> Yes <input type="checkbox"/> No</p>	<p><input type="checkbox"/> Yes <input type="checkbox"/> No</p> <p><input type="checkbox"/> Yes <input type="checkbox"/> No</p> <p><input type="checkbox"/> Yes <input type="checkbox"/> No</p> <p><input type="checkbox"/> Yes <input type="checkbox"/> No</p>		<p>Photo #:</p>	<ul style="list-style-type: none"> • Install tactile sign • Relocate sign •
---	---	---	-----------------	--

<p>Note: Signs are permitted on the push side of doors with closers and without hold-open devices.</p> <p>With clear floor space beyond the arc of the door swing between the closed position and 45-degree open position, at least 18 x 18 inches centered on the tactile characters?*</p> <p>So the baseline of the lowest character is at least 48 inches above the floor and the baseline of the highest character is no more than 60 inches above the floor? *</p> <p>Note: If the sign is at double doors with one active leaf, the sign should be on the inactive leaf; if both leaves are active, the sign should be on the wall to the right of the right leaf.</p>	<p><input type="checkbox"/> Yes <input type="checkbox"/> No</p> <p>Measurement:</p> <p><input type="checkbox"/> Yes <input type="checkbox"/> No</p> <p>Measurement:</p>		<p>Photo #:</p> <p>*If constructed before 3/15/2010 and a person may approach within 3 inches of the sign without encountering protruding objects or standing within the door swing, relocation not required</p> <p>*If constructed before 3/15/2012 and mounted no higher than 60 inches to the centerline of the sign, relocation not required</p>
<p>2.39 If there are signs that provide direction to or information about interior spaces:</p> <p>Do text characters contrast with their backgrounds?</p> <p>Is the sign mounted so that characters are at least 40 inches above the floor?</p>	<p><input type="checkbox"/> Yes <input type="checkbox"/> No</p> <p><input type="checkbox"/> Yes <input type="checkbox"/> No</p> <p>Measurement:</p>		<p>Photo #:</p> <ul style="list-style-type: none"> • Install signs with contrasting characters • Change sign height • <p>Raised characters and Braille are not required</p>

Interior Doors – to classrooms, medical exam rooms, conference rooms, etc. (2010 Standards – 404)				
<p>2.40 Is the door opening width at least 32 inches clear, between the face of the door and the stop, when the door is open 90 degrees?</p>	<p><input type="checkbox"/> Yes <input type="checkbox"/> No</p> <p>Measurement:</p>		<p>Photo #:</p>	<ul style="list-style-type: none"> • Install offset hinges • Alter the doorway •
<p>2.41 If there is a front approach to the pull side of the door, is there at least 18 inches of maneuvering clearance beyond the latch side plus at least 60 inches clear depth?</p> <p>On both sides of the door, is the floor surface of the maneuvering clearance level (no steeper than 1:48)?</p>	<p><input type="checkbox"/> Yes <input type="checkbox"/> No</p> <p>Measurement:</p> <p><input type="checkbox"/> Yes <input type="checkbox"/> No</p> <p>Measurement:</p>		<p>Photo #:</p>	<ul style="list-style-type: none"> • Remove obstructions • Reconfigure walls • Add automatic door opener <p>See 2010 Standards 404.2.4 for maneuvering clearance requirements on the push side of the door and side approaches to the pull side of the door</p>
<p>2.42 Is the door threshold edge no more than ¼ inch high?</p> <p>Or</p> <p>No more than ¾ inch high if slope is beveled no steeper than 1:2?</p> <p>Note: The first ¼ inch of the threshold may be vertical; the rest must be beveled.</p>	<p><input type="checkbox"/> Yes <input type="checkbox"/> No</p> <p>Measurement:</p> <p><input type="checkbox"/> Yes <input type="checkbox"/> No</p> <p>Measurement:</p>		<p>Photo #:</p>	<ul style="list-style-type: none"> • Remove or replace threshold • •

<p>2.43 Is the door equipped with hardware that is operable with one hand and does not require tight grasping, pinching and twisting of the wrist?</p>	<p><input type="checkbox"/> Yes <input type="checkbox"/> No</p>		<p>Photo #:</p>	<ul style="list-style-type: none"> • Replace inaccessible knob with lever, loop or push hardware • Add automatic door opener •
<p>2.44 Are the operable parts of the hardware no less than 34 inches and no greater than 48 inches above the floor?</p>	<p><input type="checkbox"/> Yes <input type="checkbox"/> No</p> <p>Measurement:</p>		<p>Photo #:</p>	<ul style="list-style-type: none"> • Change hardware height • •
<p>2.45 Can the door be opened easily (5 pounds maximum force)?</p> <p>Note: You can use a pressure gauge or fish scale to measure force. If you do not have a pressure gauge or fish scale you will need to judge whether the door is easy to open.</p>	<p><input type="checkbox"/> Yes <input type="checkbox"/> No</p> <p>Measurement:</p>		<p>Photo #:</p>	<ul style="list-style-type: none"> • Adjust or replace closers • Install lighter doors • Install power-assisted or automatic door openers
<p>2.46 If the door has a closer, does it take at least 5 seconds to close from an open position of 90 degrees to a position of 12 degrees from the latch?</p>	<p><input type="checkbox"/> Yes <input type="checkbox"/> No</p> <p>Measurement:</p>		<p>Photo #:</p>	<ul style="list-style-type: none"> • Adjust closer • •

Rooms and Spaces – stores, supermarkets, libraries, etc. (2010 Standards – 302, 304, & 402)

<p>2.47 Are aisles and pathways to goods and services, and to one of each type of sales and service counters, at least 36 inches wide?</p>	<p><input type="checkbox"/> Yes <input type="checkbox"/> No</p> <p>Measurement:</p>		<p>Photo #:</p>	<ul style="list-style-type: none"> • Rearrange goods, equipment and furniture • •
<p>2.48 Are floor surfaces stable, firm and slip resistant?</p>	<p><input type="checkbox"/> Yes <input type="checkbox"/> No</p>		<p>Photo #:</p>	<ul style="list-style-type: none"> • Change floor surface • •
<p>2.49 If there is carpet:</p> <p>Is it no higher than ½ inch?</p> <p>Is it securely attached along the edges?</p>	<p><input type="checkbox"/> Yes <input type="checkbox"/> No</p> <p>Measurement:</p> <p><input type="checkbox"/> Yes <input type="checkbox"/> No</p>		<p>Photo #:</p>	<ul style="list-style-type: none"> • Replace carpet • •

Controls – light switches, security and intercom systems, emergency/alarm boxes, etc. (2010 Standards – 309)

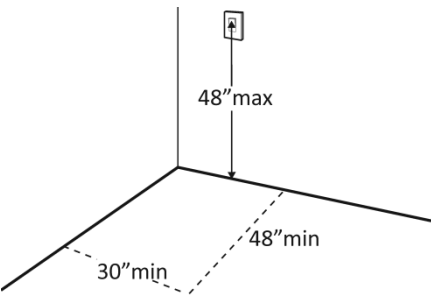
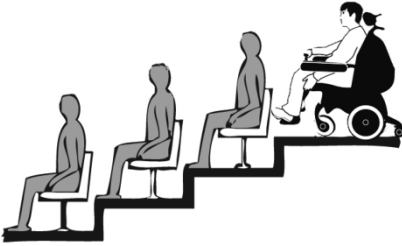
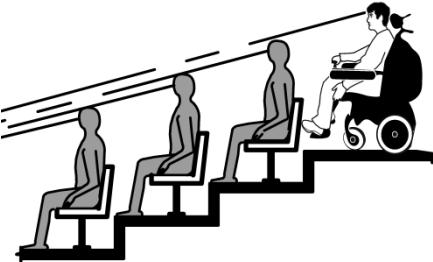
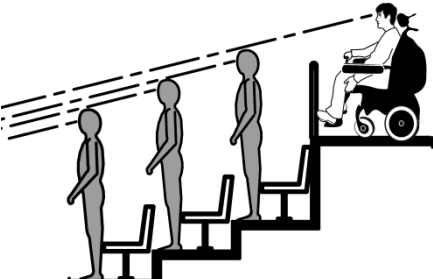

<p>2.50 Is there a clear floor space at least 30 inches wide by at least 48 inches long for a forward or parallel approach?</p> <p>Are the operable parts no higher than 48 inches above the floor?*</p>	<p><input type="checkbox"/> Yes <input type="checkbox"/> No</p> <p>Measurement:</p> <p><input type="checkbox"/> Yes <input type="checkbox"/> No</p> <p>Measurement:</p>		<p>Photo #:</p>	<ul style="list-style-type: none"> • Change height of control • • <p>*If constructed before 3/15/2012 and a parallel approach is provided, controls can be 54 inches above the floor</p>
---	---	--	-----------------	---

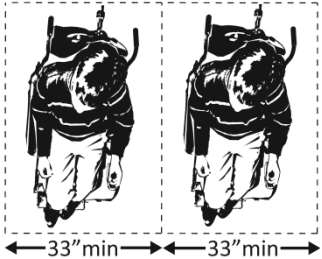
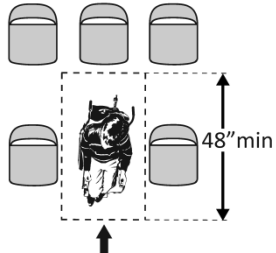
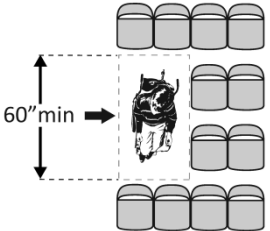
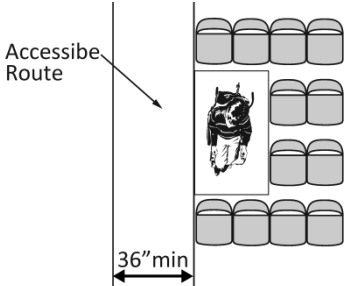
			Photo #:
--	--	--	----------

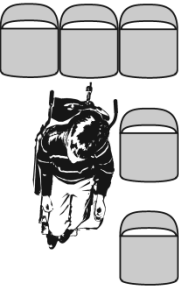

<p>2.51 Can the control be operated with one hand and without tight grasping, pinching, or twisting of the wrist?</p>	<input type="checkbox"/> Yes <input type="checkbox"/> No		<p>Photo #:</p> <ul style="list-style-type: none"> • Replace control • •
--	--	--	---

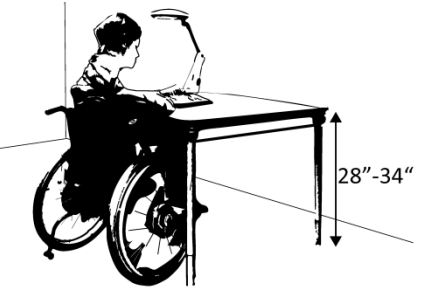
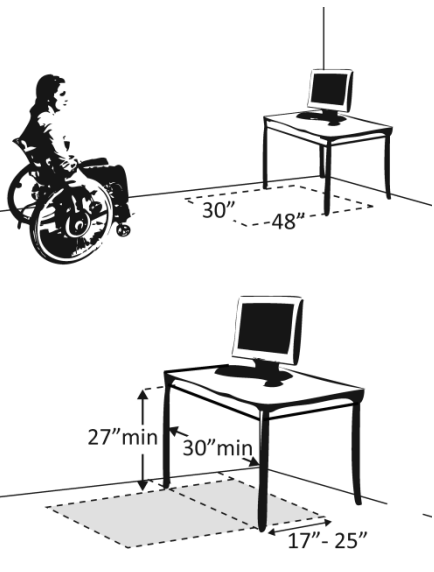
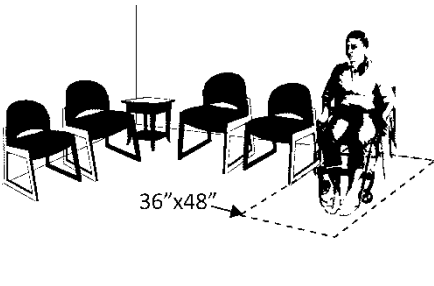
Seating: Assembly Areas – theaters, auditoriums, stadiums, theater style classrooms, etc. (2010 Standards – 221 & 802)

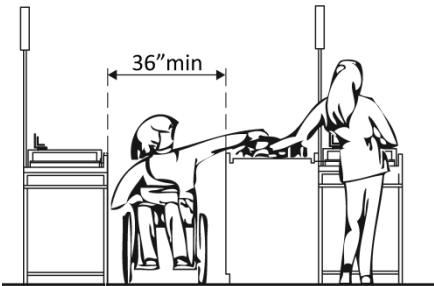
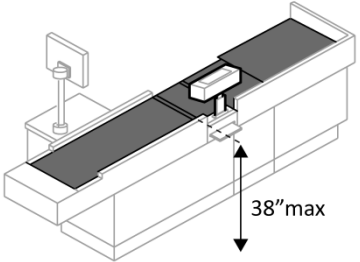
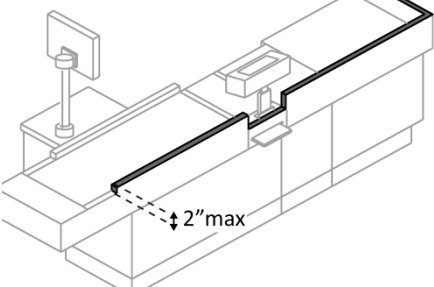
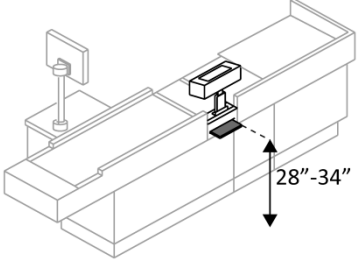
<p>2.52 Are an adequate number of wheelchair spaces provided?</p>	<input type="checkbox"/> Yes <input type="checkbox"/> No	<table border="1"> <thead> <tr> <th># of Seats</th> <th>Wheelchair Spaces</th> </tr> </thead> <tbody> <tr> <td>4 - 25</td> <td>1</td> </tr> <tr> <td>26 - 50</td> <td>2</td> </tr> <tr> <td>51 - 150</td> <td>4</td> </tr> <tr> <td>151 - 300</td> <td>5</td> </tr> <tr> <td>300+ see 2010 Standards 221.2.1.</td> <td></td> </tr> </tbody> </table>	# of Seats	Wheelchair Spaces	4 - 25	1	26 - 50	2	51 - 150	4	151 - 300	5	300+ see 2010 Standards 221.2.1.		<p>Photo #:</p> <ul style="list-style-type: none"> • Reconfigure to add wheelchair spaces • •
# of Seats	Wheelchair Spaces														
4 - 25	1														
26 - 50	2														
51 - 150	4														
151 - 300	5														
300+ see 2010 Standards 221.2.1.															


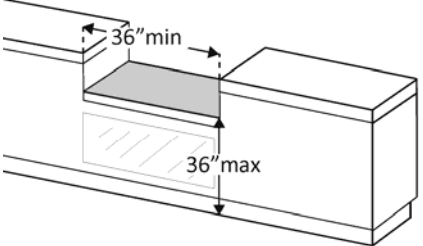
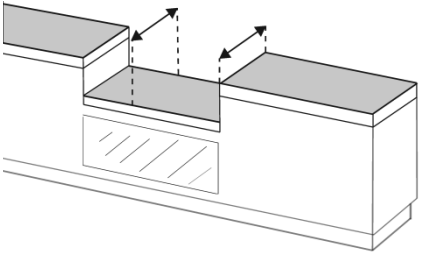
<p>2.53 Are wheelchair spaces dispersed to allow location choices and viewing angles equivalent to other seating, including specialty seating areas that provide distinct services and amenities?</p>	<p><input type="checkbox"/> Yes <input type="checkbox"/> No</p>		<p>Photo #:</p>	<ul style="list-style-type: none"> • Reconfigure to disperse wheelchair spaces • •
<p>2.54 Where people are expected to remain seated, do people in wheelchair spaces have a clear line of sight over and between the heads of others in front of them?</p>	<p><input type="checkbox"/> Yes <input type="checkbox"/> No</p>		<p>Photo #:</p>	<ul style="list-style-type: none"> • Alter for line of sight • •
<p>2.55 Where people are expected to stand, do people in wheelchair spaces have a clear line of sight over and between the heads of others in front of them?</p>	<p><input type="checkbox"/> Yes <input type="checkbox"/> No</p>		<p>Photo #:</p>	<ul style="list-style-type: none"> • Alter for line of sight • •
<p>2.56 If there is a single wheelchair space, is it at least 36 inches wide?</p>	<p><input type="checkbox"/> Yes <input type="checkbox"/> No</p> <p>Measurement:</p>	 <p>← 36" min →</p>	<p>Photo #:</p>	<ul style="list-style-type: none"> • Alter space • •

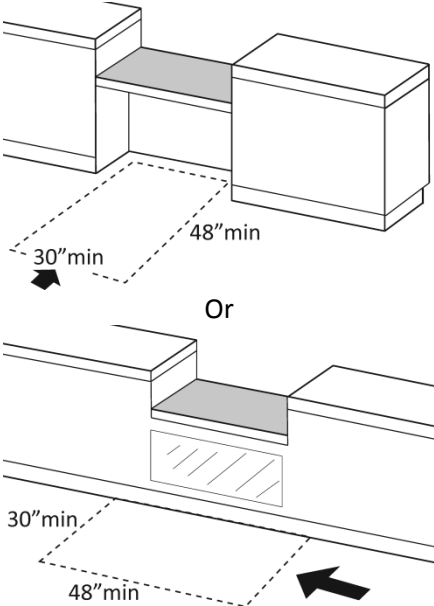
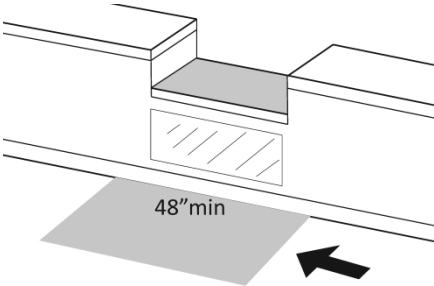
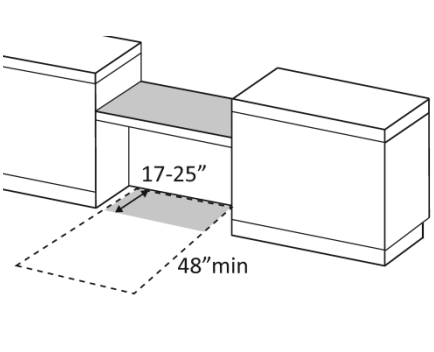
<p>2.57 If there are two adjacent wheelchair spaces, are they each at least 33 inches wide?</p>	<p><input type="checkbox"/> Yes <input type="checkbox"/> No</p> <p>Measurement:</p>		<p>Photo #:</p>	<ul style="list-style-type: none"> • Alter spaces • •
<p>2.58 If the wheelchair space can be entered from the front or rear, is it at least 48 inches deep?</p>	<p><input type="checkbox"/> Yes <input type="checkbox"/> No</p> <p>Measurement:</p>		<p>Photo #:</p>	<ul style="list-style-type: none"> • Alter space • •
<p>2.59 If the wheelchair space can only be entered from the side, is it at least 60 inches deep?</p>	<p><input type="checkbox"/> Yes <input type="checkbox"/> No</p> <p>Measurement:</p>		<p>Photo #:</p>	<ul style="list-style-type: none"> • Alter space • •
<p>2.60 Do wheelchair spaces adjoin, but not overlap, accessible routes?</p>	<p><input type="checkbox"/> Yes <input type="checkbox"/> No</p>		<p>Photo #:</p>	<ul style="list-style-type: none"> • Alter spaces • •

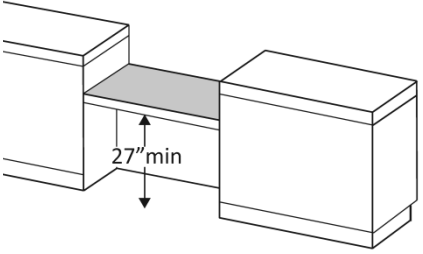
<p>2.61 Is there at least one companion seat for each wheelchair space?</p>	<p><input type="checkbox"/> Yes <input type="checkbox"/> No</p>		<p>Photo #:</p>	<ul style="list-style-type: none"> • Add companion seats • •
<p>2.62 Is the companion seat located so the companion is shoulder-to-shoulder with the person in a wheelchair?</p>	<p><input type="checkbox"/> Yes <input type="checkbox"/> No</p>		<p>Photo #:</p>	<ul style="list-style-type: none"> • Alter seating • •
<p>2.63 Is the companion seat equivalent in size, quality, comfort and amenities to seating in the immediate area?</p>	<p><input type="checkbox"/> Yes <input type="checkbox"/> No</p>		<p>Photo #:</p>	<ul style="list-style-type: none"> • Add equivalent seating • •
<p>Seating: At dining surfaces (restaurants, cafeterias, bars, etc.) and non-employee work surfaces (libraries, conference rooms, etc.) (2010 Standards – 226 & 902)</p>				
<p>2.64 Are at least 5%, but no fewer than one, of seating and standing spaces accessible for people who use wheelchairs?</p>	<p><input type="checkbox"/> Yes <input type="checkbox"/> No</p> <p>Total #:</p> <p>Wheelchair #:</p>		<p>Photo #:</p>	<ul style="list-style-type: none"> • Alter to provide accessible spaces • •
<p>2.65 Is there a route at least 36 inches wide to accessible seating?</p>	<p><input type="checkbox"/> Yes <input type="checkbox"/> No</p> <p>Measurement:</p>		<p>Photo #:</p>	<ul style="list-style-type: none"> • Widen route • •

<p>2.66 At the accessible space(s), is the top of the accessible surface no less than 28 inches and no greater than 34 inches above the floor?</p>	<p><input type="checkbox"/> Yes <input type="checkbox"/> No</p> <p>Measurement:</p>		<p>Photo #:</p>	<ul style="list-style-type: none"> • Alter surface height • •
<p>2.67 Is there a clear floor space at least 30 inches wide by at least 48 inches long for a forward approach?</p> <p>Does it extend no less than 17 inches and no greater than 25 inches under the surface?</p> <p>Is there knee space at least 27 inches high and at least 30 inches wide?</p>	<p><input type="checkbox"/> Yes <input type="checkbox"/> No</p> <p>Measurement:</p> <p><input type="checkbox"/> Yes <input type="checkbox"/> No</p> <p>Measurement:</p> <p><input type="checkbox"/> Yes <input type="checkbox"/> No</p> <p>Measurement:</p>		<p>Photo #:</p>	<ul style="list-style-type: none"> • Alter table or work surface • Add accessible table or work surface •
<p>Seating: General – reception areas, waiting rooms, etc. (2010 Standards – 801)</p>				
<p>2.68 Is there at least one space at least 36 inches wide by at least 48 inches long for a person in a wheelchair?</p>	<p><input type="checkbox"/> Yes <input type="checkbox"/> No</p> <p>Measurement:</p>		<p>Photo #:</p>	<ul style="list-style-type: none"> • Move furniture and equipment to provide space • •

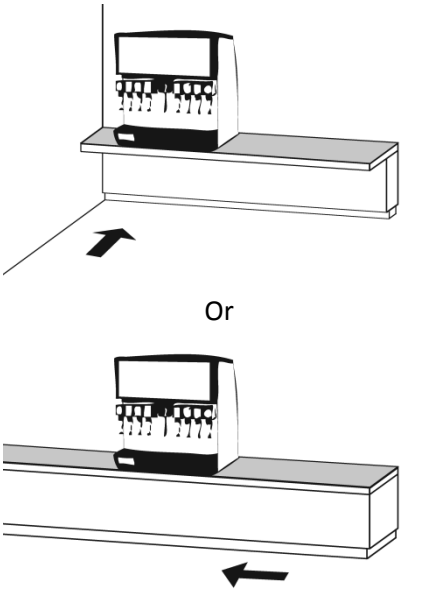
Check-Out Aisles – supermarkets, large retail stores, etc. (2010 Standards – 904)				
<p>2.71 Is the aisle at least 36 inches wide?</p>	<p><input type="checkbox"/> Yes <input type="checkbox"/> No</p> <p>Measurement:</p>		<p>Photo #:</p>	<ul style="list-style-type: none"> • Widen aisle • •
<p>2.72 Is the counter surface of at least one aisle no higher than 38 inches above the floor?</p>	<p><input type="checkbox"/> Yes <input type="checkbox"/> No</p> <p>Measurement:</p>		<p>Photo #:</p>	<ul style="list-style-type: none"> • Lower counter • •
<p>2.73 Is the top of the counter edge protection no higher than 2 inches above the counter surface?</p>	<p><input type="checkbox"/> Yes <input type="checkbox"/> No</p> <p>Measurement:</p>		<p>Photo #:</p>	<ul style="list-style-type: none"> • Lower edge protection • •
<p>2.74 If there is a check writing surface, is the top no less than 28 inches and no greater than 34 inches above the floor?</p>	<p><input type="checkbox"/> Yes <input type="checkbox"/> No</p> <p>Measurement:</p>		<p>Photo #:</p>	<ul style="list-style-type: none"> • Alter check writing surface • •

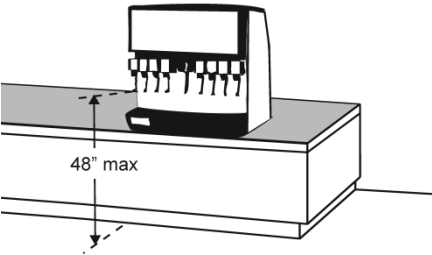
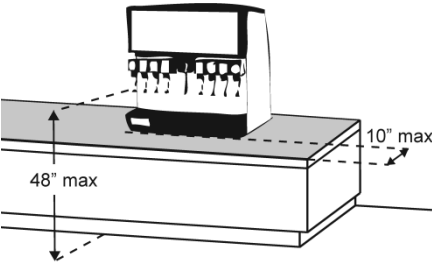
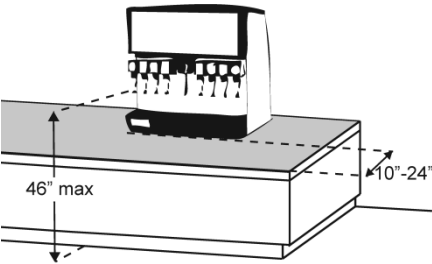
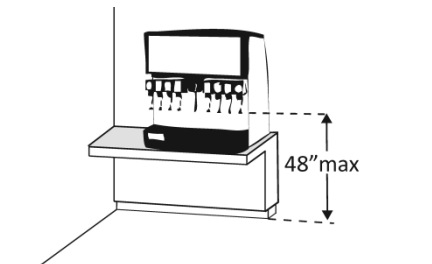
<p>2.75 If there is more than one check-out aisle is there a sign with the International Symbol of Accessibility at the accessible aisle?</p>	<p><input type="checkbox"/> Yes <input type="checkbox"/> No</p>		<p>Photo #:</p>	<ul style="list-style-type: none"> • Add sign • •
<p>Sales & Service Counters – banks, stores, dry cleaners, auto repair shops, fitness clubs, etc. (2010 Standards – 904)</p>				
<p>2.76 Is there a portion of at least one of each type of counter that is:</p> <p>No higher than 36 inches above the floor?</p> <p>At least 36 inches long?</p>	<p><input type="checkbox"/> Yes <input type="checkbox"/> No</p> <p>Measurement:</p> <p><input type="checkbox"/> Yes <input type="checkbox"/> No</p> <p>Measurement:</p>		<p>Photo #:</p>	<ul style="list-style-type: none"> • Lower section of counter • Lengthen section of counter •
<p>2.77 Does the accessible portion of the counter extend the same depth as the counter top?</p>	<p><input type="checkbox"/> Yes <input type="checkbox"/> No</p> <p>Measurement:</p>		<p>Photo #:</p>	<ul style="list-style-type: none"> • Alter accessible portion • •

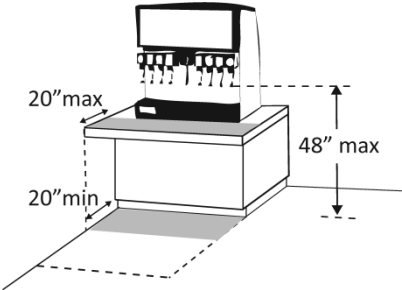
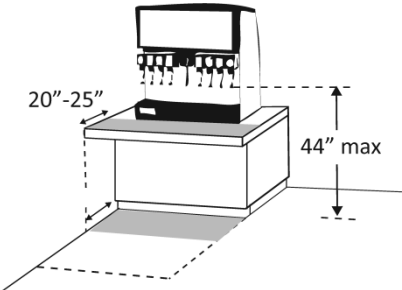
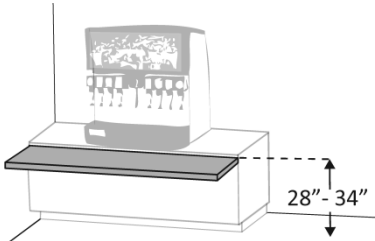
<p>2.78 Is there a clear floor space at least 30 inches wide by at least 48 inches long for a forward or parallel approach?</p>	<p><input type="checkbox"/> Yes <input type="checkbox"/> No</p> <p><input type="checkbox"/> Parallel Measurement:</p> <p><input type="checkbox"/> Forward Measurement:</p>		<p>Photo #:</p>	<ul style="list-style-type: none"> • Reconfigure to provide a parallel or forward approach • •
<p>2.79 For a parallel approach, is the clear floor space positioned with the 48 inches adjacent to the accessible length of counter?</p>	<p><input type="checkbox"/> Yes <input type="checkbox"/> No</p> <p>Measurement:</p>		<p>Photo #:</p>	<ul style="list-style-type: none"> • If a parallel approach is not possible, a forward approach is required • •
<p>2.80 For a forward approach:</p> <p>Do no less than 17 and no greater than 25 inches of the clear floor space extend under the accessible length of the counter?</p> <p>Is there at least 27 inches clearance from the floor to the</p>	<p><input type="checkbox"/> Yes <input type="checkbox"/> No</p> <p>Measurement:</p> <p><input type="checkbox"/> Yes <input type="checkbox"/> No</p>		<p>Photo #:</p>	<ul style="list-style-type: none"> • Reconfigure to provide knee clearance • •

<p>bottom of the counter?</p>	<p>Measurement:</p>		<p>Photo #:</p>	
-------------------------------	---------------------	--	-----------------	--

Food Service Lines – in cafeterias, salad bars, eat-in fast food establishments, etc. (2010 Standards – 904)

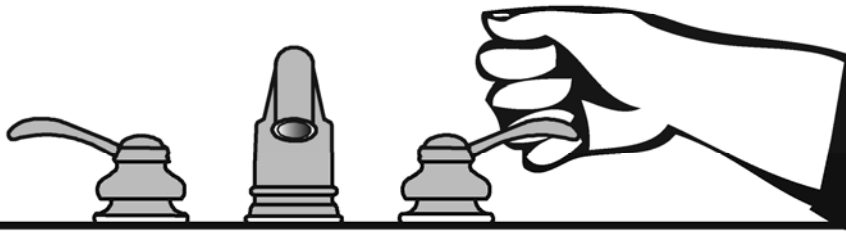
<p>2.81 Does at least one of each type of self-service shelf or dispensing device for tableware, dishware, condiments, food and beverages have a forward or parallel approach?</p>	<p><input type="checkbox"/> Yes <input type="checkbox"/> No</p> <p><input type="checkbox"/> Forward</p> <p><input type="checkbox"/> Parallel</p>		<p>Photo #:</p>	<ul style="list-style-type: none"> • Reconfigure to provide approach • •
---	--	---	-----------------	---

<p>2.82 If there is an unobstructed parallel approach, is the shelf or dispensing device no higher than 48 inches above the floor?</p>	<p><input type="checkbox"/> Yes <input type="checkbox"/> No</p> <p>Measurement:</p>		<p>Photo #:</p>	<ul style="list-style-type: none"> • Lower shelf and/or dispensing device • •
<p>2.83 If there is a shallow obstruction no deeper than 10 inches with a parallel approach, is the shelf or dispensing device no higher than 48 inches above the floor?</p>	<p><input type="checkbox"/> Yes <input type="checkbox"/> No</p> <p>Measurement:</p>		<p>Photo #:</p>	<ul style="list-style-type: none"> • Lower shelf and/or dispensing device • •
<p>2.84 If there is an obstruction no less than 10 inches and no greater than 24 inches deep with a parallel approach, is the shelf or dispensing device no higher than 46 inches above the floor?</p>	<p><input type="checkbox"/> Yes <input type="checkbox"/> No</p> <p>Measurement:</p>		<p>Photo #:</p>	<ul style="list-style-type: none"> • Lower shelf and/or dispensing device • •
<p>2.85 If there is an unobstructed forward approach, is the shelf or dispensing device no higher than 48 inches above the floor?</p>	<p><input type="checkbox"/> Yes <input type="checkbox"/> No</p> <p>Measurement:</p>		<p>Photo #:</p>	<ul style="list-style-type: none"> • Lower shelf and/or dispensing device • •

<p>2.86 If there is an obstruction no deeper than 20 inches with a forward approach:</p> <p>Does clear floor space extend under the obstruction that is at least the same depth as the obstruction?</p> <p>Is the shelf or dispensing device no higher than 48 inches above the floor?</p>	<p><input type="checkbox"/> Yes <input type="checkbox"/> No Measurement:</p> <p><input type="checkbox"/> Yes <input type="checkbox"/> No Measurement:</p>		<p>Photo #:</p>	<ul style="list-style-type: none"> • Reconfigure to provide knee space • Lower shelf and/or dispensing device •
<p>2.87 If the obstruction is no less than 20 inches and no greater than 25 inches deep with a forward approach:</p> <p>Does clear floor space extend under the obstruction that is at least the same depth as the obstruction?</p> <p>Is the shelf or dispensing device no higher than 44 inches above the floor?</p>	<p><input type="checkbox"/> Yes <input type="checkbox"/> No Measurement:</p> <p><input type="checkbox"/> Yes <input type="checkbox"/> No Measurement:</p>		<p>Photo #:</p>	<ul style="list-style-type: none"> • Reconfigure to provide knee space • Lower shelf and/or dispensing device •
<p>2.88 If there is a tray slide, is the top no less than 28 inches and no greater than 34 inches above the floor?</p>	<p><input type="checkbox"/> Yes <input type="checkbox"/> No Measurement:</p>		<p>Photo #:</p>	<ul style="list-style-type: none"> • Reconfigure • •

The ADA Checklist for Readily Achievable Barrier Removal

Priority 3 - Toilet Rooms



Project _____

Building _____

Location _____

Date _____

Surveyors _____

Contact Information _____

When toilet rooms are open to the public they should be accessible to people with disabilities.



Institute for Human Centered Design
www.HumanCenteredDesign.org
November 2011





ADA National Network
Questions on the ADA 800-949-4232 voice/tty
www.ADAchecklist.org

This checklist was produced by the New England ADA Center, a project of the Institute for Human Centered Design and a member of the ADA National Network. This checklist was developed under a grant from the Department of Education, NIDRR grant number H133A060092-09A. However the contents do not necessarily represent the policy of the Department of Education, and you should not assume endorsement by the Federal Government.

Questions or comments on the checklist contact the New England ADA Center at 617-695-0085 voice/tty or ADAinfo@NewEnglandADA.org

For the full set of checklists, including the checklists for recreation facilities visit www.ADAchecklist.org.

Priority 3 – Toilet Rooms		Comments	Possible Solutions
<p>3.1 If toilet rooms are available to the public, is at least one toilet room accessible? (Either one for each sex, or one unisex.)</p> <p><input type="checkbox"/> Yes <input type="checkbox"/> No</p>		Photo #:	<ul style="list-style-type: none"> • Reconfigure toilet rooms • Combine toilet rooms to create one unisex accessible toilet room •
<p>3.2 Are there signs at inaccessible toilet rooms that give directions to accessible toilet rooms?</p> <p><input type="checkbox"/> Yes <input type="checkbox"/> No</p>		Photo #:	<ul style="list-style-type: none"> • Install signs • •
<p>3.3 If not all toilet rooms are accessible, is there a sign at the accessible toilet room with the International Symbol of Accessibility?</p> <p><input type="checkbox"/> Yes <input type="checkbox"/> No</p>		Photo #:	<ul style="list-style-type: none"> • Install sign • •
<p>Accessible Route (2010 Standards – Chapter 4)</p>			
<p>3.4 Is there a route to the accessible toilet room(s) that does not include the use of stairs?</p> <p><input type="checkbox"/> Yes <input type="checkbox"/> No</p> <p>Is the route accessible? (See Priority 2 Interior Accessible Route for specifics.)</p> <p><input type="checkbox"/> Yes <input type="checkbox"/> No</p>		Photo #:	<ul style="list-style-type: none"> • Alter route • •

Signs at Toilet Rooms (2010 Standards – 703)

3.5 Do text characters contrast with their backgrounds?

Yes No

Are text characters raised?

Yes No

Is there Braille?

Yes No

Is the sign mounted:
On the wall on the latch side of the door?

Yes No

Note:

Signs are permitted on the push side of doors with closers and without hold-open devices.

With clear floor space beyond the arc of the door swing and 45-degree open position, at least 18 x 18 inches centered on the tactile characters? *

Yes No

Measurement:

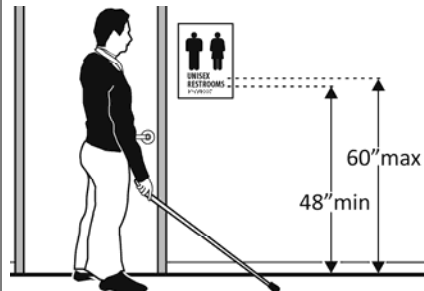
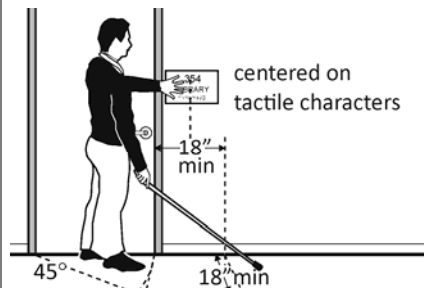
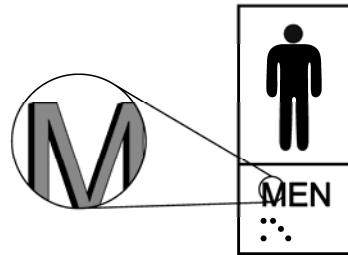
So the baseline of the lowest character is at least 48 inches above the floor and the baseline of the highest character is no more than 60 inches above the floor? *

Yes No

Measurement:

Note:

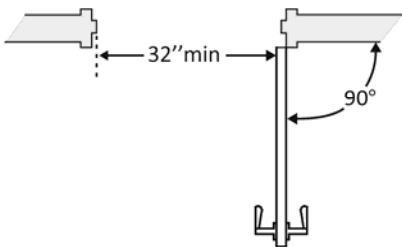
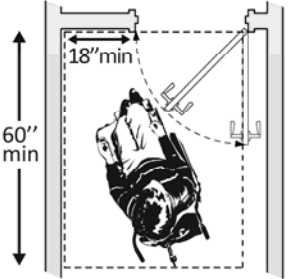
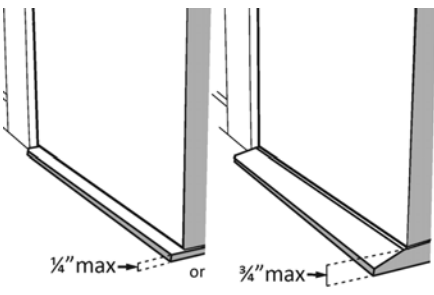
If the sign is at double doors with one active leaf, the sign should be on the inactive leaf; if both leaves are active, the sign

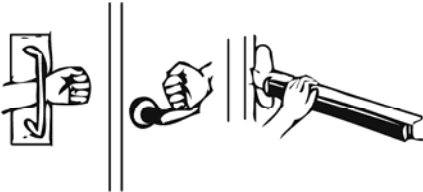
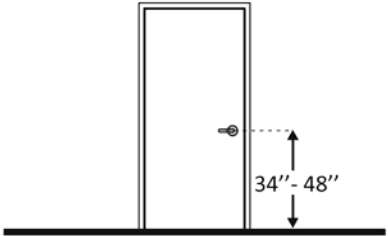

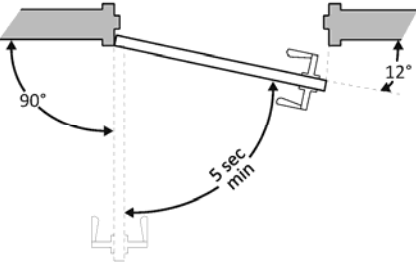


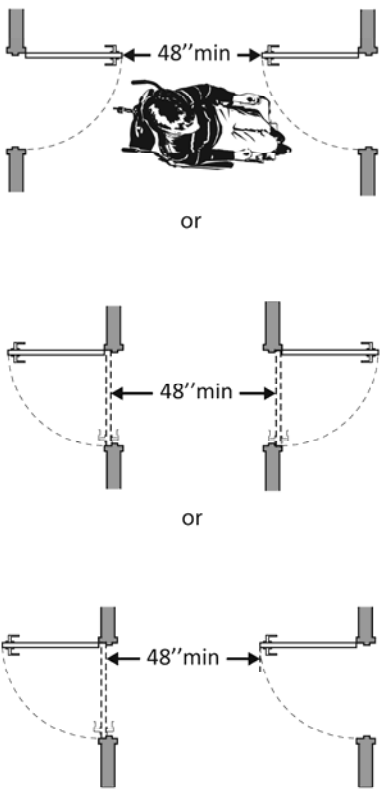
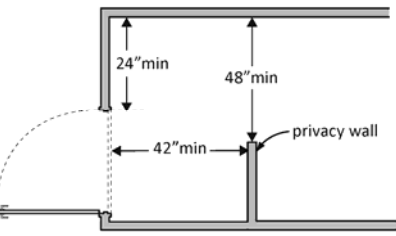
- Install tactile sign
- Relocate sign
-

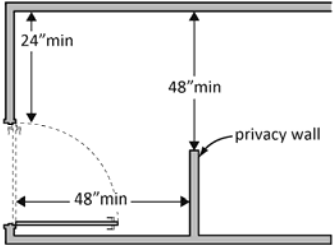

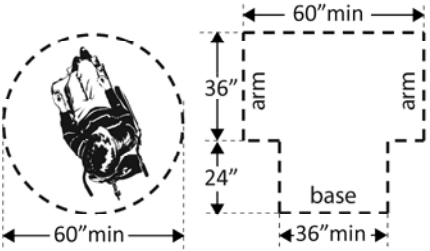
*If constructed before 3/15/2010 and a person may approach within 3 inches of the sign without encountering protruding objects or standing within the door swing, relocation not required

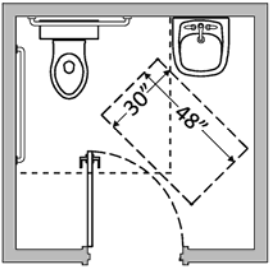
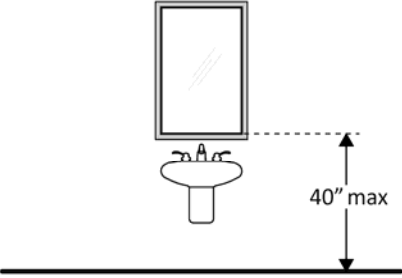
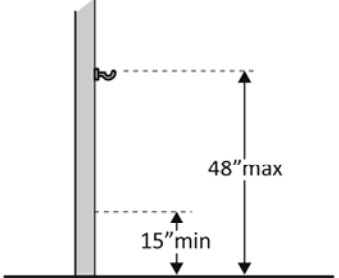
*If constructed before 3/15/2012 and mounted no higher than 60 inches to the centerline of the sign, relocation is not required

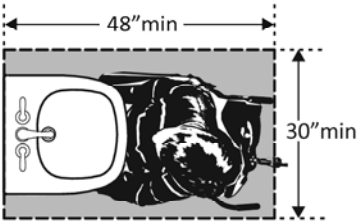
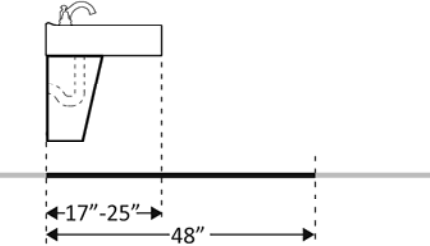
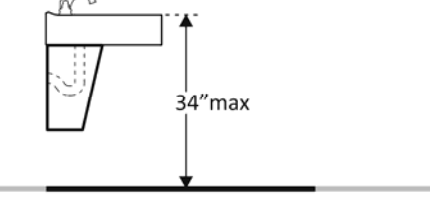
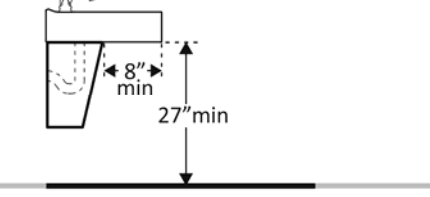
<p>should be on the wall to the right of the right leaf.</p>			<p>Photo #:</p>	
<p>Entrance (2010 Standards – 404)</p>				
<p>3.6 Is the door opening width at least 32 inches clear, between the face of the door and the stop, when the door is open 90 degrees?</p>	<p><input type="checkbox"/> Yes <input type="checkbox"/> No</p> <p>Measurement:</p>		<p>Photo #:</p>	<ul style="list-style-type: none"> • Install offset hinges • Alter the doorway •
<p>3.7 If there is a front approach to the pull side of the door is there at least 18 inches of maneuvering clearance beyond the latch side plus 60 inches clear depth?</p> <p>On both sides of the door, is the floor surface of the maneuvering clearance level (no steeper than 1:48)?</p>	<p><input type="checkbox"/> Yes <input type="checkbox"/> No</p> <p>Measurement:</p> <p><input type="checkbox"/> Yes <input type="checkbox"/> No</p> <p>Measurement:</p>		<p>Photo #:</p>	<ul style="list-style-type: none"> • Remove obstructions • Reconfigure walls • Add automatic door opener <p>See 2010 Standards 404.2.4 for maneuvering clearance requirements on the push side of the door and side approaches to the pull side of the door</p>
<p>3.8 Is the door threshold edge no more than ¼ inch high?</p> <p>Or</p> <p>No more than ¾ inch high if slope is beveled no steeper than 1:2?</p> <p>Note: The first ¼ inch of the threshold may be vertical; the rest must be beveled.</p>	<p><input type="checkbox"/> Yes <input type="checkbox"/> No</p> <p>Measurement:</p> <p><input type="checkbox"/> Yes <input type="checkbox"/> No</p> <p>Measurement:</p>		<p>Photo #:</p>	<ul style="list-style-type: none"> • Remove or replace threshold • •

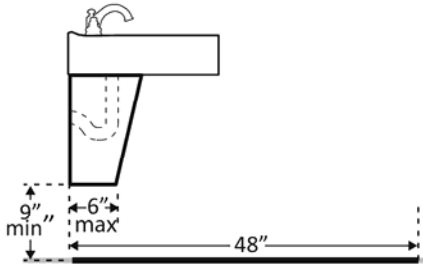
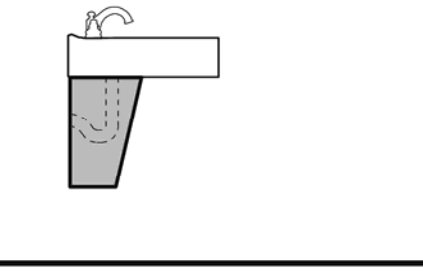
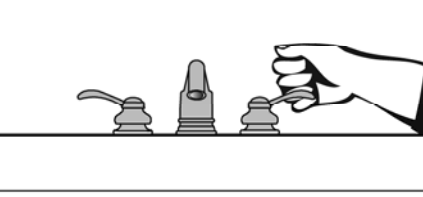
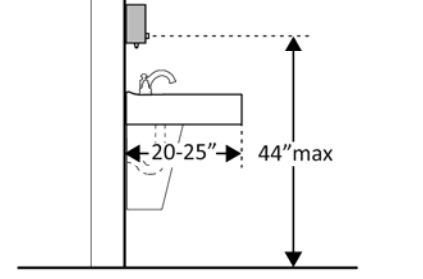
<p>3.9 Is the door equipped with hardware that is operable with one hand and does not require tight grasping, pinching, or twisting of the wrist? Check door handle and lock (if provided).</p>	<p><input type="checkbox"/> Yes <input type="checkbox"/> No</p> <p>Measurement:</p>		<p>Photo #:</p>	<ul style="list-style-type: none"> • Replace knobs or latches with lever or loop handles • Install power-assisted or automatic door openers •
<p>3.10 Are the operable parts of the door hardware mounted no less than 34 inches and no greater than 48 inches above the floor?</p>	<p><input type="checkbox"/> Yes <input type="checkbox"/> No</p> <p>Measurement:</p>		<p>Photo #:</p>	<ul style="list-style-type: none"> • Change hardware height • •
<p>3.11 Can the door be opened easily (5 pounds maximum force)?</p>	<p><input type="checkbox"/> Yes <input type="checkbox"/> No</p> <p>Measurement:</p>		<p>Photo #:</p>	<ul style="list-style-type: none"> • Adjust or replace closers • Install lighter doors • Install power-assisted or automatic door openers
<p>3.12 If the door has a closer, does it take at least 5 seconds to close from an open position of 90 degrees to a position of 12 degrees from the latch?</p>	<p><input type="checkbox"/> Yes <input type="checkbox"/> No</p> <p>Measurement:</p>		<p>Photo #:</p>	<ul style="list-style-type: none"> • Adjust closer • •

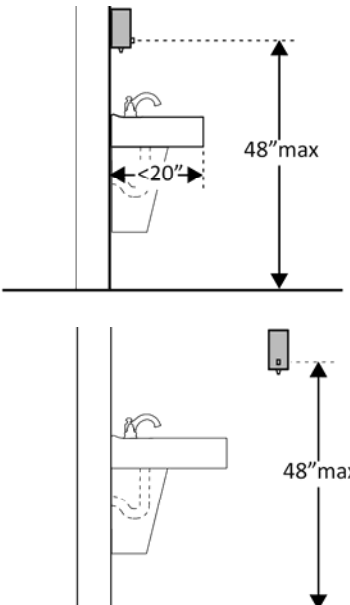
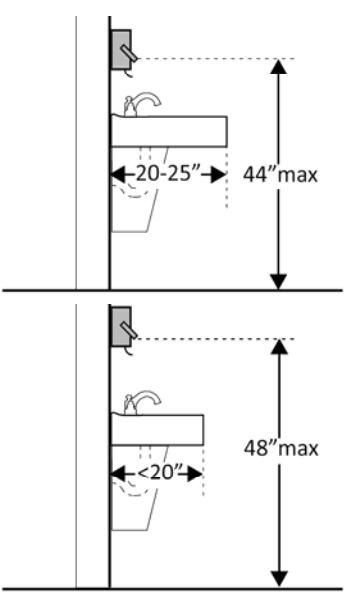
<p>3.13 If there are two doors in a series, e.g. vestibule, is the distance between the doors at least 48 inches plus the width of the doors when swinging into the space?</p>	<p><input type="checkbox"/> Yes <input type="checkbox"/> No</p> <p>Measurement:</p>		<p>Photo #:</p>	<ul style="list-style-type: none"> • Remove inner door • Change door swing •
<p>3.14 If there is a privacy wall and the door swings out, is there at least 24 inches of maneuvering clearance beyond the door latch side and 42 inches to the privacy wall?</p>	<p><input type="checkbox"/> Yes <input type="checkbox"/> No</p> <p>Measurement:</p>		<p>Photo #:</p>	<ul style="list-style-type: none"> • Reconfigure space • •

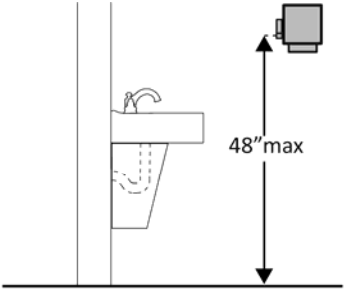
<p>3.15 If there is a privacy wall and the door swings in, is there at least 24 inches of maneuvering clearance beyond the door latch side and at least 48 inches to the privacy wall if there is no door closer or at least 54 inches if there is a door closer?</p>	<p><input type="checkbox"/> Yes <input type="checkbox"/> No</p> <p>Measurement:</p>		<p>Photo #:</p>	<ul style="list-style-type: none"> • Reconfigure space • •
<p>In the Toilet Room</p>				
<p>3.16 Is there a clear path to at least one of each type of fixture, e.g. lavatory, hand dryer, etc., that is at least 36 inches wide?</p>	<p><input type="checkbox"/> Yes <input type="checkbox"/> No</p> <p>Measurement:</p>		<p>Photo #:</p>	<ul style="list-style-type: none"> • Remove obstructions • •
<p>3.17 Is there clear floor space available for a person in a wheelchair to turn around, i.e. a circle at least 60 inches in diameter or a T-shaped space within a 60-inch square?*</p>	<p><input type="checkbox"/> Yes <input type="checkbox"/> No</p> <p>Measurement:</p>		<p>Photo #:</p>	<p>*The door to the toilet room may swing into the required turning space</p> <ul style="list-style-type: none"> • Move or remove partitions, fixtures or objects such as trash cans • •

<p>3.18 In a single user toilet room if the door swings in and over a clear floor space at an accessible fixture, is there a clear floor space at least 30 x 48 inches beyond the swing of the door?</p>	<p><input type="checkbox"/> Yes <input type="checkbox"/> No</p> <p>Measurement:</p>		<p>Photo #:</p>	<ul style="list-style-type: none"> • Reverse door swing • Alter toilet room •
<p>3.19 If the mirror is over a lavatory or countertop, is the bottom edge of the reflecting surface no higher than 40 inches above the floor? Or If the mirror is not over the lavatory or countertop, is the bottom edge of the reflecting surface no higher than 35 inches above the floor?*</p>	<p><input type="checkbox"/> Yes <input type="checkbox"/> No</p> <p>Measurement:</p> <p><input type="checkbox"/> Yes <input type="checkbox"/> No</p> <p>Measurement:</p>		<p>Photo #:</p>	<p>* If installed before 3/15/2012 and the bottom edge of the reflecting surface is no higher than 40 inches above the floor, lowering the mirror to 35 inches is not required</p> <ul style="list-style-type: none"> • Lower the mirror • Add another mirror •
<p>3.20 If there is a coat hook, is it no less than 15 inches and no greater than 48 inches above the floor?</p>	<p><input type="checkbox"/> Yes <input type="checkbox"/> No</p> <p>Measurement:</p>		<p>Photo #:</p>	<ul style="list-style-type: none"> • Adjust hook • Replace with or provide additional accessible hook •

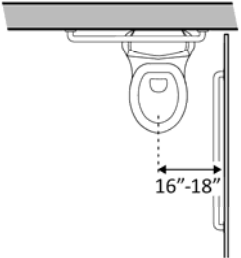
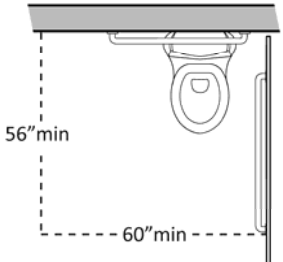
Lavatories (2010 Standards – 606) Note: 2010 Standards refer to sinks in toilet rooms as lavatories.				
<p>3.21 Does at least one lavatory have a clear floor space for a forward approach at least 30 inches wide and 48 inches long?</p>	<p><input type="checkbox"/> Yes <input type="checkbox"/> No</p> <p>Measurement:</p>		<p>Photo #:</p>	<ul style="list-style-type: none"> • Alter lavatory • Replace lavatory •
<p>3.22 Do no less than 17 inches and no greater than 25 inches of the clear floor space extend under the lavatory so that a person using a wheelchair can get close enough to reach the faucet?</p>	<p><input type="checkbox"/> Yes <input type="checkbox"/> No</p> <p>Measurement:</p>		<p>Photo #:</p>	<ul style="list-style-type: none"> • Alter lavatory • Replace lavatory •
<p>3.23 Is the front of the lavatory or counter surface, whichever is higher, no more than 34 inches above the floor?</p>	<p><input type="checkbox"/> Yes <input type="checkbox"/> No</p> <p>Measurement:</p>		<p>Photo #:</p>	<ul style="list-style-type: none"> • Alter lavatory • Replace lavatory •
<p>3.24 Is there at least 27 inches clearance from the floor to the bottom of the lavatory that extends at least 8 inches under the lav for knee clearance?</p>	<p><input type="checkbox"/> Yes <input type="checkbox"/> No</p> <p>Measurement:</p>		<p>Photo #:</p>	<ul style="list-style-type: none"> • Alter lavatory • Replace lavatory •

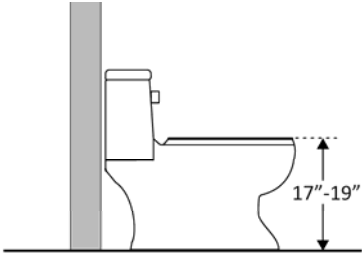
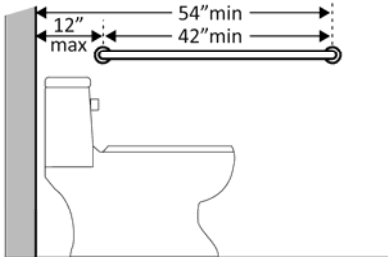
<p>3.25 Is there toe clearance at least 9 inches high? (Space extending greater than 6 inches beyond the available toe clearance at 9 inches above the floor is not considered toe clearance.)</p>	<p><input type="checkbox"/> Yes <input type="checkbox"/> No</p>		<p>Photo #:</p>	<ul style="list-style-type: none"> • Alter lavatory • Replace lavatory •
<p>3.26 Are pipes below the lavatory insulated or otherwise configured to protect against contact?</p>	<p><input type="checkbox"/> Yes <input type="checkbox"/> No</p>		<p>Photo #:</p>	<ul style="list-style-type: none"> • Install insulation • Install cover panel •
<p>3.27 Can the faucet be operated without tight grasping, pinching, or twisting of the wrist? Is the force required to activate the faucet no greater than 5 pounds?</p>	<p><input type="checkbox"/> Yes <input type="checkbox"/> No <input type="checkbox"/> Yes <input type="checkbox"/> No</p>		<p>Photo #:</p>	<ul style="list-style-type: none"> • Adjust faucet • Replace faucet •
<p>Soap Dispensers and Hand Dryers (2010 Standards – 603)</p>				
<p>3.28 Are the operable parts of the soap dispenser within one of the following reach ranges: Above lavatories or counters no less than 20 inches and no greater than 25 inches deep; no higher than 44 inches above the floor?</p>	<p><input type="checkbox"/> Yes <input type="checkbox"/> No Measurement:</p>		<p>Photo #:</p>	<ul style="list-style-type: none"> • Adjust dispensers • Replace with or provide additional accessible dispensers •

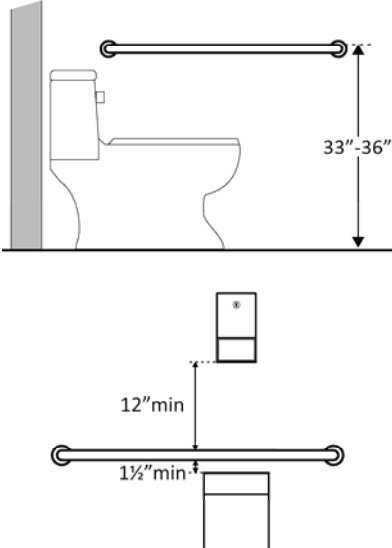
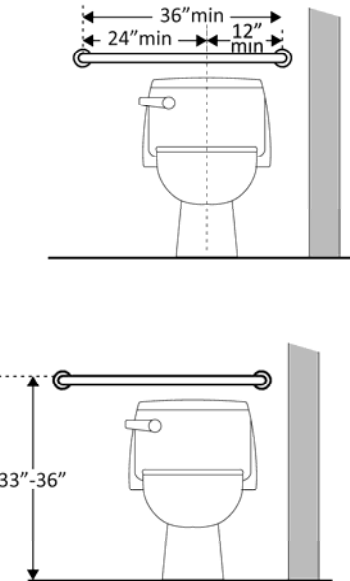
<p>Above lavatories less than 20 inches deep: no higher than 48 inches above the floor?</p> <p>Not over an obstruction: no higher than 48 inches above the floor?</p>	<p><input type="checkbox"/> Yes <input type="checkbox"/> No Measurement:</p> <p><input type="checkbox"/> Yes <input type="checkbox"/> No Measurement:</p>		<p>Photo #:</p>	
<p>3.29 Are the operable parts of the hand dryer or towel dispenser within one of the following reach ranges:</p> <p>Above lavatories or counters no less than 20 inches and no greater than 25 inches deep: no higher than 44 inches above the floor?</p> <p>Above lavatories less than 20 inches deep: no higher than 48 inches above the floor?</p> <p>Not over an obstruction: no higher than 48 inches above the floor?</p>	<p><input type="checkbox"/> Yes <input type="checkbox"/> No Measurement:</p> <p><input type="checkbox"/> Yes <input type="checkbox"/> No Measurement:</p> <p><input type="checkbox"/> Yes <input type="checkbox"/> No Measurement:</p>			<ul style="list-style-type: none"> • Adjust dispensers • Replace with or provide additional accessible dispensers •

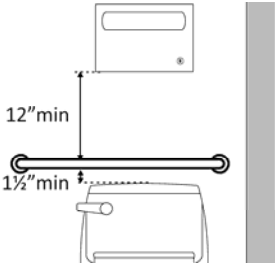
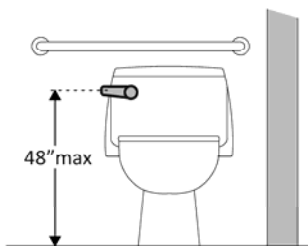
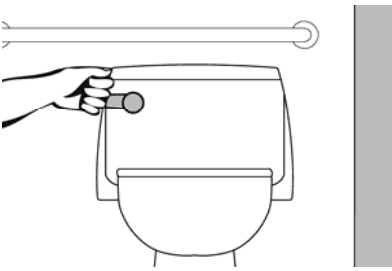
<p>Can the operable parts of the hand dryer or towel dispenser be operated without tight grasping, pinching or twisting of the wrist?</p> <p>Is the force required to activate the hand dryer or towel dispenser no greater than 5 pounds?</p>	<p><input type="checkbox"/> Yes <input type="checkbox"/> No</p> <p><input type="checkbox"/> Yes <input type="checkbox"/> No</p> <p>Measurement:</p>		<p>Photo #:</p>	
--	---	--	-----------------	--

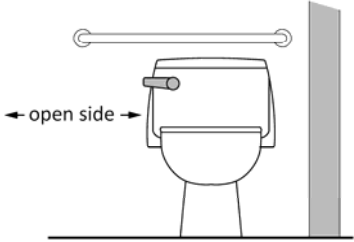
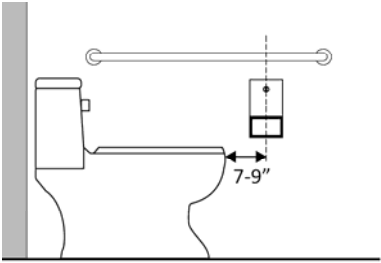
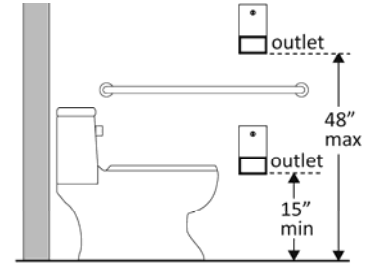
Water Closets in Single-User Toilet Rooms and Compartments (Stalls) (2010 Standards – 603 & 609) Note: 2010 Standards refer to toilets as water closets.

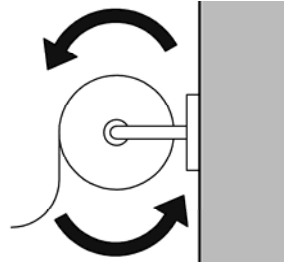
<p>3.30 Is the centerline of the water closet no less than 16 inches and no greater than 18 inches from the side wall or partition?</p>	<p><input type="checkbox"/> Yes <input type="checkbox"/> No</p> <p>Measurement:</p>		<p>Photo #:</p>	<ul style="list-style-type: none"> • Move toilet • Replace toilet • Move partition •
<p>3.31 Is clearance provided around the water closet measuring at least 60 inches from the side wall and at least 56 inches from the rear wall?*</p>	<p><input type="checkbox"/> Yes <input type="checkbox"/> No</p> <p>Measurement:</p>		<p>Photo #:</p>	<p>* If constructed before 3/15/12, clearances around water closets in single user toilet rooms can be 48 inches wide by 66 inches long or 48 inches wide by 56 inches long (depending on the approach to the water closet, see 1991 Standards Figure 28) and the lavatory may overlap that clearance if the door to the room does not swing into the</p>

			<p>Photo #:</p>	<p>required clearances at fixtures (such as lavatories, water closet and urinals) and the edge of the lavatory is at least 18 inches from the centerline of the water closet</p> <ul style="list-style-type: none"> • Alter room/compartment for clearance • •
<p>3.32 Is the height of the water closet no less than 17 inches and no greater than 19 inches above the floor measured to the top of the seat?</p>	<p><input type="checkbox"/> Yes <input type="checkbox"/> No</p> <p>Measurement:</p>		<p>Photo #:</p>	<ul style="list-style-type: none"> • Adjust toilet height • Replace toilet •
<p>3.33 Is there a grab bar at least 42 inches long on the side wall?</p> <p>Is it located no more than 12 inches from the rear wall?</p> <p>Does it extend at least 54 inches from the rear wall?</p> <p>Is it mounted no less than 33</p>	<p><input type="checkbox"/> Yes <input type="checkbox"/> No</p> <p>Measurement:</p> <p><input type="checkbox"/> Yes <input type="checkbox"/> No</p> <p>Measurement:</p> <p><input type="checkbox"/> Yes <input type="checkbox"/> No</p> <p>Measurement:</p> <p><input type="checkbox"/> Yes <input type="checkbox"/> No</p>		<p>Photo #:</p>	<ul style="list-style-type: none"> • Install grab bar • Relocate grab bar • Relocate objects •

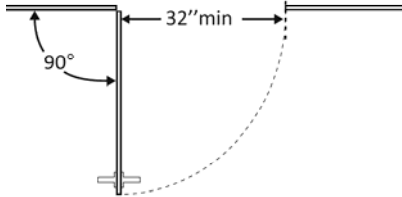
<p>inches and no greater than 36 inches above the floor to the top of the gripping surface?</p> <p>Is there at least 12 inches clearance between the grab bar and protruding objects above?*</p> <p>Is there at least 1½ inches clearance between the grab bar and projecting objects below?*</p> <p>Is the space between the wall and the grab bar 1 ½ inches?</p>	<p>Measurement:</p> <p><input type="checkbox"/> Yes <input type="checkbox"/> No</p> <p>Measurement:</p> <p><input type="checkbox"/> Yes <input type="checkbox"/> No</p> <p>Measurement:</p> <p><input type="checkbox"/> Yes <input type="checkbox"/> No</p> <p>Measurement:</p> <p><input type="checkbox"/> Yes <input type="checkbox"/> No</p>		<p>Photo #:</p>	<p>* If constructed before 3/15/2012 grab bars do not need to be relocated; there are no space requirements above and below grab bars in the 1991 Standards</p>
<p>3.34 Is there a grab bar at least 36 inches long on the rear wall?</p> <p>Does it extend at least 12 inches from the centerline of the water closet on one side (side wall)?</p> <p>Does it extend at least 24 inches on the other (open) side?</p> <p>Is it mounted no less than 33 inches and no greater than 36 inches above the floor to the top of the gripping surface?</p> <p>Are there at least 12 inches</p>	<p><input type="checkbox"/> Yes <input type="checkbox"/> No</p> <p>Measurement:</p> <p><input type="checkbox"/> Yes <input type="checkbox"/> No</p> <p>Measurement:</p> <p><input type="checkbox"/> Yes <input type="checkbox"/> No</p> <p>Measurement:</p> <p><input type="checkbox"/> Yes <input type="checkbox"/> No</p> <p><input type="checkbox"/> Yes <input type="checkbox"/> No</p>		<p>Photo #:</p>	<ul style="list-style-type: none"> • Install grab bar • Relocate grab bar • Relocate objects •

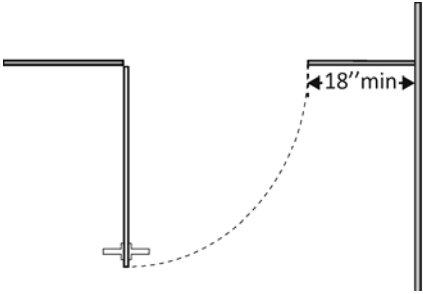
<p>clearance between the grab bar and protruding objects above?*</p> <p>Are there at least 1½ inches clearance between the grab bar and projecting objects below?*</p> <p>Is the space between the wall and the grab bar 1 ½ inches?</p>	<p>Measurement:</p> <p><input type="checkbox"/> Yes <input type="checkbox"/> No</p> <p>Measurement:</p> <p><input type="checkbox"/> Yes <input type="checkbox"/> No</p> <p>Measurement:</p>		<p>Photo #:</p>	<p>* If constructed before 3/15/2012 grab bars do not need to be relocated; there are no space requirements above and below grab bars in the 1991 Standards</p>
<p>3.35 If the flush control is hand operated, is the operable part located no higher than 48 inches above the floor?</p>	<p><input type="checkbox"/> Yes <input type="checkbox"/> No</p> <p>Measurement:</p>		<p>Photo #:</p>	<ul style="list-style-type: none"> • Move control • Install sensor with override button no higher than 48 inches •
<p>3.36 If the flush control is hand operated, can it be operated with one hand and without tight grasping, pinching, or twisting of the wrist?</p> <p>Is the force required to activate the flush control no greater than 5 pounds?</p>	<p><input type="checkbox"/> Yes <input type="checkbox"/> No</p> <p><input type="checkbox"/> Yes <input type="checkbox"/> No</p> <p>Measurement:</p>		<p>Photo #:</p>	<ul style="list-style-type: none"> • Change control • Adjust control •

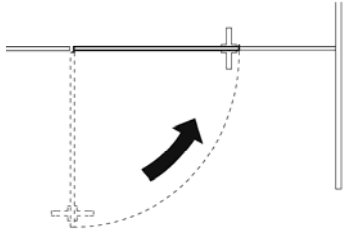
<p>3.37 Is the flush control on the open side of the water closet?</p>	<p><input type="checkbox"/> Yes <input type="checkbox"/> No</p>		<p>Photo #:</p>	<ul style="list-style-type: none"> • Move control • •
<p>3.38 Is the toilet paper dispenser located no less than 7 inches and no greater than 9 inches from the front of the water closet to the centerline of the dispenser?*</p>	<p><input type="checkbox"/> Yes <input type="checkbox"/> No</p> <p>Measurement:</p>		<p>Photo #:</p>	<p>* If constructed before 3/15/2012 dispenser does not need to be relocated if it is within reach from the water closet seat; the 1991 Standards do not specify distance from the front of the water closet</p> <ul style="list-style-type: none"> • Relocate dispenser • •
<p>3.39 Is the outlet of the dispenser:</p> <p>Located no less than 15 inches and no greater than 48 inches above the floor?</p> <p>Not located behind grab bars?</p>	<p><input type="checkbox"/> Yes <input type="checkbox"/> No</p> <p>Measurement:</p> <p><input type="checkbox"/> Yes <input type="checkbox"/> No</p>		<p>Photo #:</p>	<ul style="list-style-type: none"> • Relocate dispenser • •



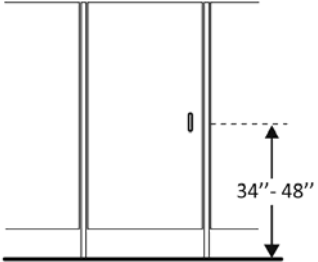
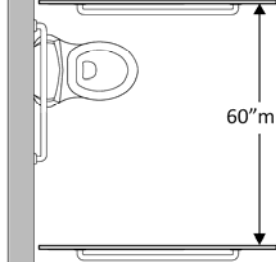
<p>3.40 Does the dispenser allow continuous paper flow?</p>	<p><input type="checkbox"/> Yes <input type="checkbox"/> No</p>		<p>Photo #:</p>	<ul style="list-style-type: none"> • Adjust dispenser • Replace dispenser •
--	---	---	-----------------	--

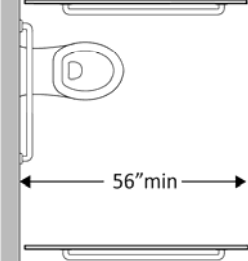
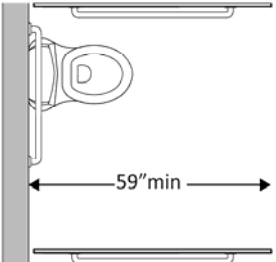
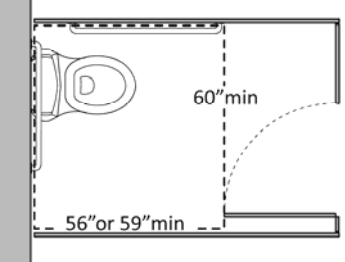
Toilet Compartments (Stalls) (2010 Standards – 604)

<p>3.41 Is the door opening width at least 32 inches clear, between the face of the door and the stop, when the door is open 90 degrees?</p>	<p><input type="checkbox"/> Yes <input type="checkbox"/> No</p> <p>Measurement:</p>		<p>Photo #:</p>	<ul style="list-style-type: none"> • Widen door width • •
---	---	--	-----------------	--

<p>3.42 If there is a front approach to the pull side of the door, is there at least 18 inches of maneuvering clearance beyond the latch side plus 60 inches clear depth?*</p>	<p><input type="checkbox"/> Yes <input type="checkbox"/> No</p> <p>Measurement:</p>		<p>Photo #:</p>	<p>*See 2010 Standards 604.8.1.2 Doors for maneuvering clearance requirements on the push side of the door and side approaches to the pull side of the door</p> <ul style="list-style-type: none"> • Remove obstructions •
---	---	---	-----------------	--

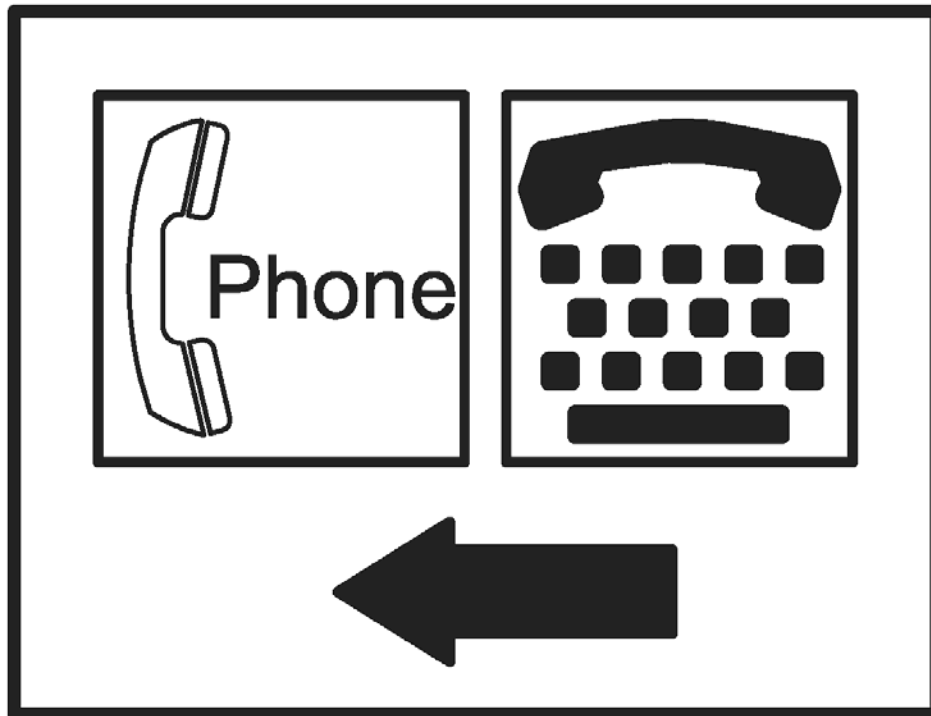
<p>3.43 Is the door self-closing?</p>	<p><input type="checkbox"/> Yes <input type="checkbox"/> No</p>		<p>Photo #:</p>	<ul style="list-style-type: none"> • Add closer • Replace door •
--	---	--	-----------------	---

<p>3.44 Are there door pulls on both sides of the door that are operable with one hand and do not require tight grasping pinching or twisting of the wrist?*</p>	<p><input type="checkbox"/> Yes <input type="checkbox"/> No</p>		<p>Photo #:</p>	<p>* If constructed before 3/15/2012 door pulls do not need to be added; door pulls are not required in the 1991 Standards</p> <ul style="list-style-type: none"> • Replace hardware • •
<p>3.45 Is the lock operable with one hand and without tight grasping, pinching or twisting of the wrist?</p>	<p><input type="checkbox"/> Yes <input type="checkbox"/> No</p>		<p>Photo #:</p>	<ul style="list-style-type: none"> • Replace lock • •
<p>3.46 Are the operable parts of the door hardware mounted no less than 34 inches and no greater than 48 inches above the floor?</p>	<p><input type="checkbox"/> Yes <input type="checkbox"/> No</p> <p>Measurement:</p>		<p>Photo #:</p>	<ul style="list-style-type: none"> • Relocate hardware • •
<p>3.47 Is the compartment at least 60 inches wide?</p>	<p><input type="checkbox"/> Yes <input type="checkbox"/> No</p> <p>Measurement:</p>		<p>Photo #:</p>	<ul style="list-style-type: none"> • Widen compartment • •

<p>3.48 If the water closet is wall hung, is the compartment at least 56 inches deep?</p>	<p><input type="checkbox"/> Yes <input type="checkbox"/> No</p> <p>Measurement:</p>		<p>Photo #:</p>	<ul style="list-style-type: none"> • Widen compartment • •
<p>3.49 If the water closet is floor mounted, is the compartment at least 59 inches deep?</p>	<p><input type="checkbox"/> Yes <input type="checkbox"/> No</p> <p>Measurement:</p>		<p>Photo #:</p>	<ul style="list-style-type: none"> • Alter compartment • •
<p>3.50 If the door swings in, is the minimum required compartment area provided beyond the swing of the door (60 inches x 56 inches if water closet is wall hung or 59 inches if water closet is floor mounted)?</p>	<p><input type="checkbox"/> Yes <input type="checkbox"/> No</p> <p>Measurement:</p>		<p>Photo #:</p>	<ul style="list-style-type: none"> • Reverse door swing • Alter compartment •
	<p><input type="checkbox"/> Yes <input type="checkbox"/> No</p>		<p>Photo #:</p>	<ul style="list-style-type: none"> • • •
	<p><input type="checkbox"/> Yes <input type="checkbox"/> No</p>		<p>Photo #:</p>	<ul style="list-style-type: none"> • • •

ADA Checklist for Readily Achievable Barrier Removal

Priority 4 – Additional Access



Project

Building

Location

Date

Surveyors

Contact Information

Amenities such as drinking fountains and public telephones should be accessible to people with disabilities.



Institute for Human Centered Design
www.HumanCenteredDesign.org
November 2011

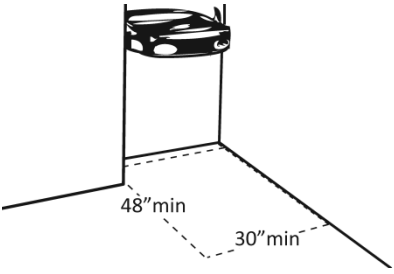
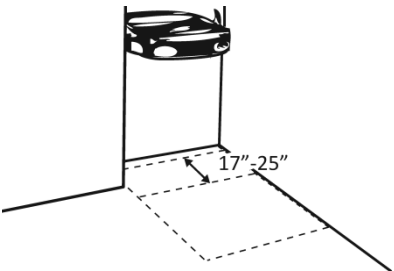
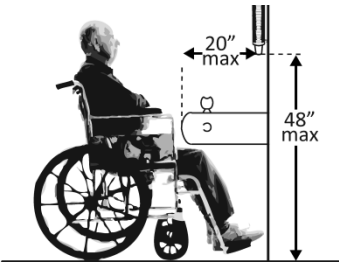


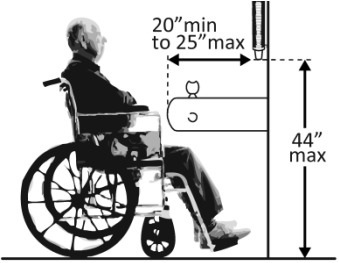

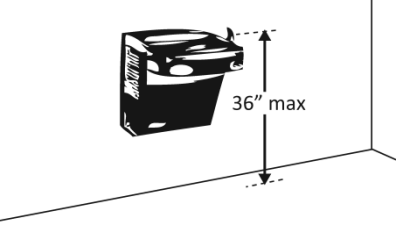
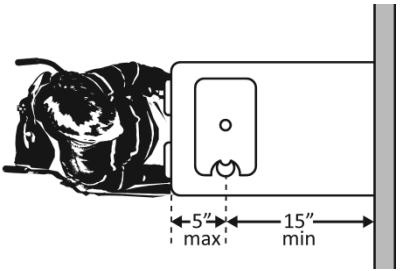
ADA National Network
Questions on the ADA 800-949-4232 voice/tty
www.ADAchecklist.org

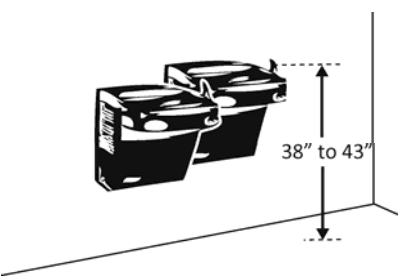
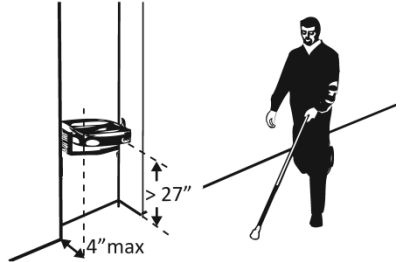
This checklist was produced by the New England ADA Center, a project of the Institute for Human Centered Design and a member of the ADA National Network. This checklist was developed under a grant from the Department of Education, NIDRR grant number H133A060092-09A. However the contents do not necessarily represent the policy of the Department of Education, and you should not assume endorsement by the Federal Government.

Questions or comments on the checklist contact the New England ADA Center at 617-695-0085 voice/tty or ADAinfo@NewEnglandADA.org

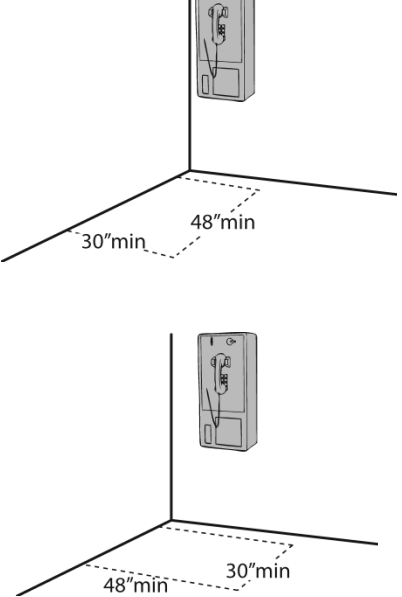
For the full set of checklists, including the checklists for recreation facilities visit www.ADAchecklist.org.

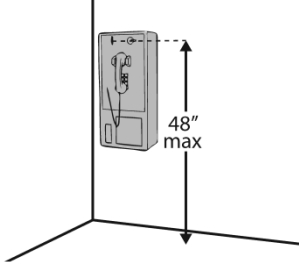
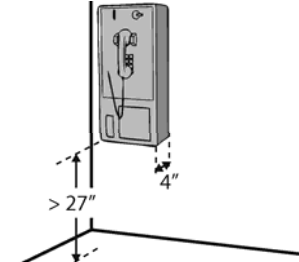


Priority 4 – Additional Access		Comments	Possible Solutions
Drinking Fountains (2010 Standards – 602)			
<p>4.1 Does at least one drinking fountain have a clear floor space at least 30 inches wide x at least 48 inches long centered in front of it for a forward approach?*</p>	<input type="checkbox"/> Yes <input type="checkbox"/> No Measurement:		<p>Photo #:</p> <p>*If installed before 3/15/2012, a parallel approach is permitted and the clear floor space is not required to be centered</p> <ul style="list-style-type: none"> • Alter space • Relocate drinking fountain • Install a drinking fountain in another location
<p>4.2 If there is a forward approach, do no less than 17 inches and no greater than 25 inches of the clear floor space extend under the drinking fountain?</p>	<input type="checkbox"/> Yes <input type="checkbox"/> No Measurement:		<p>Photo #:</p> <ul style="list-style-type: none"> • Alter space • Replace drinking fountain •
<p>4.3 If the drinking fountain is no deeper than 20 inches, are the operable parts no higher than 48 inches above the floor?</p>	<input type="checkbox"/> Yes <input type="checkbox"/> No Measurement:		<p>Photo #:</p> <ul style="list-style-type: none"> • Adjust drinking fountain • Replace drinking fountain •




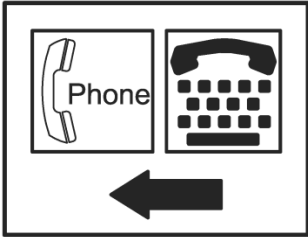
<p>4.4 If the drinking fountain is no less than 20 inches and no greater than 25 inches deep, are the operable parts no higher than 44 inches above the floor?</p>	<p><input type="checkbox"/> Yes <input type="checkbox"/> No</p> <p>Measurement:</p>		<p>Photo #:</p>	<ul style="list-style-type: none"> • Adjust drinking fountain • Replace drinking fountain •
<p>4.5 Can the control be operated with one hand and without tight grasping, pinching or twisting of the wrist?</p> <p>Is the force required to activate the control no more than 5 pounds?</p>	<p><input type="checkbox"/> Yes <input type="checkbox"/> No</p> <p><input type="checkbox"/> Yes <input type="checkbox"/> No</p> <p>Measurement:</p>		<p>Photo #:</p>	<ul style="list-style-type: none"> • Change control • Adjust control •
<p>4.6 Is the spout outlet no higher than 36 inches above the floor?</p>	<p><input type="checkbox"/> Yes <input type="checkbox"/> No</p> <p>Measurement:</p>		<p>Photo #:</p>	<ul style="list-style-type: none"> • Adjust drinking fountain • Replace drinking fountain •
<p>4.7 Is the spout:</p> <p>At least 15 inches from the rear of the drinking fountain?</p> <p>No more than 5 inches from the front of the drinking fountain?</p>	<p><input type="checkbox"/> Yes <input type="checkbox"/> No</p> <p>Measurement:</p> <p><input type="checkbox"/> Yes <input type="checkbox"/> No</p> <p>Measurement:</p>		<p>Photo #:</p>	<ul style="list-style-type: none"> • Adjust spout • Replace drinking fountain •

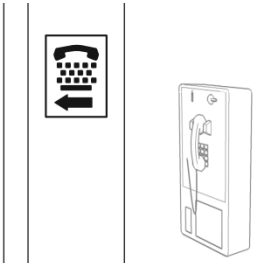

<p>4.8 If there is more than one drinking fountain, is there at least one for standing persons?</p> <p>Is the spout outlet no lower than 38 inches and no higher than 43 inches above the floor?</p>	<p><input type="checkbox"/> Yes <input type="checkbox"/> No</p> <p><input type="checkbox"/> Yes <input type="checkbox"/> No</p> <p>Measurement:</p>		<p>Photo #:</p>	<ul style="list-style-type: none"> • Adjust drinking fountain • Install new drinking fountain for standing height •
<p>4.9 If the leading (bottom) edge of the fountain is higher than 27 inches above the floor, does the front of the fountain protrude no more than 4 inches into the circulation path?</p>	<p><input type="checkbox"/> Yes <input type="checkbox"/> No</p> <p>Measurement:</p>		<p>Photo #:</p>	<ul style="list-style-type: none"> • Adjust drinking fountain • Replace drinking fountain • Add tactile warning such as permanent planter or partial walls

Public Telephones (2010 Standards – 704) TTY's are devices that employ interactive text-based communication through the transmission of coded signals across the telephone network. They are mainly used by people who are deaf and/or cannot speak.

<p>4.10 Does at least one telephone have a clear floor space at least 30 inches wide x at least 48 inches long for a parallel or forward approach?</p>	<p><input type="checkbox"/> Yes <input type="checkbox"/> No</p>		<p>Photo #:</p>	<ul style="list-style-type: none"> • Move telephone • Install new telephone for clear floor space •
---	---	---	-----------------	--

<p>4.11 Is the highest operable part of the telephone no higher than 48 inches above the floor?</p>	<p><input type="checkbox"/> Yes <input type="checkbox"/> No</p> <p>Measurement:</p>		<p>Photo #:</p>	<ul style="list-style-type: none"> • Adjust telephone • •
<p>4.12 If the leading (bottom) edge of the telephone is higher than 27 inches above the floor, does the front of the telephone protrude no more than 4 inches into the circulation path?</p>	<p><input type="checkbox"/> Yes <input type="checkbox"/> No</p> <p>Measurement:</p>		<p>Photo #:</p>	<ul style="list-style-type: none"> • Adjust telephone • •
<p>4.13 Does at least one telephone have a volume control?</p>	<p><input type="checkbox"/> Yes <input type="checkbox"/> No</p>		<p>Photo #:</p>	<ul style="list-style-type: none"> • Install volume control • Replace telephone with one that has volume control •
<p>4.14 Is the volume control identified by a pictogram of a telephone handset with radiating sound waves?</p>	<p><input type="checkbox"/> Yes <input type="checkbox"/> No</p>		<p>Photo #:</p>	<ul style="list-style-type: none"> • Add pictogram • •

<p>4.15 Does at least one telephone have a TTY?</p>	<p><input type="checkbox"/> Yes <input type="checkbox"/> No</p>		<p>Photo #:</p>	<ul style="list-style-type: none"> • Install TTY • •
<p>4.16 Is the touch surface of the TTY keypad at least 34 inches above the floor?</p>	<p><input type="checkbox"/> Yes <input type="checkbox"/> No</p> <p>Measurement:</p>		<p>Photo #:</p>	<ul style="list-style-type: none"> • If a seat is provided, TTY is not required to be 34 inches minimum above the floor • Adjust height of TTY •
<p>4.17 Is the TTY identified by the International Symbol of TTY?</p>	<p><input type="checkbox"/> Yes <input type="checkbox"/> No</p>		<p>Photo #:</p>	<ul style="list-style-type: none"> • Add symbol • •
<p>4.18 Do signs that provide direction to public telephones also provide direction to the TTY?</p>	<p><input type="checkbox"/> Yes <input type="checkbox"/> No</p>		<p>Photo #:</p>	<ul style="list-style-type: none"> • Add signs • •

<p>4.19 Do telephones that do not have a TTY provide direction to the TTY?</p>	<p><input type="checkbox"/> Yes <input type="checkbox"/> No</p>		<p>Photo #:</p>	<ul style="list-style-type: none"> • Add signs • •
<p>Fire Alarm Systems (2010 Standards – 702)</p>				
<p>4.20 If there are fire alarm systems, do they have both flashing lights and audible signals?</p>	<p><input type="checkbox"/> Yes <input type="checkbox"/> No</p>		<p>Photo #:</p>	<ul style="list-style-type: none"> • Install audible and visual alarms • •
	<p><input type="checkbox"/> Yes <input type="checkbox"/> No</p>		<p>Photo #:</p>	<ul style="list-style-type: none"> • • •
	<p><input type="checkbox"/> Yes <input type="checkbox"/> No</p>		<p>Photo #:</p>	<ul style="list-style-type: none"> • • •
	<p><input type="checkbox"/> Yes <input type="checkbox"/> No</p>		<p>Photo #:</p>	<ul style="list-style-type: none"> • • •

Ambulatory Stall Checklist

Ambulatory stall is required if total combination of toilets and urinals in restroom is 6 or more

Standard #	Item	Questions/Items to Review	Yes	No	Measurement	Notes
604.8.2.1	Size	Diagram space if answers are no				
		Is the stall at least 60" deep?				
		Is the stall between 35" and 37" wide (wall to wall)?				
604.8.2.2	Door					
		If provided, does the door:				
		Have clear width at least 32"?				
		Does it swing outward?				Must not encroach req'd space
		For parallel latch approach is there at least 24"x42" clear space on the pull side?				24" is beyond edge of door on latch side
		For parallel hinge approach is there at least 42"x54" clear space on the pull side?				42" is beyond edge of door on latch side
		Is all hardware located between 34" and 48" high?				
		Is all hardware operable with one hand without tight grasping, gripping, or twisting of the wrist?				
		Are there pull hooks on both sides of door?				
		Can it be opened with less than 5 pounds of force?				
		Is it self-closing?				
604.8.2.3	Grab Bars					
		Is there a grab bar on both sides of the stall?				
		Are the grab bars between 1.25" and 2" in diameter?				If non-circular, measure dimensions
		Are the grab bars 1.5" from the wall?				
		Is the gripping surface between 33" and 36" from the floor?				
		Are the bars at least 42" long?				
		Are the bars located a maximum of 12" from rear wall?				
		Do the bars extend a minimum of 54" from rear wall?				

Jail Cell Checklist

232.2.1 - At least 2 percent, but no fewer than one, of the total number of cells in a facility should meet the mobility requirements below, and at least one of each type.

Standard #	Item	Questions/Items to Review	Yes	No	Measurement	Notes
807.2.1	Turning Space					Diagram space if answers are no
		Is the ground surface level?				
		Is the space 60" in diameter?				Can include knee clearances
		Is the space a "T" in a 60" square with arms <36" wide?				Knee clearance allowed on one arm
807.2.2	Benches					
		If provided, does at least one bench:				
		Have 30"x48" clear space next to it?				Parallel to short axis
		Is it at least 42" long and between 20" and 24" deep?				
		Is there back support?				If no, skip next 3 items
		Is the back support at least 42" long?				
		Does it extend from max. 2" above to min. 18" above the seat?				
		Is it located a max. of 2.5" horizontally from the rear of the seat?				
		Is the top of the bench seat 17" to 19" from the floor?				
807.2.3	Beds					
		Is there a 30"x48" parallel approach?				
807.2.4	Toilet and Bathing Facilities					Separate room not required, must comply with 603 to 610
		1. Use Toilet Room Checklist from New England ADA Center for toilet, sink, and miscellaneous items, may require diagram of entire cell				
		2. Measure and diagram all elements of bath or shower and their location compared to other elements in cell to review with 607 to 610, all seats/controls/clear spaces/grab bars, shower hose >59"				
807.3.1	Alarms					
		If audible alarm is provided, is it visual as well?				
807.3.2	Telephones					
		If a phone is provided, does it contain volume controls?				

Passenger Loading Zone Checklist

Standard #	Item	Questions/Items to Review	Yes	No	Measurement	Notes
503.2	Vehicle Pull-Up Space					
		Is the pull up space at least 96" wide by 20' long?				
503.3	Access Aisle					
		Is the access aisle at least 60" wide?				
		Does the access aisle extend the full length of the pull up space?				
		Is the access aisle marked to discourage parking within?				
503.4	Floor and Ground					
		Does the surface have slope less than 2% in all directions?				Space and aisle
503.5	Vertical Clearance					
		Is at least 114" of vertical clearance provided?				Includes route to space

Stairs Checklist

Interior and exterior stairs that are a part of a means of egress shall comply with 504

Standard #	Item	Questions/Items to Review	Yes	No	Measurement	Notes
504.2	Treads and Risers					
		Do the steps have uniform heights and depths?				
		Are the risers between 4" and 7" high?				
		Are the treads at least 11" deep?				
		Open risers are not permitted				
504.4	Tread Surface					
		Are the treads firm, stable, and slip resistant?				
		Do the treads have slope less than 2%?				
		Are the treads designed to prevent the accumulation of water?				
504.5	Nosings					
		Is the radius of curvature at the leading edge 0.5" maximum?				
		If the nosing project from the riser, is the underside of the leading edge curved or beveled?				
		Does the riser slope no more than 30 degrees from vertical under the tread?				
		Does the nosing extend no more than 1.5" over the tread below?				
504.6	Handrails					
		Are handrails located on both sides?				
		Do the handrails run continuously the full length of each flight?				
		Does the inside rail run continuously between flights?				
		Is the gripping surface between 34" and 38" from the ground?				Measured at stair nosing
		Is the handrail a minimum 1.5" from the wall?				
		Is the bottom of the handrail gripping surface obstructed for no more than 20 percent of the length?				
		Are horizontal projections at least 1.5" below the bottom of the handrail?				
		Is the railing between 1.25" and 2" in diameter?				If non-circular, measure dimensions
		Do handrails extend at least 12" horizontally above top landing?				Excluding continuous handrails
		Do handrails extend one tread length beyond last riser nosing at the slope of the stair flight at the bottom landing?				
		Do handrails return to a wall, guard, or landing surface, or extend continuously to an adjacent stair flight?				

APPENDIX H
CURB RAMPS AND PEDESTRIAN CROSSINGS CHECKLISTS

Chapter 6 Addendum: Title II Checklist (Curb Ramps and Pedestrian Crossings)

PURPOSE OF THIS CHECKLIST: This checklist is designed to help you **conduct a preliminary assessment to determine if your entity is in compliance with the requirements for curb ramps at pedestrian crossings under Title II of the ADA.** By using the checklist, you can determine if there are any red flags indicating that your entity may not be in compliance with Title II requirements. It also outlines steps you can take to come into compliance with Title II requirements for providing curb ramps at pedestrian crossings if you identify compliance problems.

MATERIALS AND INFORMATION NEEDED: To determine if your entity is in compliance with the ADA requirements for curb ramps at pedestrian crossings, you will need:

- ✓ The written policies and procedures and the contracts and specifications that your government entity has used since January 26, 1992, relating to the construction, alteration, and repair of highways, streets, roads, sidewalks, pedestrian crossings, and curb ramps.
- ✓ Your entity's long-range plan for the construction, alteration, and/or repair of highways, roads, streets, sidewalks, pedestrian crossings, and curb ramps.
- ✓ The written procedures your entity uses to evaluate requests for installation of, or modifications to, curb ramps.
- ✓ Any standard curb ramp designs and specifications that your entity, or contractors working for your entity, have used since January 26, 1992.
- ✓ Written policies and procedures your entity uses to ensure that the accessibility of curb ramps at pedestrian crossings is maintained.
- ✓ A list of the pedestrian crossings constructed by or on behalf of your entity since January 26, 1992. To assist you in identifying systemic problems, it would be helpful for you to know, for each of these pedestrian crossings, the date when construction commenced, the name of the firm or individual

that designed the pedestrian crossing, and the name of the contractor who did the construction.

- ✓ A list of the pedestrian crossings altered by or on behalf of your entity since January 26, 1992. Pedestrian walkways and roadways should generally be considered altered if they have been resurfaced since January 26, 1992. Curb ramps adjacent to those pedestrian walkways and roadways should also be considered altered. Filling a pothole should not be considered an alteration. For each of the pedestrian crossings that were altered, to assist you in identifying systemic problems, it would be helpful for you to know the date when the alteration occurred, the name of the firm or individual that performed design work, if any, for the alteration and the name of the contractor who performed the alterations.
- ✓ Copies of the Curb Ramps survey instructions and form that will be released in the next installment of this Tool Kit for yourself and everyone who will assist you in surveying your entity's curb ramps. You will also need survey tools for each survey team, including a metal measuring tape, a level, and a camera. A clipboard to hold survey forms can also be helpful.
- ✓ Copies of any feedback received from people with disabilities about the accessibility of your pedestrian crossings.

You may need the assistance of personnel responsible for overseeing highway, street, road, and sidewalk maintenance to assist you in completing the checklist.

Evaluating Compliance with the Requirements for Curbs at Pedestrian Crossings

Review the policies, procedures, and contracts your entity has used relating to the construction, alteration, and repair of curb ramps. If your entity does not have written policies and procedures, you will need to interview the appropriate employees to find out what policies and procedures your entity has followed.

1. Since January 26, 1992, has your entity implemented policies and procedures to ensure that curb ramps or other sloped surfaces were provided wherever walkways intersected curbs whenever your entity constructed or altered highways, streets, roads, pedestrian crossings (including traffic islands), and sidewalks? (For purposes of answering this checklist, alteration generally includes paving, repaving, and resurfacing but does not include normal maintenance, such as filling potholes.)

- Yes
- No

2. Since January 26, 1992, has your entity implemented policies and procedures to ensure that curb ramps at pedestrian crossings were constructed and altered in compliance with either the ADA Standards for Accessible Design or the Uniform Federal Accessibility Standards?

- Yes
- No

3. Review any standardized curb ramp designs and specifications that your entity has used since January 26, 1992. To determine compliance, use the requirements outlined in Chapter 6 of this Tool Kit. Are the designs ADA-compliant? (If you do not have experience reviewing design and specification documents, you may find it helpful to obtain assistance from personnel who work in your highway or public works department.)

- Yes
- No

4. Survey a sample of the pedestrian crossings on portions of highways, streets, and roads that were constructed by or on behalf of your entity after January 26, 1992, and a sample of the curb ramps at pedestrian crossings on portions of highways, streets, and roads that were altered after January 26, 1992. In selecting your samples, make sure that you have a representative selection of pedestrian crossings constructed and altered at different time periods between January 26, 1992, and the present as well as curb ramps constructed and altered by a variety of different contractors and located in different areas of your community. To conduct the surveys, use the Curb Ramps survey instructions and Curb Ramps survey form that will be released in the next installment of this Tool Kit.
- a. Do all curbs where sidewalks and walkways intersect with roads, streets, or highways have curb ramps that allow people with disabilities to go from the sidewalk on one side of the vehicular way across any traffic islands with curbs to the sidewalk on the opposite side?
- Yes
 No
- b. Are all of these curb ramps free of accessibility problems (which would only be the case if you answer “Y” or “n/a” to all the questions on the Curb Ramps survey form when you conduct your survey)?
- Yes
 No
5. Has your entity performed an evaluation of its **pre-ADA** pedestrian crossings to identify the locations where curb ramps need to be constructed to provide **program access** for people with disabilities? (This survey may have occurred when your entity performed a self-evaluation and developed a transition plan.)
- Yes
 No

6. If the answer to Question #5 is “Yes,” has your entity been implementing those curb ramp installations as it implements its long-range plan for streets and sidewalks?
- Yes
 - No
 - N/A
7. Does your entity seek input from people with disabilities with respect to its plans for the construction and alteration of highways, streets, roads, sidewalks, and pedestrian crossings?
- Yes
 - No
8. Does your entity have a mechanism that people with disabilities can use to request the installation or repair of a curb ramp?
- Yes
 - No
9. If your answer to Question #8 is “Yes,” does your entity also have procedures to ensure that such requests are given priority when your entity plans and implements the construction and alteration of streets, roads, highways, sidewalks, and pedestrian crossings?
- Yes
 - No
 - N/A

ACTIONS:

If you answered “No” to any of these questions, it is likely that your entity needs to take some steps to comply with the ADA requirements for curb ramps at pedestrian crossings. The steps needed will depend on whether the problems identified relate to new construction, alterations, the accessibility of pre-ADA pedestrian crossings, or the maintenance of accessibility.

- ✓ Identify the newly constructed and altered pedestrian crossings that are inaccessible and incorporate them into your entity's long-range plan for streets and sidewalks.
- ✓ Implement written policies and procedures to ensure that newly constructed and altered pedestrian crossings are accessible from this point forward.
- ✓ Implement written policies and procedures to ensure that, whenever streets, roads, and highways are altered or resurfaced, curb ramps are installed at pedestrian crossings.
- ✓ Review any standardized designs your entity uses for the construction of curb ramps and change them, if necessary, to comply with ADA requirements.
- ✓ Assess the extent to which your entity has complied with ADA requirements for providing curb ramps at pedestrian crossings and transportation stops. To survey curb ramps in your community, use the Curb Ramps survey form and instructions that will be released in the next installment of this Tool Kit.
- ✓ Evaluate the accessibility of your **pre-ADA** pedestrian crossings and, using the results of that evaluation, develop a long-range plan to improve their accessibility. In formulating your long-range plan, give priority to accessibility modifications in the following order: those serving or in close proximity to local government facilities, bus stops and other transportation services, public accommodations, business districts, and residential areas where requests for curb ramps or other accessibility modifications have been made.
- ✓ Get input from people with disabilities on your long-range plan for improving the accessibility of pedestrian crossings.
- ✓ Make sure that requests by people with disabilities for the installation and repair of curb ramps are incorporated into your long-range action plan for improving the accessibility of pedestrian crossings. Such requests can help you identify locations that pose access problems for people with disabilities.
- ✓ Finally, as part of your review of your state or local government's

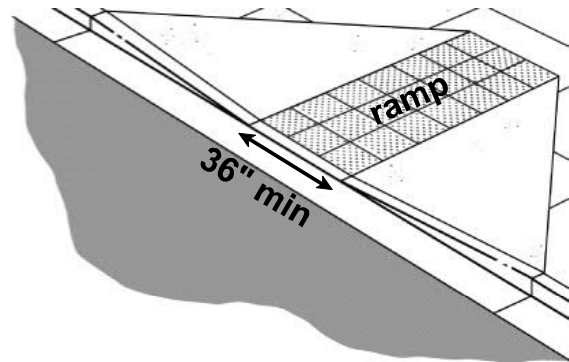
buildings and programs, don't forget to look at the pedestrian routes from accessible parking spaces and transportation stops to the accessible entrances to your facilities. Determine where curb ramps need to be installed. Include these curb ramps as a top priority in your long-range action plan to improve the accessibility of pedestrian crossings.

ADA Accessibility Survey Instructions: Curb Ramps

1

[§ 4.7.3]

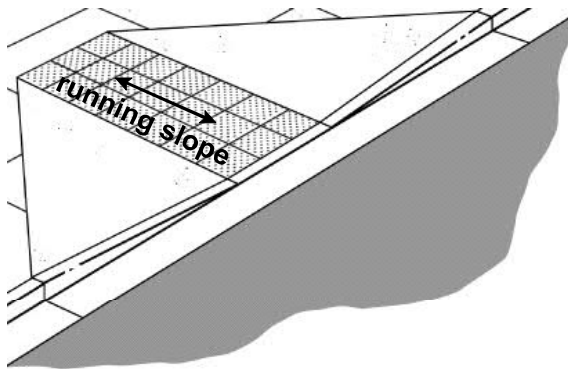
Only measure the width of the ramp section of the curb ramp (labeled “ramp” to the right). The ramp section of a curb ramp is also known as the “ramp run.” If the curb ramp has flared sides, which can also be seen in the illustration to the right, do not include them in the measurement. The ramp run must be at least 36 inches wide.



2

[§§ 4.7.2; 4.8.2; 4.1.6(3)(a)]

The running slope of the curb ramp is the slope in the direction that people travel when going up or down the ramp run. The arrow in the illustration to the left, aligned parallel to the ramp run and perpendicular to the curb, shows where to measure the running slope.

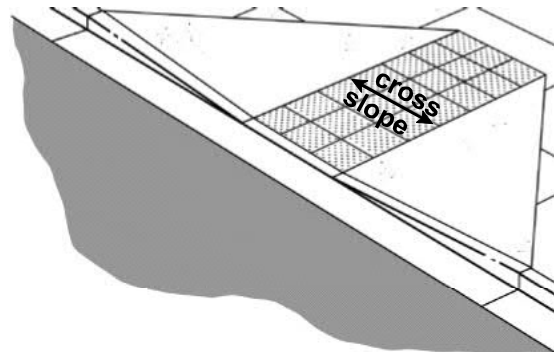


For new construction (when the curb ramp was built after January 26, 1991), the running slope of the ramp run must not exceed 8.33 percent. For alterations (when the curb ramp was altered after January 26, 1991), the slope must not exceed 10 percent for a 6-inch rise or 12.5 percent for a 3-inch rise.

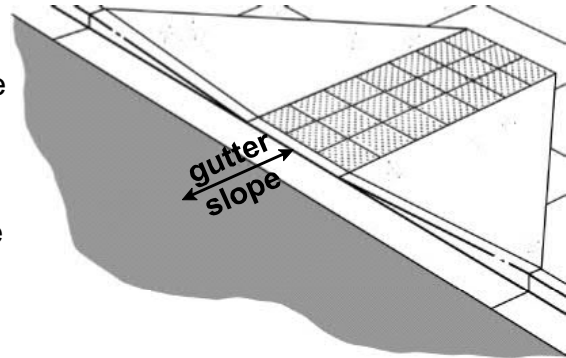
3

[§ 4.3.7]

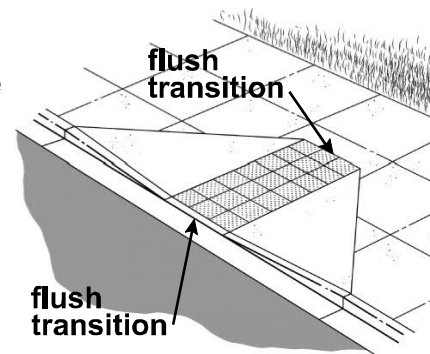
The cross slope of the curb ramp is perpendicular to the running slope. Unlike the running slope, which runs along the ramp, the cross slope is measured *across* the ramp. The arrow in the illustration to the right, aligned perpendicular to the ramp run and parallel to the curb, shows where to measure the cross slope. The cross slope of a curb ramp, or any accessible route, may not exceed 2 percent.



The gutter is the part of the street that borders the curb. To measure the gutter slope, place the level in the same position as the arrow in the illustration, with one end where the gutter meets the ramp and the other end towards the street. The gutter slope is parallel to the ramp and perpendicular to the curb. The gutter may slope up to 5 percent towards the curb ramp, but not more.



The transitions on and off the curb ramp are the points where the gutter meets the bottom of the ramp and where the top of the ramp meets the sidewalk. These transition points are required to be flush and cannot have any abrupt level changes. Record any level change at the transitions.

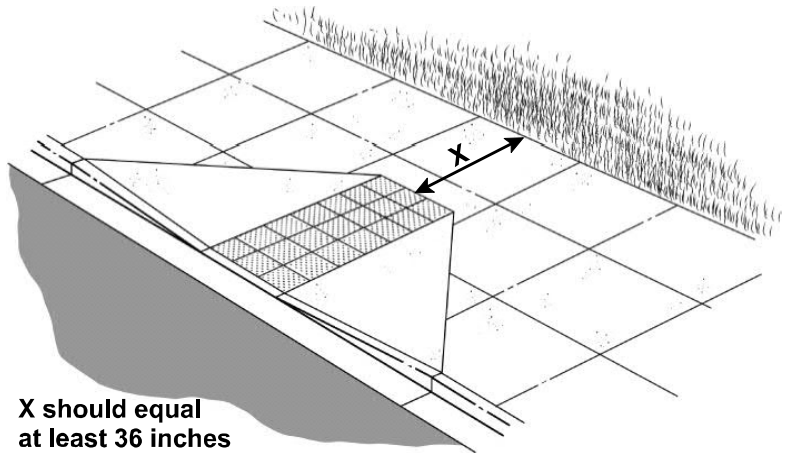


Detectable warnings are dome-shaped bumps that should cover the entire width and depth of the ramp run. Detectable warnings are designed to be felt underfoot or with a cane by people who are blind or have low vision, thereby alerting them of hazards – mainly, the transition from a pedestrian-only area to a roadway.

If the curb ramp you are surveying has detectable warnings but they do not cover the entire ramp run, explain how they are different in the “Comments” section at the bottom of the form. For curb ramps along public streets, the U.S. Department of Transportation (DOT) has deemed permissible a strip of detectable warnings that stretches across the width of the ramp run but covers only the two feet nearest the road. If the curb ramp you are surveying is located along a public street, you may circle "Y" if the detectable warnings comply with the DOT's design.

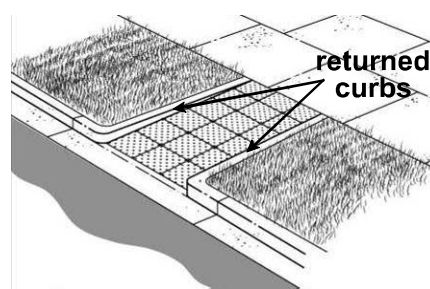
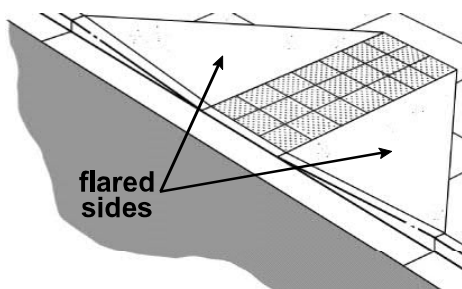
Curb ramps must be located where they will not be obstructed by parked vehicles. If the curb ramp you are surveying is along a public right-of-way or at a pedestrian crossing, vehicles should be prohibited from parking directly in front of the curb ramp on the street. If the curb ramp you are surveying is part of the accessible route from a parking lot to a building, the curb ramp may not lead into a parking space because the curb ramp will be obstructed when a vehicle parks in the space.

Curb ramps should have at least 36 inches of clear space at the “top” of the ramp, which can be seen in the illustration to the right. The 36-inch space at the top of the ramp allows pedestrians who are continuing along the sidewalk to bypass the curb ramp without traveling over it.



The measurement should extend from where the ramp run meets the level sidewalk (at the lower end of the arrow) to the opposite edge of the sidewalk (where the sidewalk meets the grass). Do not include any part of the curb ramp in this measurement.

Curb ramps either have flared sides or vertical edges called returned curbs. Using the illustrations below, determine whether the curb ramp you are surveying has flared sides or returned curbs and answer accordingly. The next two questions relate to the slope of flared sides, and you should answer them only if you determine your curb ramp has flared sides. If your curb ramp has returned curbs, skip to question 10.

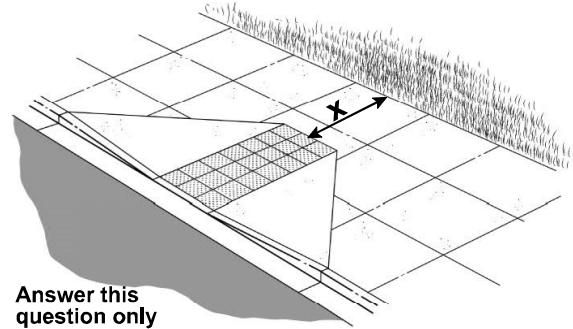


9.a

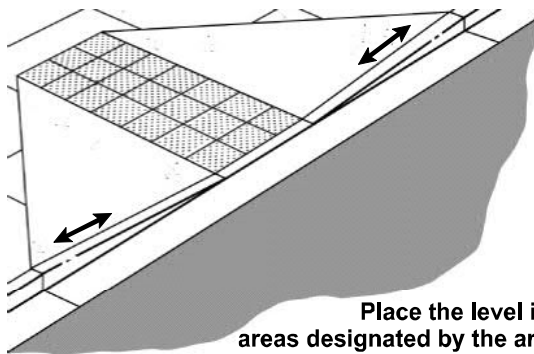
[§ 4.7.5]

If the sidewalk at the top of the ramp (“x” in the illustration) is 48 inches wide or more, answer this question. If “x” is less than 48 inches, skip this question and answer the next one.

To answer this question you need to determine the slope of the flared sides to make sure it is 10 percent or less.



Answer this question only if X = 48" or more



Place the level in the areas designated by the arrows to measure the slope of the flared sides

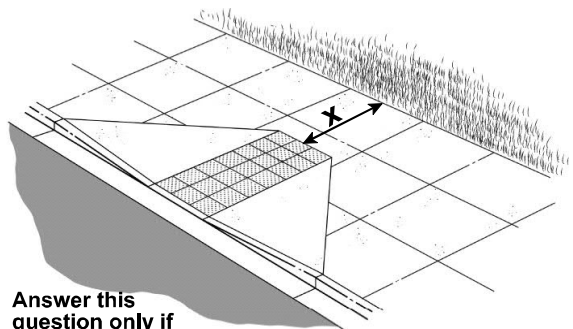
To measure the slope of a curb ramp’s flared side, place a level on the flared side near the edge of the curb. The level should be placed so that it is parallel to the curb. Place the level in the same position and location as each of the arrows in the illustration to the left.

9.b

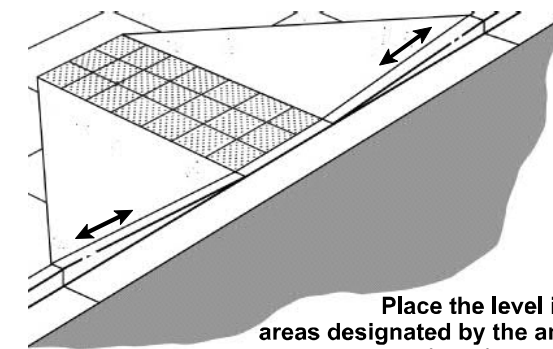
[§ 4.7.5]

If the sidewalk at the top of the ramp (“x”) is less than 48 inches wide and the curb ramp you are surveying has flared sides, answer this question. Otherwise, skip this question.

To measure the slope of the curb ramp’s flared side, place a level on the flared side near the edge of the curb. The level should be placed so that it is parallel to the curb.



Answer this question only if X is less than 48"

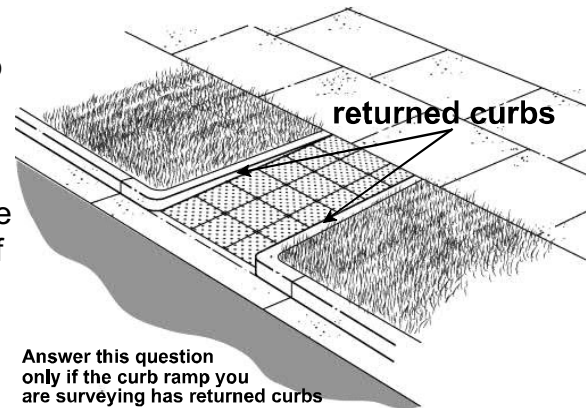


Place the level in the areas designated by the arrows to measure the slope of the flared sides

Place the level in the same position and location as each of the arrows in the illustration to the left. The slope of the curb ramp’s flared sides may not exceed 8.33 percent when there is less than 48 inches between the top of the curb ramp and the edge of the sidewalk at the other side (“x”).

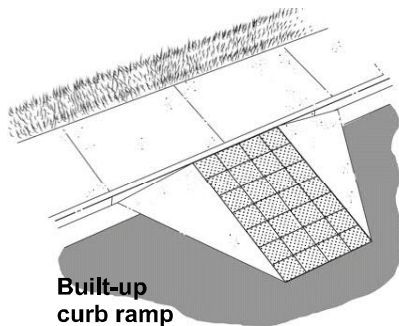
Answer this question only if you skipped the previous two questions because the curb ramp you are surveying does not have flared sides.

Curb ramps must have flared sides unless pedestrians would not normally walk across the ramp. A curb ramp may have returned curbs if it has non-walking surfaces (such as grass) or obstructions on both sides because these conditions would normally discourage pedestrians from walking across the ramp.



Generally, an object will qualify as an obstruction if it is immovable and is large enough to make it unlikely that pedestrians will walk across the ramp.

A built-up curb ramp typically consists of asphalt or concrete that is poured and shaped into a ramp that runs at a 90-degree angle away from an intact curb down to the roadway.

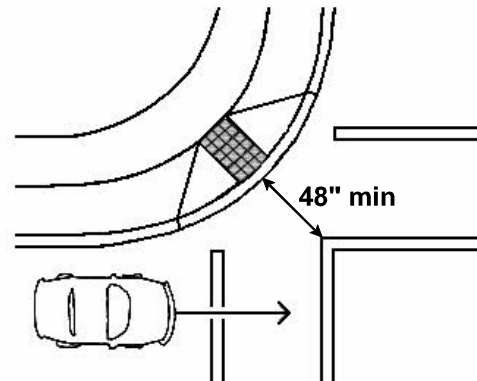


Built-up curb ramps cannot project into the path of cars. The “path of cars” includes anywhere cars are allowed to drive, including roadways, parking lot driveways, parking spaces, and access aisles.

Built-up curb ramps should have flared sides with a slope of 10 percent or less or have edge protection and handrails on the sides.

When a curb ramp is located at a marked crossing, the area where the ramp run ends must be contained within the marked crossing. The flared sides of a curb ramp do not have to be within the marked crossing.

A corner-type curb ramp is located at the center (or apex) of a corner and is often aligned to direct users into the middle of an intersection. As the illustration on the right shows, the alignment of a corner-type curb ramp means that people who travel down the ramp might be near the path of vehicular traffic once they enter the street. Therefore, if a marked crossing or crosswalk is provided, there must be a 48-inch deep area contained within the markings at the bottom of the ramp to protect people after they descend the ramp.



When taking this measurement, the measuring tape should be aligned parallel to the ramp run itself and should stretch from the intersection of the ramp and gutter to the innermost edge of the pavement marking.

Curb Ramps

Construction/Alteration Date (circle one): Before 1/26/92 After 1/26/92

Facility Name/Address:	Date:
Location:	Surveyors:

Record your measurements in the blanks when they are provided. Do not circle a response for a question you are directed to skip. If your answer to a question is no, but the choices are "Y" and "n/a," circle "n/a" (not applicable).
A circled "N" signifies a violation.

Describe each curb ramp's location:	Curb Ramp D:
Curb Ramp A:	Curb Ramp E:
Curb Ramp B:	Curb Ramp F:
Curb Ramp C:	Curb Ramp G:

Refer to #	Curb Ramp (CR) Questions	Curb Ramp A		Curb Ramp B		Curb Ramp C		Curb Ramp D		Curb Ramp E		Curb Ramp F		Curb Ramp G	
		Y	N	Y	N	Y	N	Y	N	Y	N	Y	N	Y	N
1	Is ramp of CR at least 36" wide (not including flared sides)?														
2	Does CR have a running slope of 8.33% or less?														
3	Does CR have a cross slope of 2% or less?														
4	Does CR have a gutter slope of 5% or less?														
5	Are transitions on and off CR flush and free of abrupt level changes? <i>Record the height of any level changes.</i>														
6	Does CR have detectable warnings?														
7	Can CR be blocked by legally parked cars?														
8	Is the sidewalk at the "top" of CR at least 36" wide?														
9	Does CR have flared sides? <i>If yes, answer one of the next two questions. If not, skip to question 10.</i>		n/a		n/a		n/a		n/a		n/a		n/a		n/a
9.a	If the sidewalk at the "top" of CR is 48" wide or more, is the slope of the flared sides 10% or less?														
9.b	If the sidewalk at the "top" of CR is less than 48" wide, is the slope of the flared sides 8.33% or less?														
10	If no flared sides, is there an obstruction or grass on each side of CR that discourages pedestrians from traveling across ramp? <i>If the CR has flared sides, skip this question.</i>														
11	If CR is built-up to the curb, is it outside the path of cars? <i>If CR is not built-up to curb, skip this question.</i>														
Answer the last two questions only if the CR is located at a marked crossing:															
12	Is ramp of CR contained in markings?														
13	If corner-type CR, is bottom landing at least 48" long and contained in crosswalk? <i>If not corner-type CR, skip this question.</i>														

Comments: _____

Appendix A

Positions and Job Descriptions of those assigned to the Special Recreation Division

(Need to add Job Descriptions)

Program Supervisor (1 Full-Time)

Special Recreation Program Specialist (1 Full-Time)

Program Coordinator (2 Part-Time, 29 hours per week)

Program Assistant (1 Part-Time, 19 hours per week)

Recreation Instructor/Specialist (2 Part-Time, 19 hours per week)

Recreation Instructor II (22 Part-Time, 19 hours per week)

Recreation Instructor I (18 Part-Time, 19 hours per week)

Inclusion Aides (16 Part-Time/Seasonal, 19-35 hours per week depending on season)

Recreation Instructor II/Bus Drivers (4 Part-Time, 19 hours per week)

Day Camp Assistant Site Director (4 Part-Time/Seasonal, 19-35 hours per week, depending on season)

DRAFT

Village of Orland Park

Position Description

POSITION TITLE: Inclusion Aide (part-time)
DEPARTMENT: Recreation and Parks
CATEGORY: Paraprofessional
REPORTS TO: Special Recreation Supervisor
FLSA STATUS: Non-Exempt
PREPARED BY: Kathleen Hellwig
PREPARED DATE: December 2014



POSITION SUMMARY: This position is responsible for the assistance of individuals with special needs in recreation programs.

ESSENTIAL DUTIES AND RESPONSIBILITIES:

1. Regular and consistent attendance is required for this position.
2. Provides 1:1 support for individuals with special needs enrolled in Recreation Programs. Provides vocational, leisure and social activities for participants registered in Recreation Programs.
3. Provides assistance with activities of daily living (ADL), i.e. feeding, toileting, grooming, and dressing as needed.
4. Responsible for implementing parallel, inclusive and adaptive activities to promote optimal experience for participants with special needs.
5. Responsible for implementing redirection techniques and behavioral management skills to ensure the safety of the participant.

SUPERVISION RECEIVED: General supervision received from the Special Recreation Program Supervisor. Inclusion Aides report directly to the Inclusion Special Recreation Program Coordinator. The Special Recreation Program Coordinator reports directly to the Special Recreation Program Supervisor.

MANAGERIAL/SUPERVISORY RESPONSIBILITIES: This position has no supervisory responsibilities.

POSITION REQUIREMENTS: To perform this job successfully, an individual must be able to perform each essential duty satisfactorily. The requirements listed below are representative of the knowledge, skill, and/or ability required. Reasonable accommodations may be made to enable individuals with disabilities to perform the essential job functions.

Education: High School diploma or G.E.D. 30 hours of college credit hours in a related field is preferred.

Experience: Previous related academic, work, volunteer, or coaching experience is highly preferred. Experience working with individuals with special needs is recommended.

CERTIFICATIONS, LICENSES, REGISTRATIONS: First Aid/CPR

PHYSICAL DEMANDS: The physical demands described here are representative of those that must be met by an employee to successfully perform the essential functions of this job. Reasonable accommodations may be made to enable individuals with disabilities to perform the essential job functions.

While performing the duties of this job the employee is required to frequently walk, bend, stoop, stand, and sit. The employee is occasionally required to lift, carry, push, and pull up to twenty-five pounds, and to lift a child with assistance up to 100 pounds. They will also be required to occasionally run, kneel, twist, and squat.

WORK ENVIRONMENT: The work environment characteristics described here are representative of those an employee encounters while performing the essential functions of this job. Reasonable accommodations may be made to enable individuals with disabilities to perform the essential functions.

The work environment will vary depending on the program the Inclusion Aide is assigned to. Work may be outside in hot, warm, and cool weather; in village owned facilities, or other indoor or outdoor facilities. The work environment may be hectic, busy, and noisy depending on the program.

Nothing in this job description restricts management's right to assign or reassign duties and responsibilities to this job at any time.

Official copies maintained in Human Resources. Printed copies may be dated.

Village of Orland Park

Position Description

POSITION TITLE: Inclusion Aide/Summer Camp (part-time)
DEPARTMENT: Recreation and Parks
CATEGORY: Paraprofessional
REPORTS TO: Special Recreation Supervisor
FLSA STATUS: Non-Exempt
PREPARED BY: Kathleen Hellwig
PREPARED DATE: December 2014



POSITION SUMMARY: This position is responsible for the assistance of individuals with special needs in summer camp.

ESSENTIAL DUTIES AND RESPONSIBILITIES:

1. Regular and consistent attendance is required for this position.
2. Provides 1:1 support for individuals with special needs enrolled in Recreation Programs during the summer season, specifically summer camp.
3. Provides assistance with activities of daily living (ADL), i.e. feeding, toileting, grooming, and dressing as needed.
4. Responsible for implementing parallel, inclusive and adaptive activities to promote optimal experience for participants with special needs during summer camp.
5. Responsible for implementing redirection techniques and behavioral management skills to ensure the safety of the participant during summer camp.

SUPERVISION RECEIVED: Inclusion Aides report directly to the Inclusion Assistant Site Director for their assigned camp. The Assistant Site Director for camp reports to the Special Recreation Program Coordinators. The Special Recreation Program Coordinators report to the Special Recreation Program Supervisor. For all other inclusion aides providing services throughout the recreation department, direct supervision will be provided by the Inclusion Special Recreation Program Coordinator.

MANAGERIAL/SUPERVISORY RESPONSIBILITIES: This position has no supervisory responsibilities

POSITION REQUIREMENTS:

To perform this job successfully, an individual must be able to perform each essential duty satisfactorily. The requirements listed below are representative of the knowledge, skill, and/or ability required. Reasonable accommodations may be made to enable individuals with disabilities to perform the essential job functions.

Education: High School diploma or G.E.D. 30 hours of college credit hours in a related field is preferred.

Experience: Previous related academic, work, volunteer, or coaching experience is highly preferred. Experience working with individuals with special needs is recommended.

CERTIFICATIONS, LICENSES, REGISTRATIONS: First Aid/CPR

PHYSICAL DEMANDS: The physical demands described here are representative of those that must be met by an employee to successfully perform the essential functions of this job. Reasonable accommodations may be made to enable individuals with disabilities to perform the essential job functions.

While performing the duties of this job the employee is required to frequently walk, bend, stoop, stand, and sit. The employee is occasionally required to lift, carry, push, and pull up to twenty-five pounds, and to lift a child with assistance up to 100 pounds. They will also be required to occasionally run, kneel, twist, and squat.

WORK ENVIRONMENT: The work environment characteristics described here are representative of those an employee encounters while performing the essential functions of this job. Reasonable accommodations may be made to enable individuals with disabilities to perform the essential functions.

The work environment will vary depending on the program the Inclusion Aide is assigned to. Work may be outside in hot, warm, and cool weather; in village owned facilities, or other indoor or outdoor facilities. The work environment may be hectic, busy and noisy depending on the program.

Nothing in this job description restricts management's right to assign or reassign duties and responsibilities to this job at any time.

Official copies maintained in Human Resources. Printed copies may be dated.

Village of Orland Park

Position Description

POSITION TITLE: Program Assistant – Special Recreation (part-time)
DEPARTMENT: Recreation and Parks
CATEGORY: Paraprofessional
REPORTS TO: Special Recreation Program Supervisor
FLSA STATUS: Non-Exempt
PREPARED BY: Kathleen Hellwig, Recreation Program Supervisor,
Angela Arrigo, HR Generalist
PREPARED DATE: February 2015



-

POSITION SUMMARY:

The Program Assistant is responsible for providing general assistance for Special Olympics, Special Recreation large scale events, fundraisers, overnight programs, and general special recreation programs.

ESSENTIAL DUTIES AND RESPONSIBILITIES:

1. Regular and consistent attendance is required for this position.
2. Assist Special Recreation Specialist in oversight of Special Olympic tournaments and teams including transportation planning needs, scheduling, facilities, and staffing coordination.
3. Will coordinate the Special Olympic scheduling events with Special Recreation Specialist to ensure scheduling objectives are met for the Special Olympics programming.
4. This position will order, maintain, and inventory Special Olympic uniforms and equipment throughout the year.
5. Provide support scheduling and planning for other large scale special recreation events and fundraisers. Provide coverage at alternate sites for programs and events with lead staff.
6. Actively lead specified general programs (week day and evenings), one day trips (3 to 4 a season), and Special Recreation planned events (4 to 5 a year). Attend and coordinate 3 to 4 overnight trips a year.
7. Respond to emergent transportation issues in absence of Special Recreation Coordinator or Specialist.
8. In absence of Special Recreation Coordinator, will be responsible for:
 - a. Staffing ratio's
 - b. Staffing assignments/substitutions
 - c. Attendance for both staff/ participants
 - d. Regularly and consistently interact with parents to answer questions and provide information
 - e. Assisting in organizing pick up's/ drop offs/ destination directions
 - f. Coordinating training needs and assignments
 - g. Ensure safety of all program participants and inclusion participates
9. Complete all necessary documentation for the assigned projects. Documentation may include but is not limited to; Special Olympic score sheets, ratings etc.; department forms incident/accident report forms, support notes etc.
10. Purchase required program supplies for Special Recreation Division programming and events.
11. Ensure compliance to budget for all expenditures. Prepare all necessary purchase requisitions and credit card requests for supplies, work orders, etc. needed for programs and special events.
12. Assist with all cash handling procedures for annual fundraisers.
13. Must be able to drive special recreation non-CDL vehicles.
14. Other duties as assigned.

SUPERVISION RECEIVED: General supervision received from the Special Recreation Program Supervisor. The Program Assistant reports directly to the Special Recreation Program Specialist and Coordinator. The Special Recreation

Nothing in this job description restricts management's right to assign or reassign duties and responsibilities to this job at any time.

Official copies maintained in Human Resources. Printed copies may be dated.

Program Specialist and Coordinator report directly to the Special Recreation Program Supervisor.

MANAGERIAL/SUPERVISORY RESPONSIBILITIES: None

POSITION REQUIREMENTS:

To perform this job successfully, an individual must be able to perform each essential duty satisfactorily. The requirements listed below are representative of the knowledge, skill, and/or ability required.

Education: High School Diploma required an associate's or bachelor's degree in the recreation or therapeutic recreation fields is preferred.

Experience: A minimum of two years working in a recreation, therapeutic, or related field is preferred. Prior experience with ADLs is preferred. Experience/training in implementing behavior management techniques and having knowledge of cognitive and developmental impairments is highly recommended.

Must have excellent communication and organizational skills. Must be proficient with Microsoft Office.

CERTIFICATIONS, LICENSES, REGISTRATIONS: First Aid/CPR. Maintain valid driver's license. Must obtain and maintain medical certification to drive village vehicles upon hire.

PHYSICAL DEMANDS:

The physical demands described here are representative of those that must be met by an employee to successfully perform the essential functions of this job. Reasonable accommodations may be made to enable individuals with disabilities to perform the essential job functions.

While performing the duties of this job the employee will be required to frequently walk and sit, occasionally bend, stoop, crawl, kneel, twist, and squat. They will occasionally be required to lift and carry twenty-five pounds or more and to lift a child with assistance up to 100 pounds. This position will be required to serve as a back-up van driver when needed, and must be able to drive required vehicles.

WORK ENVIRONMENT:

The work environment characteristics described here are representative of those an employee encounters while performing the essential functions of this job.

The work environment will vary depending on the program the Program Assistant is assigned to. Work will be in an office environment. In addition, work may be outside in hot, warm, and cool weather; in village owned facilities, or other indoor or outdoor facilities. The work environment may be hectic, busy, and noisy depending on the program.

Village of Orland Park

Position Description

POSITION TITLE: Recreation II/ Bus Driver (part-time)
DEPARTMENT: Recreation and Parks
CATEGORY: Paraprofessional
REPORTS TO: Special Recreation Supervisor
FLSA STATUS: Non-exempt
PREPARED BY: Kathleen Hellwig
PREPARED DATE: November 2014



POSITION SUMMARY:

This position is responsible for providing an optimal experience in recreation working with individuals with special needs. Recreation Instructor II/ Bus Drivers will work with children, young adults, older adults with special needs enrolled in Special Recreation Programs. These programs are designed to provide vocational, leisure and social activities to our participants. Programming includes Special Olympic Sports, Special Events, General Programming, Overnight trips, and Inclusion. In addition, this position is responsible for transporting participants to and from program locations while driving a vehicle that requires a class B or C Commercial Driver's License with a passenger endorsement.

ESSENTIAL DUTIES AND RESPONSIBILITIES:

1. Will supervise, coach and assist participants enrolled in special recreation programs.
2. Provide assistance tailored to the individual needs of participants throughout the program to ensure a successful program experience.
3. Provide redirection techniques and behavior management skills when need to ensure the participants safety and well-being. Responsible for implementing parallel, inclusive or adaptive activities to promote optimal experience for participants with special needs.
4. Provides vocational, leisure, and social activities for participants registered in Recreation Programming.
5. Complete all necessary documentation in the event that there is an incident/emergency involving a participant and/or vehicle.
6. Responsible for safely transporting program participants as part of a program route. Responsible for picking up and dropping off participants from their current residence to Orland Park or other program facilities for sporting/special events/ general programming.
7. Responsible for safely transporting program participants from a designated Village facility to and from special events.
8. Responsible for safely transporting program participants within the Chicagoland area as well as neighboring states for overnight/special events.

SUPERVISION RECEIVED: General supervision received from the Special Recreation Program Supervisor. The Recreation Instructor II/Bus Driver reports directly to the Special Recreation Program Specialist and Coordinator. The Special Recreation Program Specialist and Coordinator report directly to the Special Recreation Program Supervisor.

MANAGERIAL/SUPERVISORY RESPONSIBILITIES: None

POSITION REQUIREMENTS: To perform this job successfully, an individual must be able to perform each essential duty satisfactorily. The requirements listed below are representative of the knowledge, skill, and/or ability required. Reasonable accommodations may be made to enable individuals with disabilities to perform the essential job functions.

Education: High School diploma or G.E.D. 30 hours of college credit in a related field is preferred.

Nothing in this job description restricts management's right to assign or reassign duties and responsibilities to this job at any time.

Official copies maintained in Human Resources. Printed copies may be dated.

Experience: Previous related academic, work, volunteer, or coaching experience is required. Experience working with individuals with special needs is also required. Experience/training in implementing behavior management techniques and having knowledge of cognitive and developmental impairments is highly recommended.

Must be 21 years of age, with a clean driving record for at least the past 1 year, Class B or C CDL license with a P Passenger endorsement to drive our 21 passenger vehicles and, must pass background check, US DOT physical examination and alcohol and drug testing.

CERTIFICATIONS, LICENSES, REGISTRATIONS: First Aid/CPR certified, class B or C CDL license with a P Passenger endorsement and a Department of Transportation (DOT) medical certification.

PHYSICAL DEMANDS: The physical demands described here are representative of those that must be met by an employee to successfully perform the essential functions of this job. Reasonable accommodations may be made to enable individuals with disabilities to perform the essential job functions.

While performing the duties of this job the employee will continuously drive and operate the accessibility equipment on the vehicle. The employee is required to frequently walk, bend, stoop, stand, and sit. The employee is occasionally required to lift, carry, push, and pull up to twenty-five pounds, and to lift a child with assistance up to 100 pounds. They will also be required to occasionally run, kneel, twist, and squat.

WORK ENVIRONMENT: The work environment characteristics described here are representative of those an employee encounters while performing the essential functions of this job. Reasonable accommodations may be made to enable individuals with disabilities to perform the essential functions.

The work environment will vary depending on the program the Recreation Instructor II/Bus Driver is assigned to. Work may be outside in hot, warm, and cool weather; in village owned vehicles, or facilities, or other indoor or outdoor facilities. The work environment may be hectic, busy, and noisy depending on the program. Constant driving to and from programs with or without participants is required.

DRAFT

Village of Orland Park

Position Description



POSITION TITLE: Recreation Program Supervisor I
DEPARTMENT: Recreation and Parks
CATEGORY: General Managerial
REPORTS TO: Recreation Operations Manager
FLSA STATUS: Exempt
PREPARED BY: Irene Buikema, Recreation Operations Manager
PREPARED DATE: April 21, 2015

POSITION SUMMARY: Under general direction, this position is responsible for the planning, coordination and review of leisure services and programs for individuals with special needs.

Developing, budgeting, implementing, and supervising recreational opportunities for special recreation are key responsibilities of this role. This position is also responsible for building and furthering current partnerships within the local community and with supporting agencies. In addition, this position will oversee and/or assist with various special events. This position will require occasional evening or weekend hours depending on events and programming.

This position will manage the day-to-day operations with a highly qualified staff of one full-time recreation specialist and two part-time program coordinators and collaborate with staff to hire, train, and supervise approximately 40 part-time recreation instructors and 20 seasonal employees.

Programming includes the largest Special Olympics program in the local area along with a variety of regular programming ranging from athletics & fitness, cultural, artistic, social, job training, inclusion, and trips.

ESSENTIAL DUTIES AND RESPONSIBILITIES:

1. Regular and consistent attendance is required for this position.
2. Supervises (hires, trains, evaluates) staff and service vendors/contractors; sets performance standards and prioritizes work; approves time sheets, volunteer credit and personnel action forms and ensures their accuracy; participates in the selection, evaluation, motivation and discipline of staff; receives and investigates accidents and complaints relative to programs, contractors and staff; reports findings and recommends appropriate corrective action; conducts employee and volunteer training and program meetings.
3. Develops marketing and promotional materials for programs, this includes but is not limited to assisting with brochure preparation, writing program descriptions, proofing text and lay outs, developing flyers, posters, etc.
4. Participates in coordination of activities related to the development of programs in areas of responsibility including, but not limited to: preparation of forms, program brochure, and reports, cost analyses, program curriculums and lesson plans (if applicable), parent communication, budgets, recaps, purchase orders, program purchases, assist with requests for proposals, program evaluations and documentation, serves a substitute instructor, as needed; assists instructor in emergency situations.
5. Manages the Recreation department transportation needs. Schedules and coordinates the fleet of Recreation vehicles, specifically busses used for special recreation programming. Schedules staff and ensures staff has appropriate training, certifications, and licensure. Coordinates with other Recreation Program supervisors to ensure availability of vehicles and drivers as needed. Works with the Vehicle and Equipment division for vehicle maintenance.
6. Performs other duties as required, including assisting with Recreation department special events as assigned.

SUPERVISION RECEIVED: General direction received from the Recreation Operations Manager

MANAGERIAL/SUPERVISORY RESPONSIBILITIES: 1 Special Recreation Specialist, 2 Special Recreation Program Coordinators, 1 Program Assistant, 40 year round staff and approximately 20 seasonal staff.

POSITION REQUIREMENTS: To perform this job successfully, an individual must be able to perform each essential duty satisfactorily. The requirements listed below are representative of the knowledge, skill, and/or ability required. Reasonable accommodations may be made to enable individuals with disabilities to perform the essential job functions.

Education: Bachelor's degree in Therapeutic Recreation or closely related field. Master's Degree is preferred. Must have an in depth knowledge of ADA standards and inclusion best practices. CTRS certification is required. CPRP certification is preferred.

Experience: Must have at least 5 years direct experience creating and directing therapeutic and recreational

programs, including inclusion, special recreation camps and trips. 3 – 5 years supervisory experience is required.

A confident, proactive and collaborative leadership style, along with strong interpersonal, oral and written communication, and organizational skills are needed. Skill in intergovernmental communications, building sound relationships and fostering new partnerships is needed. A positive team oriented attitude is required.

Strong analytical, budgeting, fiscal management, solid judgment, supportive and motivating leadership style and partnership oriented attitude are needed.

Solid computer skills including knowledge and experience with Microsoft Excel, Word, and Power Point, is needed. The ability to create press ready documents, high level reports, and other documents is necessary. In addition, strong detail orientation and the ability to set and meet deadlines are needed.

CERTIFICATIONS, LICENSES, REGISTRATIONS: First Aid/CPR, State of Illinois Driver's License (CDL Driver's License is preferred), CTRS required, CPRP recommended

PHYSICAL DEMANDS: The physical demands described here are representative of those that must be met by an employee to successfully perform the essential functions of this job. Reasonable accommodations may be made to enable individuals with disabilities to perform the essential job functions.

While performing the duties of this job the employee will continuously sit and work at a computer and communicate with others via phone and in person. This position will occasionally drive and frequently walk, bend, stoop, and stand. The employee may be occasionally required to lift, carry, push, and pull up to twenty-five pounds, and to lift a child with assistance up to 100 pounds. They will also be required to occasionally run, kneel, twist, and squat.

WORK ENVIRONMENT: The work environment characteristics described here are representative of those an employee encounters while performing the essential functions of this job. Reasonable accommodations may be made to enable individuals with disabilities to perform the essential functions.

Work will primarily be in an office environment. In addition, work may be outside in hot, warm, and cool weather; in village owned vehicles or facilities, or other indoor or outdoor facilities. The work environment may be hectic, busy, and noisy depending on the program.

Village of Orland Park

Position Description

POSITION TITLE: Special Recreation Instructor I & II
DEPARTMENT: Recreation and Parks
CATEGORY: Paraprofessional
REPORTS TO: Recreation Program Supervisor
FLSA STATUS: Non-Exempt
PREPARED BY: Kathleen Hellwig
PREPARED DATE: November 2014



POSITION SUMMARY: This position is responsible for providing an optimal experience in recreation for individuals with disabilities. Recreation Instructors will work with children, young adults, and older adults with special needs enrolled in Special Recreation programs designed to provide vocational, leisure, and social activities to participants. Programming includes but is not limited to Special Olympic sports, special events, general programming, overnight trips, and inclusion.

ESSENTIAL DUTIES AND RESPONSIBILITIES:

1. Regular and consistent attendance is required for this position.
2. Will supervise, coach and assist participants enrolled in special recreation programs.
3. Provide assistance tailored to the individual needs of participants, throughout the program to ensure a successful program experience.
 - a. Provide redirection techniques and behavior management skills when needed to ensure the participants safety and well-being.
 - b. Responsible for implementing parallel, inclusive or adaptive activities to promote optimal experience for participants with special needs.
4. Provide vocational, leisure, and social activities for participants registered in Recreation Programming.
5. Complete the all necessary documentation for the assigned program. Documentation may include but is not limited to; Special Olympic score sheets, ratings etc.; department forms incident/accident report forms, support notes etc.
6. Contact participant's parent or guardian as needed regarding program updates, changes, transportation, weather conditions or other pertinent information.
7. Keep department management aware of issues or problems that arise during a program.

SUPERVISION RECEIVED: General supervision received from the Special Recreation Program Supervisor. Recreation Instructors report directly to a Special Recreation Program Specialist or Coordinator. The Special Recreation Program Specialist or Coordinator reports directly to the Special Recreation Program Supervisor.

MANAGERIAL/SUPERVISORY RESPONSIBILITIES: None

POSITION REQUIREMENTS: To perform this job successfully, an individual must be able to perform each essential duty satisfactorily. The requirements listed below are representative of the knowledge, skill, and/or ability required. Reasonable accommodations may be made to enable individuals with disabilities to perform the essential job functions.

Education: High School diploma or G.E.D. 30 hours of college credit in a related field is preferred.

Experience: Previous related academic, work, volunteer, or coaching experience is required. Experience working with individuals with special needs is also required. Experience/training in implementing behavior management techniques and having knowledge of cognitive and developmental impairments is highly recommended.

CERTIFICATIONS, LICENSES, REGISTRATIONS: CPR/First Aid, State of Illinois Driver's License (CDL Driver's License is preferred)

PHYSICAL DEMANDS: The physical demands described here are representative of those that must be met by an employee to successfully perform the essential functions of this job. Reasonable accommodations may be made to

Nothing in this job description restricts management's right to assign or reassign duties and responsibilities to this job at any time.

Official copies maintained in Human Resources. Printed copies may be dated.

enable individuals with disabilities to perform the essential job functions.

While performing the duties of this job the employee is required to frequently walk, bend, stoop, stand, and sit. The employee is occasionally required to lift, carry, push, and pull up to twenty-five pounds, and to lift a child with assistance up to 100 pounds. They will also be required to occasionally drive, run, kneel, twist, and squat.

WORK ENVIRONMENT: The work environment characteristics described here are representative of those an employee encounters while performing the essential functions of this job. Reasonable accommodations may be made to enable individuals with disabilities to perform the essential functions.

The work environment will vary depending on the program the Recreation Instructor is assigned to. Work may be outside in hot, warm, and cool weather; in village owned facilities, or other indoor or outdoor facilities. The work environment may be hectic, busy, and noisy depending on the program. Some driving to and from programs with or without participants may be required.

Village of Orland Park

Position Description

POSITION TITLE: Recreation Instructor II/ Specialist (Part-Time)
DEPARTMENT: Recreation and Parks
CATEGORY: Paraprofessional
REPORTS TO: Special Recreation Program Supervisor
FLSA STATUS: Non-Exempt
PREPARED BY: Kathleen Hellwig
PREPARED DATE: December 2014



POSITION SUMMARY: The Recreation Instructor II Specialist is responsible for providing general oversight for general programs/ special events/ Special Olympics/ overnight programs

ESSENTIAL DUTIES AND RESPONSIBILITIES:

1. Regular and consistent attendance is required for this position.
2. Attend scheduled weekly Special Recreation Programs and Special Events.
3. Providing oversight to the following areas of the special recreation division: general programs, special events, Special Olympics, and overnight programs.
4. Implement program lesson plans provided by the Special Recreation Program Coordinator.
5. Act as a lead staff, which includes parent conversations, emergent transportation issues, sudden illness, staff/ participant ratios.
6. Actively lead the following programs: general programs (week day and evenings), one day trips (3 to 4 a season), and special events (4-5 a year).
7. Attend/ co- lead 3-4 overnight trips a year.

SUPERVISION RECEIVED: General supervision received from the Special Recreation Program Supervisor. The Program Assistant reports directly to the Special Recreation Program Specialist and Coordinator. The Special Recreation Program Specialist and Coordinator report directly to the Special Recreation Program Supervisor.

MANAGERIAL/SUPERVISORY RESPONSIBILITIES: Will serve as a lead at various programs

POSITION REQUIREMENTS: To perform this job successfully, an individual must be able to perform each essential duty satisfactorily. The requirements listed below are representative of the knowledge, skill, and/or ability required.

Education: High School Diploma required an associate's or bachelor's degree in the recreation or therapeutic recreation fields is preferred.

Experience: A minimum of two years working in a recreation, therapeutic, or related field is preferred. Prior experience with ADLs is preferred. Experience/training in implementing behavior management techniques and having knowledge of cognitive and developmental impairments is highly recommended.

CERTIFICATIONS, LICENSES, REGISTRATIONS: First Aid/CPR. Maintain valid driver's license. Must maintain medical certification for driving village vehicles.

PHYSICAL DEMANDS: The physical demands described here are representative of those that must be met by an employee to successfully perform the essential functions of this job. Reasonable accommodations may be made to enable individuals with disabilities to perform the essential job

Nothing in this job description restricts management's right to assign or reassign duties and responsibilities to this job at any time.

Official copies maintained in Human Resources. Printed copies may be dated.

functions.

While performing the duties of this job the employee will be required to frequently walk and sit, occasionally bend, stoop, crawl, kneel, twist, and squat. They will occasionally be required to lift and carry twenty-five pounds or more and to lift a child with assistance up to 100 pounds. This position will be required to serve as a back-up van driver when needed, and must be able to drive required vehicles.

WORK ENVIRONMENT: The work environment characteristics described here are representative of those an employee encounters while performing the essential functions of this job.

The work environment will vary depending on the program the Recreation Instructor II/Specialist is assigned to. Work may be outside in hot, warm, and cool weather; in village owned facilities, or other indoor or outdoor facilities. The work environment may be hectic, busy, and noisy depending on the program.

Village of Orland Park

Position Description

POSITION TITLE: Special Recreation Program Coordinator (Part-Time)
DEPARTMENT: Recreation and Parks
CATEGORY: Paraprofessional
REPORTS TO: Special Recreation Supervisor
FLSA STATUS: Non-Exempt
PREPARED BY: Kathleen Hellwig
PREPARED DATE: November 2014



POSITION SUMMARY: This position will oversee the coordination of weekly programs, staff supervision, inclusion assignments, special event planning and summer camp support

ESSENTIAL DUTIES AND RESPONSIBILITIES:

1. Regular and consistent attendance is required for this position.
2. Develop, plan, implement, and evaluate programming for the Special Recreation Division.
3. Plan special events to meet programming needs (i.e. transportation, registration, location, staffing, food and beverage purchase, entertainment).
4. Coordinates staffing needs for programming including direct supervision of program instructors and inclusion aides.
5. Motivates staff to ensure successful program and encourage creative ideas to be shared with focus on continual improvement of programming.
6. Assists the Special Recreation Program Supervisor with selection of qualified applicants for staffing needs.
7. Responsible for all transportation needs for the program including scheduling routes/drivers/participants changes.
8. Coordinates availability of fleet vehicles to meet program needs.
9. Participates in scheduled programming to ensure program objectives are being met.
10. Regularly communicates with parents and program participants as needed to answer questions, provide information and address issues.
11. Oversees administrative function of programming including accident reports, timesheets, registration forms, schedules for general programming, overnight forms.
12. Oversees the related expenditures including maintaining and ordering supplies/equipment/inventory to meet program needs, shopping for programming supplies, etc.
13. Ensures compliance to budget for all expenditures. Prepares all necessary purchase requisitions and credit card requests for supplies, work orders needed for programs and special events.
14. Ensures safety of all program participants in all scheduled events.
15. Coordinates community service volunteers.
16. Completes other duties and responsibilities as assigned.
17. Coordinates details for all fundraising events (i.e. staffing needs, volunteer assignments, park maintenance orders, cash handling).

SUPERVISION RECEIVED: Direct supervision received from the Special Recreation Division Supervisor.

MANAGERIAL/SUPERVISORY RESPONSIBILITIES: This position is responsible for the oversight of part-time employees.

POSITION REQUIREMENTS: To perform this job successfully, an individual must be able to perform each essential duty

satisfactorily. The requirements listed below are representative of the knowledge, skill, and/or ability required. Reasonable accommodations may be made to enable individuals with disabilities to perform the essential job functions.

Education: High School Degree. Associate or Bachelor's degree in related field is preferred.

Experience: Minimum of 2-5 years of related experience in the recreation/education field and with two years of related administrative experience. Experience, knowledge and the ability to plan, supervise, and evaluate recreation programs is required.

Strong oral and written communication skills, organizational skills, enthusiasm to work with individuals with special needs are required. Proficiency in MS Office is also required.

Experience/training in implementing behavior management techniques and having knowledge of cognitive and developmental impairments is highly recommended.

CERTIFICATIONS, LICENSES, REGISTRATIONS: First Aid/CPR, State of Illinois Driver's License (CDL Driver's License is preferred)

PHYSICAL DEMANDS:

The physical demands described here are representative of those that must be met by an employee to successfully perform the essential functions of this job. Reasonable accommodations may be made to enable individuals with disabilities to perform the essential job functions.

While performing the duties of this job the employee will continuously sit and work at a computer and communicate with others via phone and in person. This position will occasionally drive and frequently walk, bend, stoop, and stand. The employee is occasionally required to lift, carry, push, and pull up to twenty-five pounds, and to lift a child with assistance up to 100 pounds. They will also be required to occasionally run, kneel, twist, and squat.

WORK ENVIRONMENT: The work environment characteristics described here are representative of those an employee encounters while performing the essential functions of this job. Reasonable accommodations may be made to enable individuals with disabilities to perform the essential functions.

The work environment will vary depending on the program the Special Recreation Coordinator is assigned to. Work will primarily be in an office environment. In addition, work may be outside in hot, warm, and cool weather; in village owned vehicles or facilities, or other indoor or outdoor facilities. The work environment may be hectic, busy, and noisy depending on the program.

Village of Orland Park

Position Description

POSITION TITLE: Special Recreation Specialist
DEPARTMENT: Recreation and Parks
CATEGORY: Professional/Technical
REPORTS TO: Special Recreation Program Supervisor
FLSA STATUS: Exempt
PREPARED BY: Kathleen Hellwig/Irene Buikema/Stephana Przybylski
PREPARED DATE: July 11, 2012



POSITION SUMMARY:

Under direct supervision, this position will oversee the Special Olympics program; plan, implement, and evaluate special recreation programs and specific special events.

ESSENTIAL DUTIES AND RESPONSIBILITIES:

1. Regular and consistent attendance is required for this position.
2. Oversees the entire administrative function of the Special Olympic Program. Specifically responsible for establishing rosters for specific teams, schedule all team practices/games, facility management for SO programs, attend SO ITRS/district meetings, oversee/train SO coaches, assign coaches/drivers, create/distribute transportation routes, documenting all SO tournaments/ITRS Tournaments/State Tournaments, communicate with all other participating agencies/schools, document all coaches paperwork, host various ITRS Tournaments, attend SO/ITRS meetings, attend various state tournaments, among other duties.
3. Works in conjunction with direct supervisor with supervision of all part-time recreation instructors.
4. Works in conjunction with direct supervisor regarding all transportation needs for fleet of vehicles for Recreation Department. Maintain required driver's license/medical requirements and transport participants as needed.
5. Plans, implements and evaluates special recreation programs and specific special events.
6. Prepares all necessary purchase requisitions and credit card requests for supplies, work orders needed for programs and special events.
7. Orders and maintains all sports uniforms, supplies, equipment, and inventory as they apply to the programs.
8. Provides program recaps for all Special Olympic programs.
9. Prepares appropriate sections of the quarterly recreation brochure.
10. Attends weekend and overnight programs when assigned.
11. Assists with all Special Recreation fundraisers.
12. Completes other duties and responsibilities as assigned.

SUPERVISION RECEIVED: Direct supervision received from the Special Recreation Program Supervisor.

MANAGERIAL/SUPERVISORY RESPONSIBILITIES: This position is responsible for the oversight of part-time employees in conjunction with the Special Recreation Program Supervisor.

POSITION REQUIREMENTS: To perform this job successfully, an individual must be able to perform each essential duty satisfactorily. The requirements listed below are representative of the knowledge, skill, and/or ability required. Reasonable accommodations may be made to enable individuals with disabilities to perform the essential job functions.

Education: Bachelor's Degree in Therapeutic Recreation or related field

Experience: Minimum of 2-5 years of related experience in the Special Recreation field and with two years of Special Olympic administrative experience is required. Experience/training in implementing behavior management techniques and having knowledge of cognitive and developmental impairments is highly recommended.

Experience, knowledge and the ability to plan, supervise, and evaluate recreation programs, Special

Olympics, and special events for persons with special needs is required.

Strong oral and written communication skills, organizational skills, enthusiasm to work with special populations are required. Proficiency in MS Office is also required.

Must be 21 years of age, with a clean driving record for at least the past 1 year, Class B or C CDL license with a P Passenger endorsement to drive our 21 passenger vehicles and, must pass background check, US DOT physical examination and alcohol and drug testing.

CERTIFICATIONS, LICENSES, REGISTRATIONS: First Aid/CPR certified, class B or C CDL license with a P Passenger endorsement (within 6 months of employment) and a Department of Transportation (DOT) medical certification.

PHYSICAL DEMANDS: The physical demands described here are representative of those that must be met by an employee to successfully perform the essential functions of this job. Reasonable accommodations may be made to enable individuals with disabilities to perform the essential job functions.

While performing the duties of this job the employee will continuously sit and work at a computer and communicate with others via phone and in person. This position will occasionally drive and frequently walk, bend, stoop, and stand. The employee is occasionally required to lift, carry, push, and pull up to twenty-five pounds, and to lift a child with assistance up to 100 pounds. They will also be required to occasionally run, kneel, twist, and squat.

WORK ENVIRONMENT: The work environment characteristics described here are representative of those an employee encounters while performing the essential functions of this job. Reasonable accommodations may be made to enable individuals with disabilities to perform the essential functions.

The work environment will vary depending on the program the Special Recreation Specialist is assigned to. Work will primarily be in an office environment. In addition, work may be outside in hot, warm, and cool weather; in village owned vehicles or facilities, or other indoor or outdoor facilities. The work environment may be hectic, busy, and noisy depending on the program.

Nothing in this job description restricts management's right to assign or reassign duties and responsibilities to this job at any time.

Official copies maintained in Human Resources. Printed copies may be dated.

Appendix B

Communication Initiatives to Improve Accessibility

The Village will place emphasis on the communication initiatives described below to provide more awareness to persons with disabilities. Initiatives are on-going and updated as needed.

2014

Brochure and Website

The Winter/ Spring 2014/2015 brochure and the Village website include verbiage highlighting the ADA accessibility and Inclusive Services

- General Registration
- Special Recreation Introduction Page
- Registration Form
- Special Recreation Form
- Brochure - throughout

Online Registration

Language referencing registration for inclusion services was added to the online registration page in late 2014.

Village Website - Special Recreation Division Pages

Provide detailed information regarding services provided through the Special Recreation Division.

2015

Brochure

All brochures include verbiage throughout highlighting ADA accessibility and Inclusive Services.

Village Website – Main Site

Online accessibility to the Village's ADA policy and procedures

Village Website – Online Registration

Alerts will be added to the registration process informing the participant that they must review and update their required information with the department. Forms to be updated include but may not be limited to, the participant information form, Special Olympics health form, seizure form, medication form, overnight form, etc.

Inclusion alerts

Within the brochure and website emphasis will be placed on informing and promoting the inclusion services offered through the Recreation Department.

Public Relations/Media Requests

The following areas will be enhanced to promote awareness of programming and events available to special needs participants.

- Photography in Recreation brochure
- Photography on Village website
- Photography in flyers, posters and other advertisements

2016 Goals & Objectives

Brochure

All brochures include verbiage throughout highlighting ADA accessibility and Inclusive Services

Village Website – Online Registration

Persons with disabilities seeking to register for traditional recreation programs, and who require an aide, must currently register in person. The Department will modify this system to permit online inclusive registration through Active Network anticipated 12/31/16.

Village Website – Main Site

Online accessibility to the American's with Disabilities Act

Online links to accessible services in our community

- Community partners that serve and support persons with disabilities
- Transportation partners that service and support persons with disabilities
- Adaptive services in the community

Village Website – Recreation Department Web Pages

Links provided within the Recreation Department section in the following areas to support ADA and Inclusive Services

- Special Events
- Volunteer Opportunities
- General Interest
- Aquatics
- Athletics
- Cultural Programming

2017

Village Website

Utilizing the accessible features built into the Village website, provide an environment that is more convenient and more available to everyone – including users with disabilities.

Village Website – Parks pages

Links provided within Facilities Section of the Parks Department pages to raise the awareness of the accessible facilities in the Village of Orland Park parks and facilities.

Village Brochure – Parks pages

Links provided within Parks Amenities foldout section in the Recreation brochure to raise the awareness of the accessible facilities in the Village parks and facilities.

DRAFT

LEARN TO SWIM LESSONS

LOCATION: Centennial Pool

FEE: \$55.00(R)/\$83.00(N) for 8:45 AM to 9:30 AM lessons
 \$60.00(R)/\$90.00(N) for 9:45 AM to 10:30 AM lessons
 \$65.00(R)/\$98.00(N) for 10:45 AM to 11:30 AM lessons
 and all Evening Swim Lessons

REGISTRATION DEADLINE: The Thursday before the start of each session.

Learning to swim is an *essential* life skill best achieved at an early age. Becoming a proficient swimmer is an important step to ensure your child's safety in/around water. CPAC Swim lessons have been adapted by the Learn-To-Swim staff from leading swim instruction institutions to ensure progression in your child's swim skills. **Parents with a CPAC or Red Cross Swim Card should use the last level achieved by the student as a part of the registration process. Those without a swim card, should indicate "pretest" as the child's ability status.**

Student to instructor ratio is a maximum of 4:1 for 3 & 4 year olds and 7:1 for 5-15 year olds. Consistent attendance is necessary for a child to make progress in his/her swim ability. Parents are welcome to stay pool side to observe classes throughout the swim session. **One week notice is required for refunding out of class.**

MORNING SWIM LESSONS

1ST WEEK: Monday thru Friday
2ND WEEK: Monday thru Wednesday
SESSION 1: Jun 20 to Jun 29
SESSION 2: Jul 11 to Jul 20
SESSION 3: Jul 25 to Aug 3

AGE *2 TO 4 | LIMIT: 30

SESS 1	SESS 2	SESS 3	TIME:
79825	79831	79837	8:45 AM to 9:30 AM
79826	79832	79838	9:45 AM to 10:30 AM
79827	79833	79839	10:45 AM to 11:30 AM

***2 yr. olds that have participated in Parent/Tot class**

AGE 5 TO 15 | LIMIT: 150

SESS 1	SESS 2	SESS 3	TIME:
79828	79834	79840	8:45 AM to 9:30 AM
79829	79835	79841	9:45 AM to 10:30 AM
79830	79836	79842	10:45 AM to 11:30 AM

EVENING SWIM LESSONS

DATE: Jun 13 to Jul 11 (*no class July 4*)
DAY: Monday & Wednesday
TIME: 7:15 PM to 8:00 PM
PROG#: **AGE:** **LIMIT:**
 79843 3 to 4 30
 79844 5 to 15 100

A.D.A.

The Village of Orland Park Recreation Department advocates for full participation under the Americans with Disabilities Act (ADA). A request for ADA modifications or assistance at a program is required at the time of registration. Please mark the ADA box on the registration form. We recommend at least two weeks is needed to have modifications in place. *Turn to page 07 for more information.*

RIVER WALK/LAP SWIM

The facility will be open during the hours listed for self-directed exercise. Lap lanes will be open in the zero depth pool. The lazy river will be open to walk laps against the current. This is an excellent low stress/low impact work-out. Aqua shoes are recommended. **Daily fee applies.**

DATE: Jun 6 to Aug 19
DAY: Monday thru Friday
TIME: 6:30 AM to 8:30 AM
AGE: 16 & up
LOCATION: Centennial Pool
DAILY FEE: \$3.00(R)/\$6.00(N)
Members Free



MEET THE LEARN-TO-SWIM STAFF!

A parent orientation session will be held on the second day of each learn-to-swim session at the top of the hour. Meet the staff and learn about what your child will experience during his/her swim session.

ATTACK VOLLEYBALL CLASSES

DATE: Jul 6 to Aug 10
DAY: Wednesday
LIMIT: 20
LOCATION: Sportsplex, Gym 2

YOUTH DEVELOPMENT I

The most important lessons are taught at this level. Individual skill development and correct techniques of each skill are broken down and reinforced through fun drills and competition.

PROGRAM#: 80247
TIME: 3:30 PM to 4:30 PM
GRADE: K to 4th
FEE: \$60.00(R)/\$90.00(N)

YOUTH DEVELOPMENT II

Individual and group instruction on all the basic skills of the game of volleyball, plus a more advanced approach on body movement and ball work. Preparation for competition is part of the main focus.

PROGRAM#: 80248
TIME: 4:45 PM to 6:00 PM
GRADE: 5th to 8th
FEE: \$73.00(R)/\$110.00(N)



GOLF LESSONS AT WHITE MOUNTAIN

Golf lessons will be taught by Dennis Piotrowski, PGA Golf Professional and his staff at White Mountain Golf Course. All students receive instruction within a group format including proper grip, stance, full swing, pitching, putting, rules and etiquette. A \$5.00 range ball fee will be payable to the instructor at each class. Students are to bring a 7 iron to the first lesson. NOTE: White Mountain Pro Shop will shorten old clubs and add junior grips at little cost. Call the golf shop at (708) 478-4653 at least two weeks prior to the start of class for this service.

LIMIT: 10
LOCATION: White Mountain Golf Course

MINI JUNIOR GOLF

DAY: Wednesday
TIME: 10:00 AM to 11:00 AM
AGE: 5 to 8
FEE: \$69.00(R)/\$104.00(N)
PROG#: **DATE:**
 80249 Jun 8 to Jul 6
 80250 Jul 20 to Aug 17

JUNIOR GOLF *No class July 2*

AGE: 9 to 15
FEE: \$69.00(R)/\$104.00(N)
PROG#: **DATE:** **DAY:** **TIME:**
 80251 Jun 8 to Jul 6 W 9:00 AM to 10:00 AM
 80252 Jun 11 to Jul 16 Sa 12:00 PM to 1:00 PM
 80253 Jul 20 to Aug 17 W 9:00 AM to 10:00 AM
 80254 Jul 23 to Aug 20 Sa 12:00 PM to 1:00 PM

ADULT GOLF

DAY: Wednesday
TIME: 6:00 PM to 7:00 PM
AGE: 16 & up
FEE: \$79.00(R)/\$119.00(N)
PROGRAM#: **DATE:**
 80267 Jun 8 to Jul 6
 80268 Jul 20 to Aug 17

UNDER THE AMERICANS WITH DISABILITIES ACT (ADA)

The Recreation Department welcomes participation in all programs by individuals with disabilities and special needs. The Special Recreation division provides inclusion aides to assist the participant with program activities and will make reasonable modifications for the individual. Information on how to request for ADA modification can be found on the registration information page 07.

PRESCHOOL 2016 / 2017

FRANKLIN LOEBE CENTER

Our Preschool program is designed to provide your child with the opportunity to develop skills needed for individual learning and play. The program includes academics, arts & crafts, games, holiday parties and field trips, with emphasis on motor coordination and socialization. Preschool is a continuous program beginning in September and ending in May.

A \$25 Junior/\$50 Senior non-refundable deposit, along with a credit card number, if choosing a payment plan, and a copy of your child's county birth certificate will be due when registering. **PLEASE NOTE:** *Your payment and registration will be returned without a copy of a birth certificate on file.* Children must reach the age of 3 or 4 on or before September 1, 2016, and must be potty trained. Classroom assignments will be given at the parent meeting prior to start of class.

PRESCHOOL • JUNIORS • AGE: 3 September 12—May 11

Tuesday & Thursday—2 HRS.

LIMIT: 16 per class | **FEE:** \$629.00(R)/\$786.00(N)

PROGRAM#:	TIME:
79529	8:45 AM to 10:45 AM
79527	9:15 AM to 11:15 AM
79530	11:45 AM to 1:45 PM
79531	12:15 PM to 2:15 PM

Monday & Wednesday—2.5 HRS.

LIMIT: 16 per class | **FEE:** 678.00(R)/\$848.00(N)

PROGRAM#:	TIME:
79528	12:00 PM to 2:30 PM

PRESCHOOL • SENIORS • AGE: 4-5 September 12—May 17

Monday, Wednesday & Friday—2.5 HRS.

LIMIT: 20 per class | **FEE:** \$1016.00(R)/\$1270.00(N)

PROGRAM#:	TIME:
79547	8:30 AM to 11:00 AM*
79545	9:00 AM to 11:30 AM*
79548	12:00 PM to 2:30 PM
79546	12:30 PM to 3:00 PM

*Young Achievers is only available for the noted classes above.

PRESCHOOL PAYMENT SCHEDULE

Registration deposit: \$25 Juniors/\$50 Seniors
(non-refundable)

1st payment Aug 5* 1/3 of balance after deposit

2nd payment, Oct 5* 1/3 of balance

3rd payment, Dec 5* Remainder of balance

*if prior payment has not been made

DISCOUNTS

• 2nd child \$50 off • 3rd child \$25 off.

No refunds will be given after Dec. 5.

YOUNG ACHIEVERS

This enrichment program is designed as a continuation of time directly before or after the senior preschool class. This is for the child that is both academically and socially ready for kindergarten, but not old enough. **New this year - Young Achievers will be a continuous program beginning in September and ending in May.**

Each child is required to bring a brown bag lunch—lunch will not be provided. Activities will include: nature, science, arts & crafts, math and games. Your child will be walked from classroom to classroom. Your child must be enrolled in a senior preschool program in order to register for this class. Prerequisite: child should be able to print name and use scissors correctly. **A \$25 non-refundable deposit is included in the initial payment due at time of registration, along with a credit card number if choosing the payment plan.** (Please consult Preschool and District 135 calendars for no class dates.)

DATE:	September 14 to May 17	
DAY:	Monday, Wednesday & Friday	
AGE:	4 to 5	
LIMIT:	20	
LOCATION:	Franklin Loebe Center	
FEE:	\$445.00(R)/\$668.00(N)	
PROGRAM#:	COURSE:	TIME:
80198	AM Pre. #79747	11:00 AM to 12:30 PM
80197	PM Pre. #79545	11:30 AM to 1:00 PM

YOUNG ACHIEVERS PAYMENT SCHEDULE

DUE DATE: **PAYMENT DUE:**
1/3 due at time of registration

Sept 5* 1/3 of balance

Nov 5* Remainder of balance

*If prior payment has not been made. No refunds after Dec. 20.

UNDER THE AMERICANS WITH DISABILITIES ACT (ADA)

The Recreation Department welcomes participation in all programs by individuals with disabilities and special needs. The Special Recreation division provides inclusion aides to assist the participant with program activities and will make reasonable modifications for the individual. Information on how to request for ADA modification can be found on the registration information page 86.

PROCEDURE FOR ALL PAYMENT PLANS

We require a credit card number for all payment schedules. Payments can be taken prior to the scheduled due date by cash or check or credit card. All payments will be charged to your credit card on the due date if not paid in advance. A \$25 service charge will be assessed for all rejected credit card payments.

RANDOM RESIDENT REGISTRATION

Registration for Village of Orland Park residents only will be accepted upon receipt of the brochure. These registrations will be held until **Thursday, April 21**, and will then be entered on a random basis along with any forms received on this day. After this date, all subsequent resident registrations will be entered on a first come, first served basis. See the Information page for proof of residency requirements.

- Review the brochure and choose your programs.
- Complete the registration form—Incomplete registration forms will not be processed.
- One family may register on each form. (immediate family members only)
- Be sure to sign the registration form.
- Mail-in, drop-off, email, or fax completed registration forms to either administrative office.

NON-RESIDENT REGISTRATION

Non-resident registration begins **Wednesday, May 4 at 8:30 AM**. Registrations are accepted at the administration offices. Times and locations are listed on the inside front cover. Non-residents may follow the online, mail-in, drop-off, email, fax, or walk-in procedures listed on the next page beginning May 14.

REFUND POLICY

1. All withdrawal requests must be made before the start of the second class and cannot be done online.
2. No refund will be granted after the second meeting of the program or without written medical excuse prior to completion of the program.
3. All refunds, including online registration, must be made in person at either administration office.
4. Effective April 4, 2016, a \$5.00 administrative charge will be assessed per program for all refunds over \$5.00 including refunds for medical reasons.
5. Refunds will not be issued if the refund amount is \$5.00 or less.
6. Refunds will not be given on special events, workshops or certain trips less than seven days prior to the date of the program.
7. No refunds will be given for adult sports leagues.
8. The online \$2.50 convenience fee is non-refundable.
9. When any program is cancelled or changed by the Recreation Department, a full refund will be given on the program. Please note: the \$2.50 online convenience fee is non-refundable.
10. Medical excuses will result in a prorated refund based upon the number of classes held prior to the date listed on the physician's excuse.
11. Please allow four to six weeks for the refund check to arrive. These may not be cashed at Village Hall.

REGISTRATION POLICIES

1. Fees for late registrations will not be prorated.
2. A certified county birth certificate is required to be on file for all participants 5 years and younger before registration will be accepted.
3. The Recreation and Parks Department reserves the right to cancel or postpone programs due to an insufficient number of participants.
4. **Parents/guardians may register for immediate family members only. Each adult must sign form.**
5. Please write down the date, time and location of your program. Registration is not complete until a confirmation e-mail receipt has been issued.
6. If there is a problem with your registration, we will try to contact you by phone or email. If we cannot reach you, the registration form will be returned by mail and your place in the program cannot be saved. Be sure to include a valid daytime phone number on all registration forms.
7. The Recreation and Parks Department is not responsible for lost or late mail or faxes.
8. The program number for each offering is listed with the description. This program number is essential for processing registration.
9. Participants or their parents (if participant is a minor) permit the taking of photos, audio and video tapes during the Recreation and Parks Department activities for publication and use as the department deems necessary.
10. Participants registering for strenuous activities are encouraged to seek a physician's approval.
11. **All registration forms must be signed. Those without signatures will be returned to the sender, thereby jeopardizing registration and program placement.**
12. **Proof of residency is required for all registrants. Falsification of residency may be grounds for non-refundable expulsion from program or membership.**
13. **Parents are welcome to attend their child's first and last class only. You will not be allowed to remain in the classroom any other days.**
14. **A \$25 service charge will be assessed on all returned checks and rejected credit card payments.**

A.D.A.

The Village of Orland Park Recreation Department advocates for full participation under the Americans with Disabilities Act (ADA). A request for ADA modifications or assistance at a program is required at the time of registration. Please mark the ADA box on the registration form. Early registration, along with a request for accommodation, is strongly suggested to assure that appropriate modifications are secured prior to the start of the program. **We recommend at least two weeks is needed to have modifications in place.** Every attempt at reasonable modifications will be made so that individuals may participate in a desired program. It may not be possible for the participant to attend the program until modifications are provided.

WELCOME TO SPECIAL RECREATION

The Village of Orland Park Recreation Department would like to welcome you to another season of programs designated for individuals with special needs. Orland Park Special Recreation provides vocational, leisure, and social activities to our participants of all ages. Please contact the following staff members if you have any questions about our specialized programming:

Kathleen Hellwig | Special Recreation Supervisor
General oversight of Special Recreation Department, 708.403.6278

Nick Harvey | Program Specialist
All Special Olympic Sports/Events, 708.403.6269

Bridget McCormick | Program Coordinator
Special Events, Trips, Friday Social & Saturday Programs 708.403.6263

Barb Rhodes | Program Coordinator
Inclusion, Volunteer Opportunities, Fundraising 708.403.6202

Justin Koebel | Program Assistant
Special Olympic/General Programming/Special Event Support 708-906-5275

ALL INFORMATION FORM (AIF)/SEIZURE FORMS:
An AIF and Seizure Form (if applicable) must be completed, signed, and received by the Recreation Department by January 2, 2016, in order to participate in the Summer Special Recreation and/or inclusion programs.

A.D.A.

The Village of Orland Park Recreation Department advocates for full participation under the Americans with Disabilities Act (ADA). A request for ADA modifications or assistance at a program is required at the time of registration. Please mark the ADA box on the registration form. Early registration, along with a request for accommodation, is strongly suggested to assure that appropriate modifications are secured prior to the start of the program. **We recommend at least two weeks is needed to have modifications in place.** Every attempt at reasonable modifications will be made so that individuals may participate in a desired program. It may not be possible for the participant to attend the program until modifications are provided.

INCLUSION

The Village of Orland Park Recreation understands that not every person with a special need or disability condition requires or desires special recreation programming. The Recreation Department welcomes participation in all programs by individuals with disabilities and special needs. The Special Recreation division provides inclusion aides to assist the participant with the program activities and will make reasonable modifications to make sure it is an optimal experience for the individual.

ATLANTO-INSTABILITY

AAI is a medical concern which requires programming precautions that may affect participation in specific programs that require extensive neck movement. If your child has Down Syndrome and you would like more information regarding Atlanto-Axial Instability, you can go to the National Down Syndrome Society (NDSS) website at www.ndss.org and click on Healthcare Associated Conditions. There you will find information on AAI.

SUMMER REGISTRATION DATES

RESIDENT REGISTRATION BEGINS April 21
NON-RESIDENT REGISTRATION BEGINS May 4
Please do not drop off non-resident registrations prior to the registration date.

REGISTER NOW—DON'T DELAY!

Program limits will be adhered to. If you wait too long, the class may be full, or cancelled due to low enrollment.

PLEASE NOTE: Participants that register for overnight trips must be completely independent with all ADL activities (feeding, grooming, toileting and dressing). Also participants must be able to share sleeping quarters with others.



SUMMER GETAWAY

And they're off... We are headed south this summer to the beautiful state of Kentucky. We will enjoy outdoor activities at Kentucky Lake, as well as a day trip to Nashville, Tennessee. Don't miss out on this amazing opportunity to explore the outdoors with your friends.

REGISTRATION DEADLINE: May 16

PROGRAM#: 79807

DATE: Jun 23 to Jun 26

DAY: Thursday, bus departs 8:00 AM
Sunday, bus returns 4:00 PM

AGE: 13 & up **LIMIT:** 12

LOCATION: Franklin Loebe Center Parking Lot

FEE: \$750.00(R)/\$1125.00(N)

PROCEDURE FOR SUMMER GETAWAY

PAYMENT PLAN 50% of deposit is due at registration, and the remaining balance will be due June 10. A credit card is required for a payment schedule. Balance due deadline must be strictly adhered to.

Appendix C

Americans with Disabilities Act (ADA) Coordinator

The Village of Orland Park's accessibility coordinator is the Assistant Village Manager. This position coordinates the efforts of the village to comply with Title II and Title III of the Americans with Disabilities Act of 1990 and revised ADA regulations implementing Title II and Title III. In addition, the accessibility coordinator administers the village's ADA grievance procedure. In the Recreation Department, the Director of Recreation and the Special Recreation Division Supervisor are the primary contacts for coordination of implementing policies and addressing grievances.

Notice Under the ADA

In accordance with the requirements of Title II and Title III of the 1990 ADA and revised regulations, the Village of Orland Park will not discriminate against qualified individuals with disabilities on the basis of disability in its services, programs, or activities.

Employment

The Village of Orland Park does not discriminate on the basis of disability in its hiring or employment practices, and complies with all regulations promulgated by the U.S. Equal Employment Opportunity Commission under Title I of the ADA.

Effective Communication

The Village of Orland Park will generally, upon request, provide appropriate aids and services leading to effective communication for qualified persons with disabilities so they can participate equally in village programs, services, and activities, including qualified sign language interpreters, documents in Braille, and other ways of making information and communications accessible to people who have speech, hearing, or vision impairments.

Modifications to Policies & Procedures

The Village of Orland Park will make all reasonable modifications to policies and programs to ensure that people with disabilities have an equal opportunity to enjoy all of its programs, services, and activities. For example, individuals with service animals are welcomed in village offices, even where pets are generally prohibited.

Anyone who requires an auxiliary aid or service for effective communication, or a modification of policies or procedures to participate in a program, service, or activity of the village, should contact the ADA Coordinator at 708-403-6155 as soon as possible, but no later than 48 hours before the scheduled event.

The ADA does not require the Village of Orland Park to take any action that would fundamentally alter the nature of its programs or services, or impose an undue financial or administrative burden.

Complaints

Complaints that a program, service, or activity of the village is not accessible to persons with disabilities should be directed to the ADA Coordinator.

Surcharges

The Village of Orland Park will not place a surcharge on a particular individual with a disability or any group of individuals with disabilities to cover the cost of providing auxiliary aids / services or reasonable modifications of policy; such as, retrieving items from locations that are open to the public but are not accessible to persons who use wheelchairs.

DRAFT

Appendix D

Training Initiatives to Improve Accessibility

The Village will place emphasis on the following training initiatives to provide more awareness to persons with disabilities. Initiatives are on-going and updated as needed.

2014

Initiated creation of ADA training manual

- Reviewed current processes, procedures, and policies

2015

Complete the ADA training manual and training program

Establish guidelines for various Recreation Department programs regarding appropriate accommodations for people with disabilities.

- Programs that have inclusive participants may require program accommodations based on the participant's specific needs. Early Childhood, Cultural, Aquatics, and Athletics will be the first to be addressed.

Training Program

Establish resources for training.

Provide training to teach Recreation Department staff to identify appropriate adaptations to equipment for people with disabilities and to identify the need for inclusion aides.

- Establish an internal inventory of supplies and equipment utilized in our programs
- Meet with department supervisors to determine what challenges instructors (both employees and contractual providers) face while serving inclusive participants.

Provide basic sign language training for Special Recreation Division staff to serve as interpreters in department programs.

Provide specialized inclusion training for Special Recreation Division staff on an ongoing basis.

- Disability Awareness/Customer Service
- Behavior Management
- Parallel Activities

2016

Training Program

Establish resources for training.

Provide customer service and disability awareness training sessions for all Village staff.

- Customer service training to include person first language and access/inclusion.
- Train all Village staff to identify barriers to accessibility at Village and Department sites and facilities and to utilize existing accessible amenities whenever possible.

Provide training to Recreation Department staff on how to include participants who use service animals at department programs.

DRAFT

Appendix E Special Recreation Division Training Manual

Items to be set in place for employment for Special Recreation

-Employee Handbook

- Training
- Expectations
- Awareness

Train special recreation staff to be able to handle personal/medical supports. The goal is that all Special Recreation staff members are equipped to manage support issues and understand the policies and procedures of the Village and Recreation Department.

PERSON FIRST LANGUAGE

“The difference between the right word and the almost right word is the difference between lightning and the lightning bug.” Mark Twain

As providers, it is our job to assure that all registrants have the opportunity to experience the same great service. However, sometimes our choice of terms or descriptors unintentionally discriminates against people with disabilities.

In reality, individuals who experience a disability or condition are considerably MORE like those without disabilities than most realize. The condition or disorder does not define the individual; it is a part of what makes them who they are. They are however, mothers, daughters, sons, fathers, soccer players, dancers, tennis players, singers, golfers, painters, swimmers, and hikers.

When making a reference to someone who *happens* to have a disability, think PERSON first, not disability first.

DO say...

...has a disability

...uses a mobility device

...has a congenital disability

...has autism

...has attention deficit hyperactivity disorder (ADHD)

...accessible entry, stall, parking

...has Down syndrome

DON'T say...

is disabled/handicapped

is wheelchair bound

birth defect

is autistic

is hyperactive

handicapped parking

retarded, mongoloid

...typically developing kids, typical kids

normal kids

...has an emotional/mental health disability

is emotionally disturbed

REMEMBER – THINK ABOUT THE *PERSON*, NOT *DISABILITY*!
Everyone is Welcome Here

Introduction of Speakers, Topic Overview, and Outcomes

I. Get Ready: Reality Check

Special recreation, access, and inclusion at the Department
Recreation as a right and a choice
Understanding diversity and how it effects inclusion
Developing a positive attitude

II. Be Willing: Quality Customer Service

A. Universal Communication

1. Analysis of your system

- Documentation to present to parents or caregivers at registration
- Pamphlets explanation special recreation programs and inclusive services
- Standard process for all full time and part time staff
- Department philosophy in inclusion
Mission and Vision Statement
- Welcome statement
- Department inclusion process
Standard process will be established and given to all Part Time and Full Time staff

2. Quick Response

- Who is called
- Communication
- Customer service
- Immediate response
- Development of steps is needed for a quick response for all inclusive participants

3. Accommodating statement

- Brochure What to do when they walk in

B. Essential eligibility

1. Class requirements of all participants

- Registration steps completed
- What to do when these are not met

2. Scenarios of possible modifications

VILLAGE OF ORLAND PARK
REASONABLE MODIFICATIONS AND POLICIES
September 3, 2015
1:00 to 4:15 p.m.

Module One: What is a Reasonable Modification?

1 pm	Introductions
105	Purpose
110	What is a Reasonable Modification?
	Mandated Supports
	Personal Supports
	Quasi-Medical or Medical Supports
145	Applying the Modifications (10 minutes each)
	Registrant with Autism
	Returning Service Member with PTSD
	Registrant using a wheelchair
	Registrant with cluster seizures
225	Conclusion

Module Two: Village of Orland Park Inclusion Policies

240	Introduction and Purpose
245	Background
255	Preparing for Supports
310	Accessibility of Sites and Facilities
325	Providing Supports
345	Limitations on Supports
55	Implementation and Improvement
405	Resources
415	Conclusion

Village of Orland Park Recreation Department



Athlete and Parent Code of Conduct

The primary purpose of this code of conduct is to ensure the safety and well-being of all athletes and coaches involved in our Special Olympics programs. All athletes and parents must abide by this code for all sports in which they are involved.

Please understand that everyone involved in our sporting events must abide by these rules. Any athlete, parent, and/or spectator not following the rules will be asked to remedy the situation for continued participation, or be requested to leave the event. In cases of extreme repeated behavior, an athlete or parent will be suspended for a specific period of time or removed from Special Olympics indefinitely.

***Please read through the rules and sign the form at the bottom.**

- Remain positive on the sidelines at all times. Yelling and/or coaching from the sidelines will not be allowed.
- Spectators will remain in the bleachers or observation areas. Respect the coaches' and official's decisions, regardless of whether or not you agree with them.
- If you have a question regarding any decision, please address the Head Coach. If you feel that the answer was not satisfactory, please call the Recreation Specialist.
- Respect all players on both teams. Rude comments toward teams, athletes, coaches or officials will not be tolerated.
- Profanity or abusive language will not be tolerated.
- Athlete must commit to attend all tournaments.
- Refrain from using alcohol, illegal drugs, and any other controlled substances.
- Special Olympics Illinois and The Village of Orland Park has a no tolerance policy in regard to physical altercations involving coaches, athletes, unified partners, volunteers, spectators, family member, etc.
- Refrain from using drugs for the purpose of improving the athlete's performance.
- Refrain from dating or having a relationship with any Special Olympics volunteer or staff member.

- Respect all Village of Orland Park facilities and equipment.
- Refrain from violent or disruptive behavior
- An understanding of the rules may lead to a more positive experience at events. All Special Olympics Illinois sports follow the designated National Governing Body (NGB) rules and any exceptions or modifications to those rules are included in the Special Olympics Illinois Rules Interpretations for the sport. A list of the designated NGB rules and the Rules Interpretations can be found at www.soill.org in the coach section.
- Keep in mind the Special Olympics oath and remember that winning is not the emphasis of Special Olympics competition.
- Coaches should be the ones to do the coaching. Please refrain from shouting instructions to athletes.
- ALL CHEERS should be positive and display good sportsmanship. Derogatory comments directed to players, coaches, and officials will not be tolerated.

Parent Signature:

Athlete Signature:

Date: _____

Date: _____

Phone: _____

By signing this document, you agree to adhere to the above codes of conduct and agree to the steps taken in case a code is broken.

Village of Orland Park Recreation Department



Coaches Code of Conduct

The primary purpose of this code of conduct is to ensure the safety and well-being of all athletes and coaches involved in our Special Olympics programs. All coaches must abide by this code for all sports in which they are involved.

Please understand that everyone involved in our sporting events must abide by these rules. Any coach not following the rules will be asked to remedy the situation for continued participation, or be requested to leave the event. In cases of extreme repeated behavior, a coach will be suspended for a specific period of time or removed from Special Olympics indefinitely.

All Special Olympics coaches must agree to the following codes:

- I will respect the rights, dignity and worth of athletes, coaches, other volunteers, friends and spectators in Special Olympics.
- I will treat everyone equally regardless of sex, ethnic origin, religion or ability.
- I will be a positive role model for the athletes I coach.
- I will ensure that for each athlete I coach, the time spent with Special Olympics is positive.
- I will respect the talent, developmental stage and goals of each athlete.
- I will ensure each athlete competes in events that challenge that athlete's potential and are appropriate to that athlete's ability.
- I will be fair, considerate and honest with athletes and communicate with athletes using simple, clear language.
- I will ensure that accurate scores are provided for entry of an athlete into any event.
- I will instruct each athlete to perform to the best of the athlete's ability at all preliminaries/heats and finals in accordance with Special Olympics Sports Rules.
- My language, manner, punctuality, preparation and presentation will demonstrate high standards.
- I will display control, respect, dignity and professionalism to all involved in the sport (athletes, coaches, opponents, officials, administrators, parents, spectators, media, etc.).
- I will encourage athletes to demonstrate the same qualities.

- I will not drink alcohol, smoke or take illegal drugs while representing Special Olympics at training sessions or during competition.
- I will refrain from any form of personal abuse towards athletes and others, including verbal, physical and emotional abuse. Special Olympics Illinois has a no tolerance policy in regard to physical altercations involving coaches, athletes, unified partners, volunteers, spectators, family members, etc.
- I will be alert to any form of abuse from other sources directed toward athletes in my care.
- I will not date or have a sexual relationship with any Special Olympics athlete. Please refer to the Volunteer/Athlete Dating Policy for complete details regarding this policy.
- I will seek continual improvement through performance evaluation and ongoing coach education.
- I will be knowledgeable about the Sports Rules and skills of the sport(s) I coach.
- I will provide a planned training program.
- I will keep copies of the medical, training, and competition records for each athlete I coach.
- I will follow the Special Olympics and the National Governing Body rules for my sport(s).
- I will ensure that the equipment and facilities are safe to use.
- I will ensure that the equipment, rules, training and the environment are appropriate for the age and ability of the athletes.
- I will review each athlete's medical form and be aware of any limitations noted on that athlete's participation form.
- I will encourage athletes to seek medical advice when required.
- I will maintain the same interest and support towards sick and injured athletes.
- I will allow further participation in training and competition only when appropriate

Coaches Signature:

Date: _____

Phone: _____

By signing this document, you agree to adhere to the above codes of conduct and agree to the steps taken in case a code is broken.

Appendix F – Forms

The forms used by the Village may change from time to time based on the law, staffing, or the needs of the departments or the Village.

Notification Forms may be completed by following Special Recreation Staff members

- Barb Rhodes at brhodes@orlandpark.org if it is for an inclusion participant
- Bridget McCormick at bmccormick@orlandpark.org if it is for a new participant registered for general programming/ overnights/ special events
- Nick Harvey at nharvey@orlandpark.org if it is for a new Special Olympics participant.

New Participants

New Special Recreation Participant Form
Initial Observation Report Form – Inclusion

Observation Form

Date: _____ Completed by: _____

Participant: _____ Disability: _____

Age: _____ Sex: _____ Agency/School: _____

Program: _____ Location: _____

Program day/time: _____ Number of participants present: _____

Concerns: _____

Ability Levels

I. Social Skills

a. *Communication*

_____	Verbally Independent	_____	Speech Impaired
_____	Maintains Good Eye Contact	_____	Sign Language
_____	Communication Aid		

Communicated and/or Interacts with: 1:1 Adults 1:1 Peers Small Group Large Group

Comments: _____

b. *Observations of Positive Interactions Exhibited (i.e. Communicating/Speaking to another, interaction with another participant, following directions, staying with the group, etc.) Indicate interaction, frequency, and duration.*

1. _____
2. _____
3. _____

c. *Observation of Negative Behavior(s) (i.e. spitting, hitting, etc.) Indicate interaction, frequency, and duration.*

1. _____
2. _____
3. _____

II. Physical Skills

_____ Physically Independent _____ Partially Mobile
_____ Mobility Aid Please indicate type: _____

Comments: _____

III. Cognitive Skills

_____ Can follow directions _____ Needs verbal prompting
_____ Responds to modeling _____ Needs physical prompting
_____ Needs step by step assistance

IV. Adaptations for Participation

_____ Can participate without adaptations
_____ May need adaptive equipment. Please explain: _____

Comments: _____

Action Plan

Indicate if there is a current plan in place: _____ If so, please attach and comment on progress below.

Indicate if a Team Meeting is needed: YES NO

Goal 1: _____
Action: _____

Goal 2: _____
Action: _____

Goal 3: _____
Action: _____

Special Recreation Coordinator Initials: _____

Signatures

Program Leader

Date

Staff Team

Date

DRAFT

2014 Annual Information Form (AIF)

This AIF must be completed and filed with the Department office, prior to the start of spring programs, in order for a participant to join any program or event. The AIF contains extremely important participant information which is necessary for Department staff to plan and execute safe and enjoyable programs. Please answer all questions in their entirety.

Date completed: _____

___ I do ___ I do not grant photo permission for registrant's picture to be used in Department publicity

Registrant Name: First: _____ Middle: _____ Last: _____

Sex: M ___ F ___ Date of Birth: ___/___/___ Weight: ___ Height: ___ Email: _____

Address: _____ City: _____ Zip: _____ Home Phone: _____

Parent/Guardian name: _____

Address (if different): _____ City _____ Zip _____

Mother's Work Phone: _____ Cell: _____

Father's Work Phone: _____ Cell: _____

Mother's Employer: _____ Father's Employer: _____

Primary Disability/Diagnosis: _____

School Attending/Other (Workshops, Daycare, Day Treatment): _____

Teacher's/ Supervisor's/Case Worker's Name: _____ Phone: _____

I authorize the Department to arrange for emergency medical treatment, in the event of an injury to my child, or me and in the event that I or my designated emergency contact cannot be reached by the Department.

Signature of Registrant, Parent, or Guardian

Date

Medical Information

Any participant needing to take medication during a program must sign a medical release form to allow staff to administer. Please call the Department in this regard at 123-456-7890.

1. Doctor's Name: _____ Doctor's Phone: _____

2. Medical Insurance Policy: Company Name: _____ Policy _____

3. Please list any medications the participant takes:

Medication	Dosage	Frequency
_____	_____	_____
_____	_____	_____
_____	_____	_____

4. Does registrant have allergies? Yes ___ No ___ If yes, please explain: _____

5. Is registrant subject to seizures? Yes ___ No ___ If yes, please explain: _____

6. Has registrant had any major accidents or injuries that could affect participation? Yes___ No___
If yes, please describe: _____

7. Are there any doctor's restrictions? Yes___ No___ If yes please describe: _____

8. Is the registrant a carrier of a chronic or communicable disease? Yes___ No___

Name of Disease: _____

9. Does registrant have Down syndrome? Yes___ No___ If no please go to question #10

If yes, has registrant been tested for atlanto-axial instability? Yes___ No___

If tested for atlanto-axial instability, were the results positive? Yes___ No___

10. Circle any devices participant may use/wear during games:

Contact Lenses Orthopedic Devices Dentures Glasses Hearing Aid Prosthesis

Other (Please Specify): _____

Mobility Information

11. Is registrant ambulatory? Yes___ No___

12. Does registrant use a wheelchair? Yes___ No___ Please Circle: Manual or Electric

13. Is the registrant willing to transfer? Yes___ No___ Please Explain: _____

14. Circle other assistive devices used for ambulation: Cane Walker Brace Crutches

Other, Please specify: _____

Dietary Needs

15. Does registrant have a specific diet, dietary restrictions, or any food that may cause behavioral change? Yes___ No___ If yes, please explain: _____

16. Is assistance needed in eating? Yes___ No___ If yes, please explain: _____

17. If registrant is over 21 years of age, can he/she consume alcohol? Yes___ No___ If yes, how much? _____

Safety

18. Please answer each of the following questions regarding the registrant as related to safety:

Willing to stay with group? Yes___ No___ Able to say name? Yes___ No___

Able to say phone #? Yes___ No___ Can manage own money? Yes___ No___

Can recognize danger? Yes___ No___ May wander or run? Yes___ No___

Can be held responsible for own belongings? Yes___ No___

Behavior/Personality

19. Describe the best way to get the registrant involved in an activity: _____

20. Describe any phobias/fears, e.g., fear of dogs, heights, confinement: _____

21. Describe any settings or activities that might cause behavior difficulties, e.g., noisy surroundings, airplanes, dance clubs, escalator, flashing lights, etc.? _____

22. Describe the best way to transition, introduce, or explain new tasks or transitioning? _____

23. Describe the types of situations that frustrate the registrant: _____

24. Describe the best way to redirect or engage the registrant's attention: _____

25. Is the registrant using a specific plan for behavior? Yes___ No___ If yes, please send a copy of the plan.

26. Does registrant act out? Yes___ No___ Please explain: _____

27. Describe type of behavior management or reinforcement that works best: _____

28. What type of additional assistance do you think the registrant might require to participate in a recreation setting? _____

Communication

29. Does registrant use sign language? Yes___ No___

30. Can registrant read and write? Yes___ No___

31. Specify other communication methods or needs: _____

Personal Care

32. Does registrant need assistance in the bathroom? Yes___ No___

33. Are regular bathroom times needed? Yes___ No___

34. Does registrant need other assistance, such as menstrual assistance? Yes___ No___ If yes, please elaborate: _____

Swimming

35. Does registrant swim? Yes___ No___ 36. Need a life jacket? Yes___ No___

37. Need 1:1 assistance in water? Yes___ No___ 38. Need assistance in dressing? Yes___ No___

**AUTHORIZATION TO
CONTACT AND RELEASE
INFORMATION**

Unless otherwise indicated in writing, I grant permission to the Village of Orland Park Recreation Department to contact school, teacher assistants, teacher, social worker, therapist or physician for the purpose of gathering or releasing information regarding the registrant. The information will be used to provide the most effective plan for providing Department services and supports. All information will be kept confidential.

Signature Registrant, Parent, or Guardian

Date

Seizure Form
Village of Orland Park Support Notification Form

Name of Participant: _____ DOB: _____

Parent/Guardian Name: _____ Phone: _____

Address: _____ City: _____ Zip: _____

1. Name of Program: _____

2. Program Supervisor: _____

3. Name of Instructor: _____

4. Day(s): _____ Date(s): _____

5. Time: _____

6. Location: _____ Room #: _____ Season: _____

7. Number of Participants Enrolled: _____ Staff/Participant Ratio: _____

8. No Program Date(s): _____

9. Class Prerequisites: Yes / No (specify): _____

10. Equipment/Supplies Needed: _____

11. Staff Contacted Family on (Date): _____

12. Comments on Conversation with the Parents: _____

13. Please indicate type of assistance requested:

Training _____ Observation _____ Companion _____ Modified Equipment _____

This form must be returned to the Department office in order to properly support the program and accommodate the registrant. It may also be emailed to

Completed by: _____ Date: _____

Support Note

Date: _____ Number of Pages: _____

To: _____

Staff: _____

Fax #: _____

From: _____

Notification Confirmation

Participant: _____

Program: _____

Days: _____ Times: _____

Dates: _____ No Program: _____

Comments: _____

New Registrant Assessment

Date: _____ Completed by: _____

Registrant's Name: _____

Parent/Guardian Name: _____

Address: _____

Home Phone: _____ Alternate Phone: _____

DOB: _____ Disability/Diagnosis: _____

A. Recreation Needs:

Interests: _____

Goals: _____

Support Needs: _____

B. Current Services:

Name/Address of School/Agency: _____

Contact Person/Teacher: _____

May we contact the above person to gain additional information? YES NO

C. Physical Support:

Ambulatory: YES NO

Uses assistive devices for ambulation? YES NO

Describe any special needs, restriction, limitation or precautions.

D. Social Support:

Verbally independent: YES NO _____

Maintains good eye contact: YES NO _____

Communication Aid: YES NO _____

Speech Impaired: YES NO _____

Sign Language: YES NO _____

E. Behavior Support:

Behavior management techniques being used:

Describe any recent outbursts/incidents:

Reinforcement techniques:

What causes/triggers behaviors?:

F. Emotional Support:

What makes you/dependent happy?:

What causes sadness/upset feelings?:

What helps to improve mood?:

Skills exhibited/likes:

Skills to develop/dislikes:

G. Other:

Toileting skills: _____

Feeding skills/dietary restrictions: _____

Allergies: _____

Seizures: _____

Individualized Support Plan

Name: _____ Family Member: _____ IIP Date: _____

Program: _____ Agency: _____

Dates/Days: _____ Times: _____

Present Level of Performance:

1

Goal: _____

Action Steps: _____

Techniques: _____

Adaptations/Environmental Considerations: _____

Duration: _____ to _____ Staff Responsible: _____

2

Goal: _____

Action Steps: _____

Techniques: _____

Adaptations/Environmental Considerations: _____

Duration: _____ to _____ Staff Responsible: _____

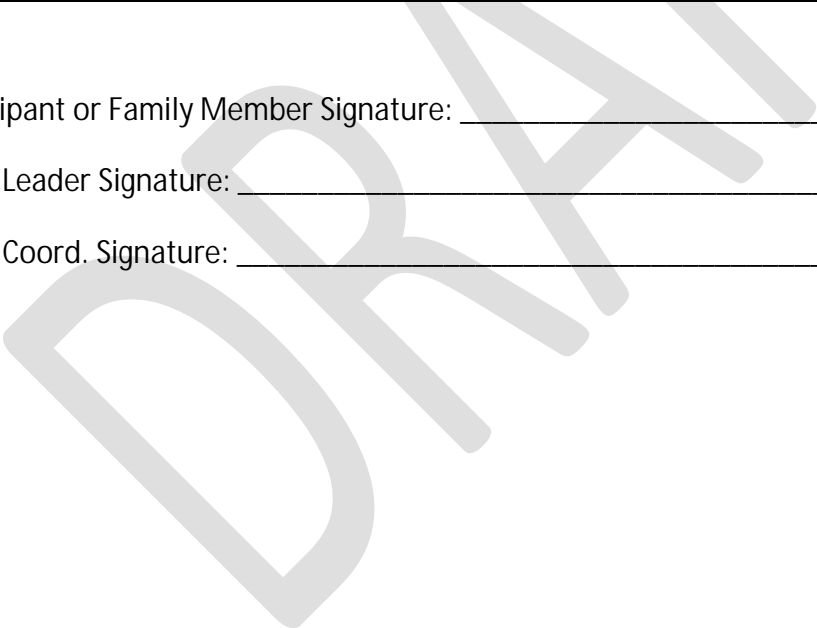
3

Goal: _____ _____ _____
Action Steps: _____ _____ _____
Techniques: _____
Adaptations/Environmental Considerations: _____
Duration: _____ to _____ Staff Responsible: _____

Participant or Family Member Signature: _____ Date: _____

Dept. Leader Signature: _____ Date: _____

Dept. Coord. Signature: _____ Date: _____



Code of Conduct Ideas

- 1) **Staff** will respect the rights of participants in all programs.
- 2) **Staff** will respect the property of participants in all programs.
- 3) **Staff** will treat each registrant, visitor, observer, participant, and guest with dignity.
- 4) **Staff** will speak and act with respect towards participants in all programs.
- 5) **Staff** will communicate to all registrants the expected conduct in each program.
- 6) **Staff** will protect the right to privacy of participants in all programs.
- 7) **Staff** will ask registrants for guidance in the ways Department programs can be made more enjoyable.
- 8) **Staff** will carefully implement planned supports for persons with disabilities.
- 9) **Staff** will ensure a safe and enjoyable experience at Department sites, facilities, and programs.

- 10) **Participants** will communicate openly with staff and when assistance is needed, will ask staff directly.
- 11) **Participants** will respect the rights of others in programs.
- 12) **Participants** will respect the property and equipment of others in programs.
- 13) **Participants** will respect the property and equipment of the Department.
- 14) **Participants** will adhere to the expected conduct in programs, with supports when necessary in regard the registrant's disability.
- 15) **Participants** will not pose a direct threat of imminent physical harm to other registrants, observers, staff, and volunteers in Department programs.
- 16) **Participants** will listen to the advice of staff and discuss feelings, concerns, and issues related to behavior.

Recommended items for the Special Recreation Policy Handbook as well as the Recreation Department Recreation Employee Handbook.



Village of Orland Park Recreation Department

2015 Annual Information Form (AIF)

This AIF must be completed and filed with the Recreation Department office prior to the start of Winter 2016 programs in order for a participant to join any program or event. The AIF contains extremely important participant information which is necessary for department staff to plan and execute safe and enjoyable programs. Please answer all questions in their entirety.

Date completed: _____
Registrant Name: First: _____ Middle: _____ Last: _____
Sex: M___ F___ Date of Birth: ___/___/___ Weight: ___ Height: ___ Email: _____
Address: _____ City: _____ Zip: _____
Home Phone: _____ Cell Phone: _____
Parent/Guardian name: _____
Address (if different): _____ City _____ Zip _____
Mother's Work Phone: _____ Cell: _____
Father's Work Phone: _____
Cell: _____
Mother's Employer: _____ Father's Employer: _____
Primary Disability/Diagnosis: _____
School Attending/Other (Workshops, Daycare, Day Treatment): _____
Teacher's/ Supervisor's/Case Worker's Name: _____ Phone: _____
I authorize the department to arrange for emergency medical treatment in the event of an injury to myself or my child, and in the event that I, or my designated emergency contact, cannot be reached by the department.

Signature of Registrant, Parent, or Guardian Date

Medical Information

Any participant needing to take medication during a program must sign a medical release form to allow staff to administer. Please call the department in this regard at 708-403-7275.

1. Doctor's Name: _____ Doctor's Phone: _____
2. Medical Insurance - Company Name: _____ Policy _____
3. Please list any medications the participant takes:

Medication	Dosage	Frequency
_____	_____	_____
_____	_____	_____
_____	_____	_____

4. Does registrant have allergies? Yes___ No___ If yes, please explain: _____

5. Is registrant subject to seizures? Yes___ No___ If yes, please explain: _____
6. Has registrant had any major accidents or injuries that could affect participation? Yes___ No___
If yes, please describe: _____
7. Are there any doctor's restrictions? Yes___ No___ If yes please describe: _____
8. Is the registrant a carrier of a chronic or communicable disease? Yes___ No___
Name of Disease: _____
9. Does registrant have Down syndrome? Yes___ No___ If no please go to question #10
If yes, has registrant been tested for atlanto-axial instability? Yes___ No___
If tested for atlanto-axial instability, were the results positive? Yes___ No___
10. Circle any devices participant may use/wear during games:
Contact Lenses Orthopedic Devices Dentures Glasses Hearing Aid Prosthesis
Other (Please Specify): _____

Mobility Information

11. Is registrant ambulatory? Yes___ No___
12. Does registrant use a wheelchair? Yes___ No___ Please Circle: Manual or Electric
13. Is the registrant willing to transfer? Yes___ No___ Please Explain: _____
14. Circle other assistive devices used for ambulation: Cane Walker Brace Crutches
Other, Please specify: _____

Dietary Needs

15. Does registrant have a specific diet, dietary restrictions, or any food that may cause behavioral change? Yes___ No___ If yes, please explain: _____
16. Does registrant have any swallowing precautions? Yes___ No___ If yes, please explain: _____
17. Is assistance needed in eating? Yes___ No___ If yes, please explain: _____
18. If registrant is over 21 years of age, can he/she consume alcohol? Yes___ No___ If yes, how much? _____

Safety

19. Please answer each of the following questions regarding the registrant as related to safety:
Willing to stay with group? Yes___ No___ Able to say name? Yes___ No___
Able to say phone #? Yes___ No___ Can manage own money? Yes___ No___
Can recognize danger? Yes___ No___ May wander or run? Yes___ No___
Can be held responsible for own belongings? Yes___ No___

Behavior/Personality

20. Describe the best way to get the registrant involved in an activity: _____
21. Describe any phobias/fears, e.g., fear of dogs, heights, confinement: _____
22. Describe any settings or activities that might cause behavior difficulties, e.g., noisy surroundings, airplanes, dance clubs, escalator, flashing lights, etc.? _____
23. Describe the best way to transition, introduce, or explain new tasks or transitioning? _____
24. Describe the types of situations that frustrate the registrant: _____

25. Describe the best way to redirect or engage the registrant's attention: _____

26. Is the registrant using a specific plan for behavior? Yes___ No___ If yes, please send.

If yes, please describe: _____

27. Does registrant act out? Yes___ No___ Please explain: _____

28. Describe type of behavior management or reinforcement that works best: _____

29. What type of additional assistance do you think the registrant might require to participate in a recreation setting? _____

Communication

30. Does registrant use sign language? Yes___ No___

31. Can registrant read and write? Yes___ No___

32. Specify other communication methods or needs: _____

Personal Care

33. Does registrant need assistance in the bathroom? Yes___ No___ If Yes, please provide specifics to assistance: _____

34. Are regular bathroom times needed? Yes___ No___

35. Does registrant need other assistance, such as menstrual assistance? Yes___ No___ If yes, please elaborate: _____

Swimming

36. Does registrant swim? Yes___ No___

37. Need a life jacket? Yes___ No___

38. Need 1:1 assistance in water? Yes___ No___

39. Need assistance in dressing? Yes___ No___

*Please note: If participant is subject to seizures, please fill out the Seizure Information Form available at both of our Recreation Offices, 708-403-7275 or 708-645-7529.

**AUTHORIZATION TO
CONTACT AND RELEASE
INFORMATION**

Unless otherwise indicated in writing, I grant permission to the Village of Orland Park Recreation Department to contact school, teacher assistants, teacher, social worker, therapist or physician for the purpose of gathering or releasing information regarding the registrant. The information will be used to provide the most effective plan for providing department services and supports. All information will be kept confidential.

Signature Registrant, Parent, or Guardian

Date



Village of Orland Park Recreation Department

2015 Annual Information Form (AIF)

This AIF must be completed and filed with the Recreation Department office prior to the start of winter 2016 programs in order for a participant to join any program or event. The AIF contains extremely important participant information which is necessary for department staff to plan and execute safe and enjoyable programs. Please answer all questions in their entirety.

Date completed: _____
Registrant Name: First: _____ Middle: _____ Last: _____
Sex: M___ F___ Date of Birth: ___/___/___ Weight: ___ Height: ___ Email: _____
Address: _____ City: _____ Zip: _____
Home Phone: _____ Cell Phone: _____
Parent/Guardian name: _____
Address (if different): _____ City _____ Zip _____
Mother's Work Phone: _____ Cell: _____
Father's Work Phone: _____ Cell: _____
Mother's Employer: _____ Father's Employer: _____
Primary Disability/Diagnosis: _____
School Attending/Other (Workshops, Daycare, Day Treatment): _____
Teacher's/ Supervisor's/Case Worker's Name: _____ Phone: _____

I authorize the department to arrange for emergency medical treatment in the event of an injury to myself or my child, and in the event that I, or my designated emergency contact, cannot be reached by the department.

Signature of Registrant, Parent, or Guardian Date

Medical Information

Any participant needing to take medication during a program must sign a medical release form to allow staff to administer. Please call the department in this regard at 708-403-7275.

1. Doctor's Name: _____ Doctor's Phone: _____
2. Medical Insurance - Company Name: _____ Policy _____
3. Please list any medications the participant takes:

Medication	Dosage	Frequency
_____	_____	_____
_____	_____	_____
_____	_____	_____

4. Does registrant have allergies? Yes___ No___ If yes, please explain: _____

5. Is registrant subject to seizures? Yes___ No___ If yes, please explain: _____

6. Has registrant had any major accidents or injuries that could affect participation? Yes___ No___
If yes, please describe: _____
7. Are there any doctor's restrictions? Yes___ No___ If yes please describe: _____

8. Is the registrant a carrier of a chronic or communicable disease? Yes___ No___
Name of Disease: _____
9. Does registrant have Down syndrome? Yes___ No___ If no please go to question #10
If yes, has registrant been tested for atlanto-axial instability? Yes___ No___
If tested for atlanto-axial instability, were the results positive? Yes___ No___
10. Circle any devices participant may use/wear during games:
Contact Lenses Orthopedic Devices Dentures Glasses Hearing Aid Prosthesis
Other (Please Specify): _____

Mobility Information

11. Is registrant ambulatory? Yes___ No___
12. Does registrant use a wheelchair? Yes___ No___ Please Circle: Manual or Electric
13. Is the registrant willing to transfer? Yes___ No___ Please Explain: _____
14. Circle other assistive devices used for ambulation: Cane Walker Brace Crutches
Other, Please specify: _____

Dietary Needs

15. Does registrant have a specific diet, dietary restrictions, or any food that may cause behavioral change? Yes___ No___ If yes, please explain: _____

16. Does registrant have any swallowing precautions? Yes___ No___ If yes, please explain: _____

17. Is assistance needed in eating? Yes___ No___ If yes, please explain: _____

18. If registrant is over 21 years of age, can he/she consume alcohol? Yes___ No___ If yes, please define the type and limit. _____

Safety

19. Please answer each of the following questions regarding the registrant as related to safety:
- Willing/able to stay with group when directed? Yes___ No___
 - May wander or run? Yes___ No___
 - Able to say name? Yes___ No___
 - Able to say phone number? Yes___ No___
 - Can manage own money? Yes___ No___
 - Can be held responsible for own belongings? Yes___ No___
 - Can recognize danger (traffic, fire, icy conditions, deep water etc.)? Yes___ No___

Behavior/Personality

20. Describe the best way to get the registrant involved in an activity: _____

21. Describe any phobias/fears, e.g., fear of dogs, heights, confinement: _____

22. Describe any settings or activities that might cause behavior difficulties, e.g., noisy surroundings, airplanes, dance clubs, escalator, flashing lights, etc.? _____

23. Describe the best way to transition, introduce, or explain new tasks or transitioning? _____

24. Describe the types of situations that frustrate the registrant: _____

25. Describe the best way to redirect or engage the registrant's attention: _____

26. Does registrant display any negative behaviors? Yes___ No___ Please explain: _____

27. Is the registrant using a specific plan for behavior? Yes___ No___
 If yes, please provide a copy attached to this form.
28. Describe type of behavior management or reinforcement that works best: _____

29. What type of additional assistance do you think the registrant might require to participate in a recreation setting _____

Communication

30. Does registrant use sign language as a primary means of communication? Yes___ No___
31. Can registrant read? Yes___ No___ Can registrant write? Yes___ No___
32. Specify other communication methods or needs: _____

Personal Care

33. Does registrant need assistance in the bathroom? Yes___ No___ If Yes, please provide specific instructions for assistance: _____

34. Are regular bathroom times needed? Yes___ No___
35. Does registrant need other assistance, such as menstrual assistance? Yes___ No___ If yes, please provide specific instructions for assistance: _____

Swimming

36. Does registrant swim independently? Yes ___ No___
37. Does the registrant require a life jacket? Yes___ No___
38. Does the registrant need 1:1 assistance in water? Yes ___ No___
39. Does the registrant need assistance dressing? Yes___ No___

AUTHORIZATION TO CONTACT AND RELEASE INFORMATION

Unless otherwise indicated in writing, I grant permission to the Village of Orland Park Recreation Department to contact school, teacher assistants, teacher, social worker, therapist or physician for the purpose of gathering or releasing information regarding the registrant. The information will be used to provide the most effective plan for providing department services and supports. All information will be kept confidential.

Signature Registrant, Parent, or Guardian

Date

The Village of Orland Park Recreation Department



September 2015

To all parents, guardians and participants of the Village of Orland Park Special Recreation Programs,

The Village of Orland Park Recreation Department Special Recreation Division has revamped their Annual Health Form. It will be replaced with the Annual Information Form. This form must be filled out prior to the start of Winter/Spring programs in January 2016.

The deadline for all new Annual Information Forms is January 2, 2016.

The Annual Information Form will include updates in the following areas listed below:

1. Contact Information
2. Medical Information
3. Mobility Information
4. Dietary Needs
5. Safety
6. Behavior/Personality
7. Communication
8. Personal Care
9. Swimming/ Aquatic Safety

This form will be available at both registration offices at Sportsplex and Recreation Administration and online.

In conjunction with the Annual Information Form, you will also be required to fill out a Seizure Information Form if applicable.

Please note that we must have all updated forms in our possession before a participant can partake in Winter/Spring 2016 programs.

Thank you,

Kathleen Hellwig
Special Recreation Program Supervisor

Incident/Accident Documentation Checklist



Purpose

The purpose of the Incident/Accident Documentation Checklist is to assist staff in following the proper administrative procedures in the event of an incident or accident. The checklist must be reviewed and completed with all other appropriate documentation and submitted to the Recreation Program Supervisor within 24 hours of the incident.

Please mark off the following actions/ for emergency purposes

- Administered 1st Aid
 - EMS (police, fire, ambulance) was contacted
 - Parents and/or guardians were notified
 - Incident Report completed (used when participant is injured)
 - Accident Report completed (used when staff member is injured)
 - Contacted Program Supervisor
-

All appropriate forms (i.e. Incident Report Form, Accident Report Form, Incident/Accident Documentation Checklist, and Support Note) need to be turned in with in 24 hour period after incident.

Name of Participant or Employee involved in incident: _____

Special Recreation Staff Signature: _____

Date: _____

Supporting notes regarding documentation:

VILLAGE OF ORLAND PARK RECREATION DEPARTMENT
PROGRAM MEDICATION AUTHORIZATION FORM



If your participant takes medication, please read and complete this form in its entirety.

PARTICIPANT'S NAME _____ BIRTH DATE _____

ADDRESS _____ CELL PHONE _____

HOME PHONE _____

EMERGENCY PHONE NUMBERS

_____ (RELATION TO PARTICIPANT)

_____ (RELATION TO PARTICIPANT)

PROGRAM NAME _____

- Medication will not be dispensed without a signed Medication Form.
- Medicine **must** be sent in single doses, each in its own sealed envelope.
- The medication information below must be printed on each envelope.
- Please list all prescriptions that will need to be taken daily as well as over the counter medications.

To be completed by the participant/parent/guardian:

	FIRST MEDICATION	SECOND MEDICATION	THIRD MEDICATION
Name of Medication	_____	_____	_____
Dose and Quantity	_____	_____	_____
Prescription Number	_____	_____	_____
Pharmacy Name	_____	_____	_____
Pharmacy Number	_____	_____	_____
Time to Administer	_____	_____	_____
Special Instruction	_____	_____	_____
Doctor's Name	_____	_____	_____
Doctor's Phone Number	_____	_____	_____

I hereby authorize the Village of Orland Park and its employees and agents, in my behalf and stead, to administer or attempt to administer to said program participant (or to allow participant to self-administer, while under the supervision of the employees of the Village of Orland Park Recreation Program), lawfully prescribed medication in the manner described above during the program. I ACKNOWLEDGE THAT IT MAY BE NECESSARY FOR THE ADMINISTRATION OF MEDICATION TO THE PARTICIPANT TO BE PERFORMED BY AN INDIVIDUAL OTHER THAN A NURSE OR HEALTH AIDE (i.e. COUNSELOR), AND SPECIFICALLY CONSENT TO SUCH PRACTICE. I further acknowledge and agree that, when lawfully prescribed medication is so administered or attempted to be administered, I waive any claims I might have against the Village of Orland Park, its employees and agents arising out of the administration of said medication. In addition, I agree to hold harmless and indemnify the Village of Orland Park, its employees and agents, either jointly or separately, from and against any and all claims, damages, causes of action or injuries incurred or resulting from the administration or attempts at administration of said medication.

Participant/Parent/Guardian Signature: _____ Date _____

Seizure Information Form



This form should be completed in its entirety for emergency purposes.

In the event that your child has a seizure, the staff requires having the most up to date information to assist in the proper care.

Name: _____ Date: _____

Form Completed by: _____ Relationship: _____

1. How frequent do seizures occur? _____
2. Please describe the characteristics of the seizures:

3. What is the usual duration of seizure? _____
4. When do seizures normally occur? _____
5. Are there any sign/ trigger/ warning to the seizure?

6. Please describe the participant reaction after a seizure:

7. Please explain what actions to take in the event of a seizure:

8. What medication is the participant currently taking?

9. Are there side effects to the medicine? _____
 - a. If so, what are they? _____
10. In the event of a seizure you will be notified. Please list all contacts:
 - a. Name: _____ Number: _____
 - b. Name: _____ Number: _____
 - c. Name: _____ Number: _____

Please indicate any specifics regarding any conclusive medical concerns.

In the event that a participant has a grand mal seizure, 911 will be called.

Parent Signature:

_____ Date: _____



Individualized Support Plan

Name: _____ Family Member: _____ Date: _____

Program: _____ Agency: _____

Dates/Days: _____ Times: _____

Present Level of Performance:

1

Goal: _____

Action Steps: _____

Techniques: _____

Adaptations/Environmental Considerations: _____

Duration: _____ to _____ Staff Responsible: _____

2

Goal: _____

Action Steps: _____

Techniques: _____

Adaptations/Environmental Considerations: _____

Duration: _____ to _____ Staff Responsible: _____

3

Goal:

Action Steps:

Techniques:

Adaptations/Environmental Considerations:

Duration: _____ to _____ Staff Responsible: _____

Participant or Family Member Signature: _____ Date: _____

Special Recreation Staff: _____ Date: _____

Special Recreation Program Supervisor
Signature: _____ Date: _____



Individualized Support Progress

Name: _____ Reference Support Plan Dated: _____

Program(s): _____

1

Goal Progress:

Action Steps:

Techniques: _____

Adaptations/Environmental Considerations: _____

Duration: _____ to _____ Staff Responsible: _____

2

Goal Progress:

Action Steps:

Techniques: _____

Adaptations/Environmental Considerations: _____

Duration: _____ to _____ Staff Responsible: _____

3

Goal Progress: _____

Action Steps: _____

Techniques: _____

Adaptations/Environmental Considerations: _____

Duration: _____ to _____ Staff Responsible: _____

Special Recreation Staff Signature: _____ Date: _____

Special Recreation Program Supervisor Signature: _____ Date: _____

Participant or Family Member Signature: _____ Date: _____
(Signature verifies receipt of this document)

Family Member Comments: _____



Individualized Support Note

Participant's name:

JohnSmith Program: Bright Dates/Days:
Times: _____

Communication with Parent/ Guardian

Email: _____ / / Phone: _____ / / Fax: _____ / /

Text Message: _____ / / Scanned and Sent Document: _____ / /

Response from Parent/ Guardian Yes/ No (circle one)

Spoke to _____ / /

Phone Message: / / / / / /

Email: / / / / / /

Purpose of Communication

Notification/ Verification of Services: _____ / / / /

Observation Report: _____ / / / /

Assessment Report: _____ / / / /

Annual Information Form: _____ / / / /

Seizure Form: _____ / / / /

Medical Application Form: _____ / / / /

Overnight Form: _____ / / / /

Comments/ Narrative of Conversation:

Follow Up Actions/ Response:

Village of Orland Park Recreation Department
Special Recreation Division
Inclusion Observation Report

Program Name: _____ Number: _____

Participant: _____

Social Skills

Communication

Speech

- ___ Uses and recognizes words by self, makes complete thoughts, clear speech
- ___ Needs verbal prompts to complete thoughts, mumbled speech
- ___ Dependent on a device to communicate with others

Body language

- ___ Maintains eye contact and has good posture when communicating
- ___ Maintains eye contact 50% and has trouble staying in one place while conversing
- ___ Maintains eye contact $\geq 10\%$ and poor body posture, turns back when not listening

Inference

- ___ Understands conversations and can use information to help solve problems
- ___ Limited understanding of conversations, needs constant reminder to redirect, can solve a problem with help from peer or staff
- ___ No understanding at all, needs direct support to process information, can only solve two or less problems by self

Involvement

Peer interaction

- ___ Start/Finish conversations with fellow peers, listens to directions exceeding average
- ___ Introduced into conversations by another peer, sometimes has delay when speaking, average listening skill
- ___ Does not start conversations unless called on by staff, mainly talks with staff, shy towards peers

Groups

- ___ Follows and stays with group, whether large or small
- ___ Follows and stays with group with help of 1:1 staff in both small and large
- ___ Needs to be assisted in group, elopes whenever possible (should never be left alone)

Behaviors

Positive Behaviors

List any and all behaviors observed

Negative Behaviors

List any and all behaviors observed

Physical Skills

Mobility

Student can ambulate to designated area by self, 100% of the time

Student can ambulate to designated area by self, 50% of the time

Student needs help to be directed to designated area

Assistive Device

Does the student have a walker, wheelchair, or other device to assist with movement throughout an area?

Circle: Y or N

Cognitive Skills

Directions

Student follows directions with minimal assistance from staff

Student follows directions with at least 2 gestural prompts

Student follows directions with at least 2 verbal prompts

Student doesn't follow directions, responds slowly, needs personal assistance

Comments

If there was anything else that may have contributed to the report being conducted, (medication change, peer separation, substitute staff didn't know their program) please record that down below in the section provided.

Special Recreation Staff

Date

Special Recreation Supervisor

Date

Inclusion

When does a child need to be observed for inclusion services?

1. Child cries uncontrollable after at least 5-6 classes
2. Child exhibits aggressive behavior toward other children and staff
3. Child appears to have self-destructive behavior such as
 - a. Hitting other children or self repeatedly
 - b. Biting other children or staff
 - c. Head banging
4. Child appears to have physical limitations
 - a. Gross and fine motor delays
 - b. Visual and/ or hearing impairments
5. Child demonstrates extreme hyperactivity
 - a. Flapping arms repeatedly
 - b. Running around the room constantly
 - c. Bolting out of a room
 - d. Extreme impulsiveness
6. Child demonstrates extreme delay
 - a. Poor trunk mobility
 - b. Poor awareness of body structure
 - c. Poor left or right side neglect
 - d. Inability to track with vision control
7. Child demonstrates severe anxiety
 - a. Obsessive nail biting
 - b. Consistent bathroom accidents
 - c. Over occurrences of vomiting
 - d. Repetitive movements/ ritualistic behavior
8. Child proficient in profanity
 - a. Possible-Opposition defiant disorder
9. Child that demonstrates severe tactile defense

Village of Orland Park Recreation Department
Special Recreation Division
Observation Request Form

Authorized by: (Supervisor) _____ Date: _____

Participant: _____ Age: _____ Sex: M / F

Program: _____ Location: _____

Program Date: _____ to _____ Number of Participants present: _____

Number of participants registered: _____

Reason for observation request:

Observation Date: _____ Completed by: _____

Concerns:

Village of Orland Park Recreation Department
Special Recreation Division
Observation Request Form

Authorized by: (Supervisor) _____ Date: _____

Participant: _____ Age: _____ Sex: M / F

Program: _____ Location: _____

Program Date: _____ to _____ Number of Participants present: _____

Number of participants registered: _____

Reason for observation request:

Observation Date: _____ Completed by: _____

Concerns:

Village of Orland Park Recreation Department
Special Recreation Division

Checklist for Inclusive Services

- Head Instructor/Teacher/Leader notices a client in need of personal attention that cannot be provided by themselves or other instructors.
- Instructor contacts their supervisor and requests additional support.
- Supervisor agrees to observe program to justify means of requesting additional support for program.
- If Supervisor agrees to request additional support, the observation will be scheduled.
- Supervisor contacts Special Recreation Supervisor by using an observation request form.
- Before the observation is conducted, a meeting may be assigned between the observation team and the program's leader and supervisor, to discuss what actions were taken in the past when these behaviors surmounted.
- Special Recreation Supervisor receives the request form and assigns SR Staff to begin the observation process.
- Observation is scheduled and SR Staff watches over entire program and the client in question for services.
- SR Staff utilizes Inclusion Observation Report to document what has been seen or inferred upon.
- From those notes, the Special Recreation team discusses whether support is needed, forming this into an inclusion.
- The Special Recreation Supervisor will contact the Program Supervisor to confirm or deny their role in supporting the program.
- The Special Recreation Program Coordinator will contact the parent/guardian of the client and inquire about inclusive services to help make their child more successful in the program.
- Parent/Guardian may accept or deny the request for inclusive 1:1 services.
- If Parent/Guardian accepts, the aide will be implemented into the program.
- If Parent/Guardian denies, the Program Supervisor will be contacted by the Special Recreation team and explain that the parent has not agreed upon an aide.
- If the Parent/ Guardian have denied services, the SR Supervisor can provide inclusion support but is not obligated. However may encourage a Program Supervisor to obtain additional support to ensure the successfulness of the program and to assist the program instructor.



Individualized Support Progress

Name: _____ Reference Support Plan Dated: _____

Program(s): _____

1

Goal Progress:

Action Steps:

Techniques: _____

Adaptations/Environmental Considerations: _____

Duration: _____ to _____ Staff Responsible: _____

2

Goal Progress:

Action Steps:

Techniques: _____

Adaptations/Environmental Considerations: _____

Duration: _____ to _____ Staff Responsible: _____

3

Goal Progress: _____

Action Steps: _____

Techniques: _____

Adaptations/Environmental Considerations: _____

Duration: _____ to _____ Staff Responsible: _____

Special Recreation Staff Signature: _____ Date: _____

Special Recreation Program Supervisor Signature: _____ Date: _____

Participant or Family Member Signature: _____ Date: _____
(Signature verifies receipt of this document)

Family Member Comments: _____



Village of Orland Park Recreation Department – Special Recreation New Registrant Assessment

Date: _____ Completed by: _____

Registrant Name: _____

Parent/Guardian Name: _____

Address: _____

Home Phone: _____ Alternate Phone: _____

DOB: _____ Disability/Diagnosis: _____

A. Recreation Needs:

Interests: _____

Goals: _____

Support Needs: _____

B. Current Services:

Name/Address of School/Agency: _____

Contact Person/Teacher: _____

May we contact the above person to gain additional information? YES NO

C. Physical Support:

Ambulatory: YES NO

Uses assistive devices for ambulation? YES NO

Describe any special needs, restriction, limitation or precautions.

D. Social Support:

Verbally independent: YES NO _____

Maintains good eye contact: YES NO _____

Communication Aid: YES NO _____

Speech Impaired: YES NO _____

Sign Language: YES NO _____

E. Behavior Support:

Behavior management techniques being used:

Describe any recent outbursts/incidents:

Reinforcement techniques:

What causes/triggers behaviors?:

F. Emotional Support:

What makes you/dependent happy?:

What causes sadness/upset feelings?:

What helps to improve mood?:

Skills exhibited/likes:

Skills to develop/dislikes:

G. Other:

Toileting skills: _____

Feeding skills/dietary restrictions: _____

Allergies: _____

Seizures: _____

Staff: _____ Date: _____

DRAFT



Village of Orland Park Recreation Department – Special Recreation Observation Form

Authorized by: (parent or guardian) _____ Date: _____

Observation Date: _____ Completed by: _____

Participant: _____

Age: _____ Sex: _____

Program: _____ Location: _____

Program date/time: _____ Number of participants present: _____

Concerns:

Ability Levels

I. Social Skills

a. *Communication*

_____ Verbally independent

_____ Maintains good eye contact

_____ Communication aid

_____ Speech Impaired

_____ Sign Language

Communicated and/or Interacts with: 1:1 Adults 1:1 Peers Small Group Large Group

Comments: _____

b. *Observations of Positive Interactions Exhibited (i.e. Communicating/Speaking to another, interaction with another participant, following directions, staying with the group, etc.) Indicate interaction, frequency, and duration.*

1. _____

2. _____

3. _____

c. *Observation of Negative Behavior(s) (i.e. spitting, hitting, etc.) Indicate interaction, frequency, and duration.*

1. _____
2. _____
3. _____

II. Physical Skills

_____ Physically Independent _____ Partially Mobile
_____ Mobility Aid Please indicate type: _____

Comments: _____

III. Cognitive Skills

_____ Can follow directions _____ Needs verbal prompting
_____ Responds to modeling _____ Needs physical prompting
_____ Needs step by step assistance

IV. Adaptations for Participation

_____ Can participate without adaptations
_____ May need adaptive equipment. Please explain: _____

Comments: _____

Action Plan

Indicate if there is a current plan in place: _____ if so, please attach and comment on progress below:

Indicate if a Team Meeting is needed: YES NO

Goal 1: _____

Action: _____

Goal 2: _____

Action: _____

Goal 3: _____

Action: _____

Special Recreation Staff

Date

Special Recreation Program Supervisor

Date

DRAFT



Individualized Support Note

Participant's name: _____ Program: _____

Dates/Days: _____ Times: _____

Communication with Parent/ Guardian

Email: _____ / / Phone: _____ / / Fax: _____ / /

Text Message: _____ / / Scanned and Sent Document: _____ / /

Response from Parent/ Guardian Yes/ No (circle one)

Spoke to _____ / /

Phone Message: / / / / / /

Email: / / / / / /

Purpose of Communication

Notification/ Verification of Services: _____ / / / /

Observation Report: _____ / / / /

Assessment Report: _____ / / / /

Annual Information Form: _____ / / / /

Seizure Form: _____ / / / /

Medical Application Form: _____ / / / /

Overnight Form: _____ / / / /

Comments/ Narrative of Conversation:

Follow Up Actions/ Response:



Individualized Support Plan

Name: _____ Family Member: _____ Date: _____

Program(s): _____

Dates/Days: _____ Times: _____

Present Level of Performance:

1

Goal:

Action Steps:

Techniques: _____

Adaptations/Environmental Considerations: _____

Duration: _____ to _____ Staff Responsible: _____

2

Goal:

Action Steps:

Techniques: _____

Adaptations/Environmental Considerations: _____

Duration: _____ to _____ Staff Responsible: _____

3

Goal: _____

Action Steps: _____

Techniques: _____

Adaptations/Environmental Considerations: _____

Duration: _____ to _____ Staff Responsible: _____

Special Recreation Staff Signature: _____ Date: _____

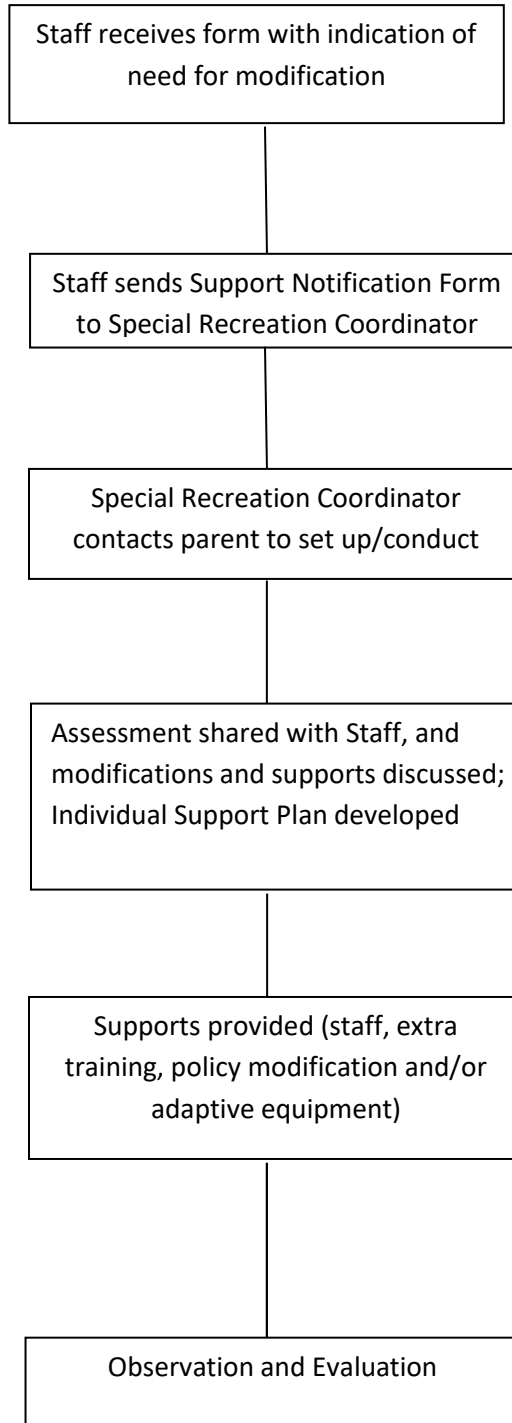
Special Recreation Program Supervisor Signature: _____ Date: _____

Participant or Family Member Signature: _____ Date: _____
(Signature verifies receipt of this document)

Family Member Comments: _____

SUPPORT PROCESS

PARENT/GUARDIAN MARKS “YES” ON REGISTRATION



Special Recreation Coordinator

Initial Parent/Guardian/Registrant Contact when Notification is on Registration

DRAFT SCRIPT FOR CALL OR EMAIL

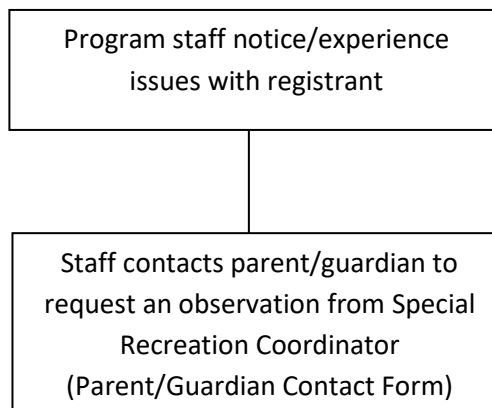
Hi, my name is _____, and I am on staff at the Village of Orland Park Recreation Department. In reviewing the program registration form, I see that you indicated a request for modification for yourself/registrant for the _____ program. Welcome to that program!

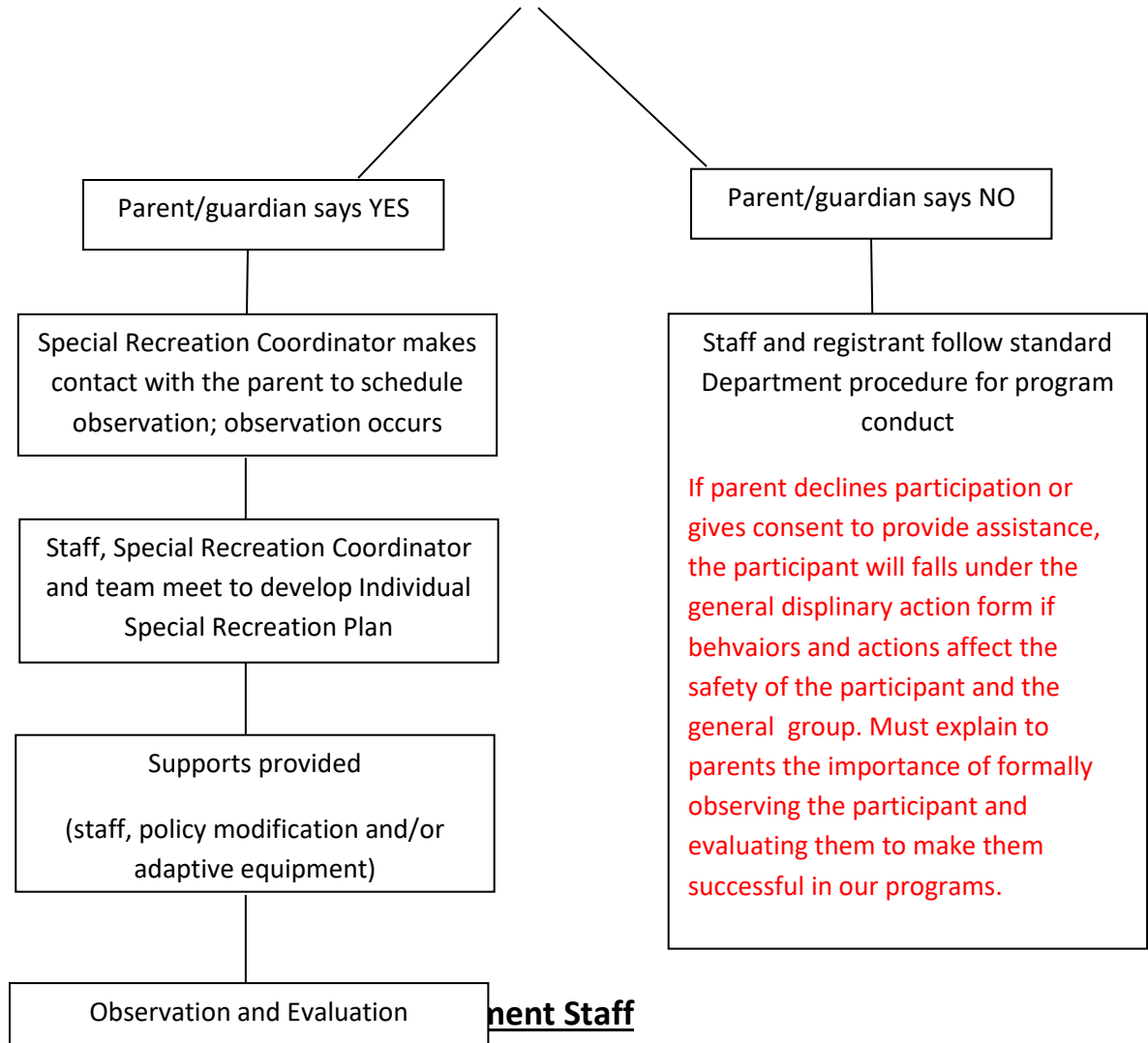
I am the Special Recreation Coordinator for the Department and would like to set up a time to complete an initial assessment so we can gather information that will help us to provide the best supports for _____ in the program.

If _____ is currently in another program, or in school, we can, with your permission, also conduct an observation of him/her in his/her current setting. Together with the assessment we can use the information to create an individualized plan.

What is most convenient for you, to complete the assessment over the phone, or would you prefer a face to face meeting? Would you like to schedule an observation at this time as well?

SUPPORT PROCESS PARENT/GUARDIAN/REGISTRANT MARKS “NO” ON THE REGISTRATION





Initial Parent/Guardian/Registrant Contact when Modification is Requested

Hi, my name is _____, and I am on staff at the Orland Park Parks and Recreation Department. I am contacting you to discuss your (self, son, daughter, etc...the registrant) within our program. Our goal is to have all registrants participate in safely and enjoyably. We want the registrant to have a successful experience with us.

1. List positive behaviors of the individual:

- i.e. makes friends easily, loves swimming, good sense of humor, etc.

2. List the concerns:

- The behaviors being seen in the program are _____. i.e. not following directions, refuses help from staff, difficulty switching to a new activity
- Discuss the structure of the program and let parent/guardian know when the negative behaviors are present. (i.e. at drop off, before lunchtime, when he/she is sitting next to Joe B)

3. Ask the parent/guardian for their input.

- Is registrant experiencing any of these behaviors at home or in other programs outside your home? What do you do when he/she displays these behaviors? Any suggestions would be helpful.
- Are there any changes any changes going on in his/her life? (i.e. sibling issues, family changes, divorce, parent on a business trip)

4. Let parent/guardian know that you will try the tip they provided, but may need extra help.

5. Through the Department we have the support of a Special Recreation Coordinator that can conduct an observation of the registrant and provide suggestions or adaptations. This may include providing extra staff for the program. Can we have your permission to schedule an observation with the Special Recreation Coordinator?

6. If you do not want Special Recreation staff involvement, there are fewer opportunities for us to make modifications that can assist the registrant to follow all Department policies and code of conduct.

Special Recreation Coordinator

Initial Parent/Guardian/Registrant Contact when Observation is Requested

Hi, my name is _____, and I am on staff with the Orland Park Parks and Recreation Department. I am contacting you because the Department staff has requested an observation for the _____ program.

We are specifically brought in to assist Department staff when a difficulty arises in programs. Program staff are concerned that your (son, daughter, etc.) is not succeeding in the program. We will go and observe the program on _____. After the program, feel free to talk with the staff who observed the program. Any other questions or concerns feel free to contact me at phone or email.

Possible Questions:

- Are there any there any other programs you are observing?
 - Staff calls us out on specific programs where they are having issues.

- Is it only my child/adult you are observing?
 - We are called out to observe the program as a whole and assess the needs in order for all the individuals to have a successful experience within the program. Program staff has raised some concerns about some of the behaviors they have been seeing within the program.
- What are the behaviors they are seeing?
 - The behaviors being seen in the program are (be specific).
- Why has the program staff not talked to me?
 - You will need to address that with the program staff after the program; however, the Department has requested us out to assess the program and work with the staff to make it successful.
- What do you need from me?
 - Can you tell me if you have seen or experienced any of these behaviors before either at home or in programs outside your home?

From section 4.4 - The Initial Contact script and the New Special Recreation Assessment Form to gather information.

See page **XX** for Initial Contact script by the Department program staff.

See page **XX** for Initial Contact script by the Special Recreation Coordinator

See pages **XX** earlier for the New Registrant Assessment Form.

When making a decision to temporarily remove a participant, it is extremely important that documentation has occurred throughout the process. Anytime the Village has to say “no” to someone on the basis of a disability; staff will create a Support Note outlining the request, why access was denied and the response of the individual. A confidential file will be created for these Support Notes.

In summary, when removing someone from a program, there should be a progression of memos or documentation of occurrences, consequences and corrective action that has led up to the decision. Keep in mind that permanent removal is not an option. However, there can be criteria that must be met before a participant can return to the program. This may involve evidence of behavioral change; new medication or new methods of behavioral modification proved successful by other professionals in the participant’s life.

Not applicable at this time/

<u>Support Staff</u>	
<u>Evaluation Form</u>	
Staff: _____	Date: _____
Program: _____	Evaluator: _____
<u>Scale System</u>	
0 = Not Applicable	
1 = Unsatisfactory	
2 = Room for Improvement	
3 = Average	
4 = Very Good	
5 = Excellent	

1. Staff demonstrated compliance with policies and procedures (i.e. adhered to rules, interacted with participants appropriately, was punctual, dressed appropriately, etc.) 0 1 2 3 4 5
Comments: _____

2. Staff provided assistance when requested, remained active throughout programs, supported and carried out staff decisions. 0 1 2 3 4 5
Comments: _____

3. Staff took initiative and worked independently, problem-solved situations, was able to ask for help, and accepted suggestions. 0 1 2 3 4 5
Comments: _____

4. Staff worked effectively and communicated with other staff, made efforts to be a team player, introduced new ideas, and appropriately advocated for participant's needs. 0 1 2 3 4 5
Comments: _____

5. Staff appeared poised, courteous, professional, flexible, and maintained a positive attitude. 0 1 2 3 4 5

Comments: _____

6. Staff was friendly, cooperative, demonstrated energy and enthusiasm about the program, participant, and inclusion. 0 1 2 3 4 5

Comments: _____

7. Staff possessed knowledge and information about the placement, came prepared for work, and was able to fulfill job requirements. 0 1 2 3 4 5

Comments: _____

8. Staff successfully redirected inappropriate behaviors and correctly implemented behavior plan as instructed. 0 1 2 3 4 5

Comments: _____

9. Staff demonstrated positive interactions with participant as well as anticipated and responded to specific needs and problems as they arise. 0 1 2 3 4 5

Comments: _____

10. Staff effectively communicated to the participant regarding expected and appropriate behavior. 0 1 2 3 4 5

Comments: _____

11. Staff encouraged participant to become actively involved in the program activities, and helped to foster peer interactions. 0 1 2 3 4 5

Comments: _____

12. Staff effectively communicated with the family regarding the inclusion placement. 0 1 2 3 4 5

Comments: _____

<p>Employee's strengths:</p> <p>_____</p> <p>_____</p> <p>_____</p> <p>Areas needing improvement:</p> <p>_____</p> <p>_____</p> <p>_____</p> <p>Recommendation for future employment:</p> <p>_____</p> <p>_____</p> <p>_____</p>
--

Staff: _____ Date: _____

Evaluator: _____ Date: _____

Manager: _____ Date: _____

Special Recreation/Inclusion Support Staff Responsibilities

1. To The Registrant:

- A. Be courteous and respectful to the individuals with disabilities.
- B. Be aware at all times of the location of the registrant you are assigned to work with.
- C. Arrive 15 minutes early to your assigned program.
- D. Do not share personal information about the included individual outside of work.
- E. Encourage and foster independence.
- F. Use only approved behavior management techniques.
- G. Attend to the person needs of the individual (toileting, feeding).
- H. Let the registrant speak for him/herself whenever possible.
- I. Assist the registrant with transitions from one activity to another.
- J. Facilitate and promote social interactions and friendships.

- K. Repeat the instructor's directions when necessary.
- L. Be an advocate for full inclusion by ensuring equal access to all activities, and adaptation of activities.

2. To The Support Team

- A. Read the inclusion or special recreation materials thoroughly, prior to starting your job.
- B. Contact the Special Recreation Coordinator as early as possible, whenever sick or unable to attend an assigned program.
- C. Share any problems/concerns with the Inclusion Support Team.
- D. Complete evaluation forms by the given deadline.

3. To The Program Instructor/Village of Orland Park Staff

- A. Contact the program instructor/support staff as soon as possible when sick or unable to attend the program. Unexcused absences will result in a negative impact on the program and the registrant.
- B. Keep the instructor informed of any problems or concerns that occur during the program.
- C. Arrive 15 minutes early to your assigned program.
- D. Follow all procedures of the program.
- E. Attend all planning meetings or orientation sessions.
- F. Introduce yourself to the instructor as a Support Staff.
- G. Assist the instructor with preparation/clean-up, when necessary.
- H. Dress appropriately for the program and be prepared to participate.
- I. If the included registrant is interacting well with other registrants, and if the Inclusion Support Staff is asked to assist in performing other duties, he or she may do so if it does not jeopardize the safety of the included registrant.

4. Supervision

- A. As an Inclusion Support Staff, you are also a Village of Orland Park staff; therefore while you are at your placement, your immediate supervisor is the program instructor.
- B. The Special Recreation Coordinator will be an offsite supervisor.
- C. During summer day camp, your immediate supervisor is the camp director. Overall supervision will be from the Special Recreation Coordinator.
- D. The Inclusion Support Team will monitor your performance and provide feedback, if necessary, on steps for improving inclusion.
- E. You will be jointly evaluated by the Inclusion Support Team and the Village of Orland Park Supervisors and staff.

This verbiage is very useful for both inclusion staff as well as year round special recreation staff. There can be 2 versions created one to focus on 1:1 inclusion classes and one for general programming with the Special Recreation Division. Also general verbiage from this section should be placed in the general Recreation Department Employee handbook. That way all areas have similar verbiage about Special Recreation Supports.

Village of Orland Park Recreation and Parks Department

Athlete and Parent Code of Conduct

As the Orland Park Special Olympic program continues to grow, it's necessary to introduce a code of conduct for everyone involved. All athletes and parents must abide by this code for all sports in which they are involved.

The primary purpose of this code of conduct is to ensure the safety and well-being of all athletes and coaches involved in our Special Olympics programs.

Please understand that everyone involved in our sporting events must abide by these rules. Any athlete, parent, and/or spectator not following the rules will be asked to remedy the situation for continued participation, or requested to withdraw from the remainder of the event. In cases of extreme repeated behavior, an athlete or parent will be suspended for a specific period of time or removed from Special Olympics indefinitely.

***Please read through the rules and sign the form at the bottom.**

1. Remain positive on the sidelines at all times. Yelling and/or coaching from the sidelines will not be allowed.
2. Spectators will remain in the bleachers or observation areas.
3. Respect the coaches' and official's decisions, regardless of whether or not you agree with them.
4. If you have a question regarding any decision please address the Head Coach. If you feel that the answer was not satisfactory please call the Recreation Specialist.
5. Respect all players on both teams. Rude comments toward teams, athletes, coaches or officials will not be tolerated.
6. Profanity or abusive language will not be tolerated.
7. Athlete Commitment to attending all tournaments.
8. Refrain from using any alcohol, illegal drugs, and any other controlled substances.
9. Special Olympics Illinois and The Village of Orland Park has a no tolerance policy in regard to physical altercations involving coaches, athletes, unified partners, volunteers, spectators, family member, etc.
10. Refrain from using drugs for the purpose of improving my performance.
11. Refrain from dating or having a relationship with any Special Olympics volunteer or staff member.
12. Respect all Village of Orland Park facilities and equipment.
13. Refrain from violent or disruptive behavior

14. An understanding of the rules may lead to a more positive experience at events. All Special Olympics Illinois sports follow the designated National Governing Body (NGB) rules and any exceptions or modifications to those rules are included in the Special Olympics Illinois Rules Interpretations for the sport. A list of the designated NGB rules and the Rules Interpretations can be found at www.soill.org in the coach section.
15. Keep in mind the Special Olympics oath and remember that winning is not the emphasis of Special Olympics competition.
16. Coaches should be the ones to do the coaching. Please refrain from shouting instructions to athletes.
17. ALL CHEERS should be positive and display good sportsmanship. Derogatory comments directed to players, coaches, and officials will not be tolerated.

Name: _____

Date: _____

Phone: _____

Circle One: Athlete Parent

By signing this document, you agree to adhere to the above codes of conduct and agree to the steps taken in case a code is broken.



Village of Orland Park Recreation Department

Coaches Code of Conduct

The primary purpose of this code of conduct is to ensure the safety and well-being of all athletes and coaches involved in our Special Olympics programs. All coaches must abide by this code for all sports in which they are involved.

Please understand that everyone involved in our sporting events must abide by these rules. Any coach not following the rules will be asked to remedy the situation for continued participation, or be requested to leave the event. In cases of extreme repeated behavior, a coach will be suspended for a specific period of time or removed from Special Olympics indefinitely.

All Special Olympics coaches must agree to the following codes:

- I will respect the rights, dignity and worth of athletes, coaches, other volunteers, friends and spectators in Special Olympics.
- I will treat everyone equally regardless of sex, ethnic origin, religion or ability.
- I will be a positive role model for the athletes I coach.
- I will ensure that for each athlete I coach, the time spent with Special Olympics is positive.
- I will respect the talent, developmental stage and goals of each athlete.
- I will ensure each athlete competes in events that challenge that athlete's potential and are appropriate to that athlete's ability.
- I will be fair, considerate and honest with athletes and communicate with athletes using simple, clear language.
- I will ensure that accurate scores are provided for entry of an athlete into any event.
- I will instruct each athlete to perform to the best of the athlete's ability at all preliminaries/heats and finals in accordance with Special Olympics Sports Rules.
- My language, manner, punctuality, preparation and presentation will demonstrate high standards.
- I will display control, respect, dignity and professionalism to all involved in the sport (athletes, coaches, opponents, officials, administrators, parents, spectators, media, etc).
- I will encourage athletes to demonstrate the same qualities.
- I will not drink alcohol, smoke or take illegal drugs while representing Special Olympics at training sessions or during competition.
- I will refrain from any form of personal abuse towards athletes and others, including verbal, physical and emotional abuse. Special Olympics Illinois has a no tolerance policy in regard to physical altercations involving coaches, athletes, unified partners, volunteers, spectators, family members, etc.
- I will be alert to any form of abuse from other sources directed toward athletes in

- my care.
- I will not date or have a sexual relationship with any Special Olympics athlete. Please refer to the Volunteer/Athlete Dating Policy for complete details regarding this policy.
- I will seek continual improvement through performance evaluation and ongoing coach education.
- I will be knowledgeable about the Sports Rules and skills of the sport(s) I coach.
- I will provide a planned training program.
- I will keep copies of the medical, training, and competition records for each athlete I coach.
- I will follow the Special Olympics and the National Governing Body rules for my sport(s).
- I will ensure that the equipment and facilities are safe to use.
- I will ensure that the equipment, rules, training and the environment are appropriate for the age and ability of the athletes.
- I will review each athlete's medical form and be aware of any limitations noted on that athlete's participation form.
- I will encourage athletes to seek medical advice when required.
- I will maintain the same interest and support towards sick and injured athletes.
- I will allow further participation in training and competition only when appropriate

Coaches Signature:

Date: _____

Phone: _____

By signing this document, you agree to adhere to the above codes of conduct and agree to the steps taken in case a code is broken.



Village of Orland Park Recreation Department

Coaches Code of Conduct

The primary purpose of this code of conduct is to ensure the safety and well-being of all athletes and coaches involved in our Special Olympics programs. All coaches must abide by this code for all sports in which they are involved.

Please understand that everyone involved in our sporting events must abide by these rules. Any coach not following the rules will be asked to remedy the situation for continued participation, or be requested to leave the event. In cases of extreme repeated behavior, a coach will be suspended for a specific period of time or removed from Special Olympics indefinitely.

All Special Olympics coaches must agree to the following codes:

- I will respect the rights, dignity and worth of athletes, coaches, other volunteers, friends and spectators in Special Olympics.
- I will treat everyone equally regardless of sex, ethnic origin, religion or ability.
- I will be a positive role model for the athletes I coach.
- I will ensure that for each athlete I coach, the time spent with Special Olympics is positive.
- I will respect the talent, developmental stage and goals of each athlete.
- I will ensure each athlete competes in events that challenge that athlete's potential and are appropriate to that athlete's ability.
- I will be fair, considerate and honest with athletes and communicate with athletes using simple, clear language.
- I will ensure that accurate scores are provided for entry of an athlete into any event.
- I will instruct each athlete to perform to the best of the athlete's ability at all preliminaries/heats and finals in accordance with Special Olympics Sports Rules.
- My language, manner, punctuality, preparation and presentation will demonstrate high standards.
- I will display control, respect, dignity and professionalism to all involved in the sport (athletes, coaches, opponents, officials, administrators, parents, spectators, media, etc).
- I will encourage athletes to demonstrate the same qualities.
- I will not drink alcohol, smoke or take illegal drugs while representing Special Olympics at training sessions or during competition.
- I will refrain from any form of personal abuse towards athletes and others, including verbal, physical and emotional abuse. Special Olympics Illinois has a no tolerance policy in regard to physical altercations involving coaches, athletes, unified partners, volunteers, spectators, family members, etc.
- I will be alert to any form of abuse from other sources directed toward athletes in

- my care.
- I will not date or have a sexual relationship with any Special Olympics athlete. Please refer to the Volunteer/Athlete Dating Policy for complete details regarding this policy.
- I will seek continual improvement through performance evaluation and ongoing coach education.
- I will be knowledgeable about the Sports Rules and skills of the sport(s) I coach.
- I will provide a planned training program.
- I will keep copies of the medical, training, and competition records for each athlete I coach.
- I will follow the Special Olympics and the National Governing Body rules for my sport(s).
- I will ensure that the equipment and facilities are safe to use.
- I will ensure that the equipment, rules, training and the environment are appropriate for the age and ability of the athletes.
- I will review each athlete's medical form and be aware of any limitations noted on that athlete's participation form.
- I will encourage athletes to seek medical advice when required.
- I will maintain the same interest and support towards sick and injured athletes.
- I will allow further participation in training and competition only when appropriate

Coaches Signature:

Date: _____

Phone: _____

By signing this document, you agree to adhere to the above codes of conduct and agree to the steps taken in case a code is broken.

Toolkit



for the assessment of Bus Stop Accessibility and Safety





Table of Contents

Introduction	1
Contact Information.....	2
Project Advisory Committee and Team	3
Members of the Committee:	3
Myths of Bus Stop Accessibility	5
Principles of Bus Stop Design.....	7
Barrier-Free Design	7
Urban Wayfinding	7
Safety and Warning	8
How to Conduct a Bus Stop Inventory	9
Sample Bus Stop Checklist	10
Creating Accessible and Safe Bus Stops.....	13
Distinction Between ADA Requirements and Universal Design	13
Design Guidelines.....	14
Bus Stop Area and Bus Landing Pads	14
Bus Shelter Design	19
Lighting.....	23
Security.....	24
Accessible Path	25
Route and Timetable Information.....	29
Transit Signage.....	30
Amenities.....	33
Identifying a Bus Stop by People with Visual Impairments.....	38
Maintenance of Bus Stops and Shelters	39
Key Players and Agency Coordination.....	41
Interdepartmental Collaboration.....	42
Driver Training and Support	43
Reducing Bus Operator Tasks.....	43
Cooperation Between Drivers and Bus Stop Planners	44

Technology and Product Links	45
Talking Signs® Technology	45
Automated Docking Systems.....	45
NextBus	47
i-Stops.....	49
Bus Stop Shelter Product Links	49
Urban and Rural Bus Stops.....	51
Population with Disabilities in Urban and Rural Areas	51
Rural Bus Stops.....	52
Appendix A. Quick Bus Stop Checklist.....	A-1
Appendix B. Tri-Met Maintenance Guidelines.....	B-1
Appendix C. Case Studies/Examples of Agency Coordination	C-1
Appendix D. Sample Agreement for Private Road Bus Stop Placement	D-1
Appendix E. Field Test Locations	E-1
Appendix F. Useful Resources.....	F-1

Table of Figures

Figure 1. Acceptable Color Combinations Based on Contrast	54
Figure 2. NextBus Information Flow.....	69
Figure 3. Bus Information Display	70
Figure 4. Disability Demographics in Urban and Rural America.....	74

INTRODUCTION

Bus stops are a key link in the journey of a bus rider. For people with disabilities, inaccessible bus stops often represent the weak link in the system and can effectively prevent the use of fixed-route bus service. Physical, cognitive, and psychological barriers associated with bus stops can severely hamper bus ridership by the disability community, thus limiting their mobility and potentially leading to increased paratransit costs.

This toolkit is primarily targeted towards staff at transit agencies and public works departments who are responsible for bus stop design and placement. The toolkit is intended to be a convenient resource that can be used to enhance the accessibility of specific bus stops, or help in the development of a strategic plan to achieve system-wide accessibility. Disability community representatives should also find in these pages material that can be used to advocate for accessibility improvements and barrier removal.

We encourage you to selectively draw on the sections that are most relevant to your situation. Your feedback on the toolkit will be most appreciated, and can be submitted either via a telephone call to Easter Seals Project ACTION, or via a short survey. Please let us know if there are critical topics that should be included in future versions of the toolkit.



Use the Toolkit to:

- Determine minimum ADA requirements
- Enhance bus stop accessibility through universal design
- Inventory bus stops
- Develop a strategic plan for system-wide accessibility
- Advocate for improvements



CONTACT INFORMATION

The Toolkit for Bus Stop Accessibility and Safety Assessment is provided by Easter Seals Project ACTION (Accessible Community Transportation In Our Nation). Funded through a cooperative agreement with the U.S. Department of Transportation, Federal Transit Administration, Project ACTION promotes cooperation between the transportation industry and the disability community to increase mobility for people with disabilities under the ADA and beyond.

For information, questions or assistance, please contact:

Easter Seals Project ACTION

Address: 700 13th Street NW, Suite 200, Washington, DC 20005

Phone: 202.347.3066 or 800.659.6428

Fax: 202.737.7914

TDD: 202.347.7385

Email: projectaction@easterseals.com

Web Address: www.projectaction.org

PROJECT ADVISORY COMMITTEE AND TEAM

The Toolkit was developed by Nelson\Nygaard Consulting Associates with the aid of the Project ACTION Advisory Committee and Team. Committee and Team members represented the diverse interests of transit agencies, people with disabilities, and various local, state and federal agencies.

Members of the Committee:

- Billy Altom, Delta Resource Center for Independent Living, Project ACTION National Steering Committee, Pine Bluff, Arkansas
- Alexandra Enders, Center on Disability in Rural Communities, University of Montana, Missoula, Montana
- Dennis Cannon, U.S. Access Board, Washington, DC
- Julie Kirschbaum, San Francisco County Transportation Authority, San Francisco, California
- Kevin Irvine, Equip for Equality, Inc., Chicago, Illinois
- Marilyn Golden, Disability Rights Education and Defense Fund, Berkeley, California
- Robert Del Rosario, AC Transit, Oakland, California
- Tim Renfro, Pierce Transit, Lakewood, Washington

Nelson\Nygaard was assisted by significant contributions from the following team members:

- Access Compliance Services, Santa Cruz, California
- Center of Inclusive Design and Environmental Access, School of Architecture and Planning, University at Buffalo, Buffalo, New York
- June Kailes, Disability Policy Consultant, Playa Del Rey, California
- Robert Perrone Consulting, Palm Springs, California
- Smith-Kettlewell Eye Research Institute, San Francisco, California



MYTHS OF BUS STOP ACCESSIBILITY

Myth 1: Only a small percentage of the transit ridership will benefit from bus stop accessibility improvements.

- Accessibility improvements for people with disabilities enhance the usability of transit systems for all riders. For example, paving a grassy surface to serve as a bus stop landing pad provides a stable surface for waiting patrons; adequate lighting alleviates the security issues of using the bus after dark; and good information reduces ambiguity of the system. Accessibility improvements should be viewed within the context of general system usability, not as “those things you do for those other people.”
- Accessibility improvements also benefit people with a range of disabilities, from physical conditions affecting mobility, stamina, sight, hearing and speech to other conditions, such as emotional illness and learning disorders. Such disabilities may or may not be evident to others. The percentage of the U.S. population affected by a condition that constitutes a disability under the Americans with Disabilities Act (ADA) is expected to increase over the coming decades, in part due to the growing elderly population. Additionally, transit users carrying packages or luggage, pushing children in strollers, or otherwise transporting items will also benefit from accessibility improvements.¹

Myth 2: Bus stop accessibility and safety improvements are not our responsibility.

- As bus stops are located on the public right-of-way or on private property, transit agencies may not have jurisdiction to implement improvements. Though this may be the case, it is in the interest of the transit agency to work with its municipality, community and businesses on bus stop improvements. Bus stops advertise an image of the transit service and agency. Poorly maintained, unsafe, uninformative and inaccessible stops convey a poor image of the agency and discourage use.
- Rising paratransit costs are another reason bus stop safety and accessibility improvements should be the responsibility of the transit agency. Providing an unobstructed landing pad, wayfinding signs, clear transit information at the eye level of a wheelchair user and other basic improvements can encourage some paratransit users to use fixed route transit, decreasing the agency's paratransit costs.
- Lastly, several transit agencies have been sued and lost cases due to the inaccessibility of their bus stops. Transit agencies are required to provide accessible transit, and accessible bus stops are an integral part of an accessible system. Similarly, public works departments are required to construct accessible facilities and ensure program accessibility of existing facilities.



¹ Public Rights-of-Way Access Advisory Committee, *Building a True Community* U.S. Access Board 2001.



Myth 3: Once we have implemented bus stop accessibility improvements, the stop will always be accessible.

- Though accessibility and safety improvements have been implemented, the stop may not meet standards indefinitely. Many factors may decrease accessibility and safety, including construction, unregulated placement of newspaper vending machines and poor maintenance. Stops should be regularly monitored to ensure that the stop is clear of obstructions.

Myth 4: To change flag stops to fixed bus stops, each new stop must have a landing pad.

- New bus stops should be accessible to all patrons. Agencies are not required, however, to install landing pads at all stops. Where landing pads are provided, they must comply with the requirements stated in the section on Bus Stop Area and Bus Landing Pads. It is recommended that fixed bus stops be located where there is a stable, level, raised and slip-resistant surface to facilitate boarding and alighting for all passengers. If this type of surface is not available at the location chosen for the bus stop, a landing pad should be installed. If patrons who use wheelchairs are not able to use the stop, the transit agency would fail to meet the overarching mandate of Title II of the ADA to provide accessible transportation.

Myth 5: We can prohibit patrons with wheelchairs from boarding and alighting at stops that are not currently accessible.

- A transit agency may not legally prohibit the boarding and alighting of passengers with wheelchairs, unless the lift or ramp would be damaged if deployed, or if temporary conditions at the stop prevent any disembarkation. If the bus stop is located in an area where conditions would damage the lift, such as a steep slope, it is recommended that the driver stop at a nearby location that has a stable surface.²

² ADA DOT Regulation Sec. 37.167(g): Other service requirements, http://www.fta.dot.gov/legal/regulations/us_dot/5601_5606_ENG_HTML.htm

PRINCIPLES OF BUS STOP DESIGN³

For a bus stop to be accessible, three elements should be incorporated into the siting and design of the stop. These elements are:

1. Barrier-Free Design
2. Urban Wayfinding
3. Safety and Warning

Barrier-Free Design

Barrier-Free Design entails designing a bus stop and path so that a person with a disability can proceed unimpeded to the sidewalk or an accessible building served by the transit stop. The basic principles of Barrier-Free Design include:

- Planning outdoor elements to minimize obstacles and eliminate travel hazards such as support cables for utility poles and low signage protruding into the travel path.
- Positioning newspaper boxes and other street furniture close to the edge of a travel path, out of the main flow of pedestrian traffic and the bus landing pad.
- Avoiding grade-level changes in sidewalk and platforms wherever possible.
- Providing slip-resistant finishes, good grip and sure footing to ensure surfaces are safe.
- Supplying seating adjacent to pathway routes.

Urban Wayfinding

Wayfinding is the process of movement from one predetermined destination to another, and is an activity that demands complete involvement with the environment. The basic principles of orientation and wayfinding are:

- Providing consistency and uniformity of elements and layout
- Simplifying orientation by using right angles for design elements and layout



The use of paving stones creates a park-like feel and makes this bus stop in Palm Springs, California tactually and visually distinct from the adjacent concrete sidewalk.

Source: Robert Perrone Consulting

³ Province of Alberta, Transportation & Utilities, *Design Guidelines for Accessible Pedestrian Environments* 1996.



- Providing tactile as well as visual cues and landmarks within designs (examples: sidewalks with grass shoulders or borders; street furnishings such as benches; garbage receptacles; planters located adjacent to but not within path of travel; high contrasts on shelter door frames)
- Illuminating walkways, hazards and waiting areas for orientation and security purposes
- Providing logical, unbroken travel paths from sidewalk to bus boarding platform
- Using color contrast, sound, light and shade to accentuate travel paths between shelter, sidewalk and bus boarding platform

Safety and Warning

As with all aspects of roadway design and bus operations, an important element in the design of bus stops is safety and warning.

The basic principles of safety and warning are:

- Providing a bus stop with good ergonomics and effective wayfinding will also be beneficial for safety and warning purposes
- Placing street furniture such as benches, newspaper vending boxes, and planters to create barriers from hazards
- Ensuring good lighting and visibility from surrounding land uses
- Highlighting the existence of hazards by distinctive markings, signs and higher light levels where inadvertent exposure to hazards cannot be blocked

HOW TO CONDUCT A BUS STOP INVENTORY

Inventorying conditions at and around bus stops is the first step in determining and implementing improvements. The data can also be used to communicate the bus stop location, coordinates, surrounding land uses and its condition for patrons with disabilities to inform them of the stop's travel path and accessibility. Additionally, a database of existing conditions provides the opportunity to comply with ADA regulations, coordinate with other agencies and consider real time information.

For information on how to conduct and maintain a bus stop inventory, refer to *Bus Stop Inventory: Best Practices and Recommended Procedures*, from the Bus Stop Inventory Task Force of the Transit Standards Consortium, Incorporated. The Transit Standards Consortium is comprised of transit industry stakeholders and conducts research, testing, training and maintenance of transit standards to improve transit's quality of service. The Bus Stop Inventory manual is a useful resource in developing and utilizing a valuable inventory.

The manual can be purchased from the website, <http://www.tsconsortium.org>. The table of contents of the report is reproduced below.



Chapter	Content
1	Introduction
2	Planning a Bus Stop Inventory
3	Components of a Bus Stop Inventory
4	Field Collection
5	Integration and Maintenance
6	Summary and Conclusion
Appendix One	Acronyms, Definitions
Appendix Two	Core Elements, Associated Elements, Related Subsystem Elements
Appendix Three	Design and Development of a Bus Stop Inventory to Support an Intelligent Transportation System: The MARTA Experience
Appendix Four	Creating a Bus Stop Inventory and Transit Scheduling Database for Metro
Appendix Five	Dallas Bus Stop Database Design
Appendix Six	Statement of Work Sample
Appendix Seven	Case Studies



Transit agency official measures the distance between the edge of the shelter and the curb, using a measuring wheel, to determine if enough clearance is available for wheelchair users to board and alight the bus.

Source: Nelson\Nygaard Consulting Associates

Sample Bus Stop Checklist

The Sample Bus Stop Checklist is based on a model utilized by Arlington County in Virginia, and modified to incorporate items and ideas from other checklists and feedback from a series of field tests.⁴ Toolkit users are encouraged to customize the checklist according to the needs of their transit services, by changing lines directly in the tool. The Sample Bus Stop Checklist is intended for use by transit and public works agencies. A Quick Bus Stop Checklist is available for advocates and the general public.

Though the checklist may be completed at any time of day, certain sections, such as the Lighting Assessment, are best performed in the evening or night-time to effectively determine the safety, security and accessibility of the stop.

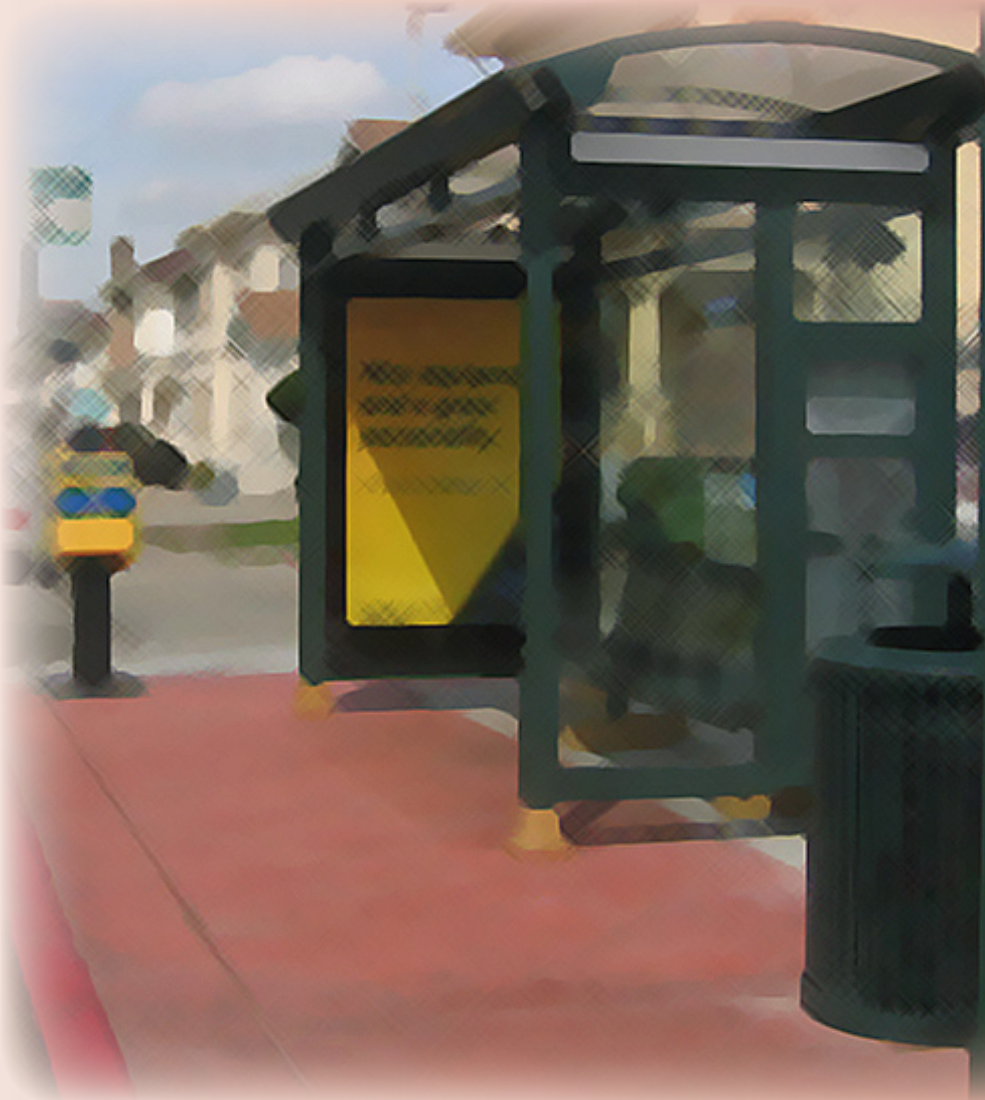
The equipment needed to acquire data for the site is listed below, divided into “basic” and “additional.” These categories are based on the type of information the transit agency is collecting, the use of paper forms or computer and the level of accuracy desired.

- **Basic:**
 - ✘ Database
 - ✘ Checklist
 - ✘ Clipboard
 - ✘ Camera (preferably digital to be able to download to a database)
 - ✘ Measuring wheel
- **Additional**
 - ✘ Handheld device or laptop onto which the checklist can be downloaded
 - ✘ Global Positioning System (GPS) to calculate the location of the bus stop
 - ✘ Vehicle with GPS outfitted with computer equipment and sensors to transport the crew to the bus stop locations and gather data

⁴ Refer to Appendix E for a list of locations where the Checklist was tested.

After conducting the bus stop inventory:

- If the checklist was completed using paper forms, the information gathered should be entered into a database. An Excel spreadsheet or Access database are the most convenient ways to store the information.
- Once a database is created, the data may be used to prioritize improvements according to the condition of the stop or shelter, the use of the stop by persons with disabilities, ridership, and/or the importance of the connections provided by the bus stop location. The database should be updated to include the current conditions at the stop.



BUS STOP CHECKLIST

PART A: IDENTIFICATION/LOCATION

<i>Route Name:</i>	<i>Location:</i>	<i>Weather Conditions:</i>	<i>Stop No.:</i>
--------------------	------------------	----------------------------	------------------

PART A: IDENTIFICATION/LOCATION		Yes	No	N/A
A1	Is there a bus shelter?	<input type="checkbox"/>	<input type="checkbox"/>	<input type="checkbox"/>
	<i>If YES, what is the number of the shelter?</i>			
	<i>If NO, is there an exterior alternative shelter nearby (i.e. - awning, overhangs, underpass)?</i>	<input type="checkbox"/>	<input type="checkbox"/>	<input type="checkbox"/>
A2	Street Name:			
A3	Nearest Cross Street (street name or landmark if mid-block):			
A4	Bus Route Direction:			
	North Bound <input type="checkbox"/>	South Bound <input type="checkbox"/>	More than one direction <input type="checkbox"/>	
	East Bound <input type="checkbox"/>	West Bound <input type="checkbox"/>		
A5	What is the purpose of the stop?			
	Park and Ride <input type="checkbox"/>	Boarding <input type="checkbox"/>	Both Boarding and Alighting <input type="checkbox"/>	Other (specify): <input type="checkbox"/>
	Kiss and Ride <input type="checkbox"/>	Alighting <input type="checkbox"/>	Transfer <input type="checkbox"/>	
A6	What is the average number of daily boardings at the stop?			
A7	Where is the bus stop positioned in relation to the nearest intersection?			
	Nearside (Before the bus crosses the intersection)	<input type="checkbox"/>		
	Far Side (After the bus crosses the intersection)	<input type="checkbox"/>		
	Mid-block	<input type="checkbox"/>		
	Not near an intersection	<input type="checkbox"/>		
	Freeway bus pad	<input type="checkbox"/>		
	N/A	<input type="checkbox"/>		

<i>Date</i>	<i>Time:</i>	<i>Surveyor:</i>
-------------	--------------	------------------

BUS STOP CHECKLIST

PART A: IDENTIFICATION/LOCATION

<i>Route Name:</i>	<i>Location:</i>	<i>Weather Conditions:</i>	<i>Stop No.:</i>
--------------------	------------------	----------------------------	------------------

A8	Distance from bus stop pole to curb of cross street in feet:			
A9	Adjacent property address or name of business (only if readily visible):			
A10	Adjacent Property Description:			
	Apartment Building <input type="checkbox"/>	Industrial Site/Bldg. <input type="checkbox"/>	Park <input type="checkbox"/>	School <input type="checkbox"/>
	Day Care <input type="checkbox"/>	Library <input type="checkbox"/>	Park and Ride <input type="checkbox"/>	Supermarket <input type="checkbox"/>
	Government Building <input type="checkbox"/>	Mall/Shopping Center <input type="checkbox"/>	Place of Worship <input type="checkbox"/>	Transit station/center <input type="checkbox"/>
	Hospital <input type="checkbox"/>	Nursing Home <input type="checkbox"/>	Residence – townhouse <input type="checkbox"/>	Vacant lot <input type="checkbox"/>
	Human Service Agency <input type="checkbox"/>	Office Building <input type="checkbox"/>	Residence – detached <input type="checkbox"/>	Other (specify): <input type="checkbox"/>
		Retail Store <input type="checkbox"/>		
A11	Distance from previous bus stop (in feet):			

<i>Date</i>	<i>Time:</i>	<i>Surveyor:</i>
-------------	--------------	------------------

BUS STOP CHECKLIST

PART B: PEDESTRIAN ACCESS FEATURES

<i>Route Name:</i>	<i>Location:</i>	<i>Weather Conditions:</i>	<i>Stop No.:</i>
--------------------	------------------	----------------------------	------------------

PART B: PEDESTRIAN ACCESS FEATURES

Section B-1: Landing Area Assessment

B1	Is there a landing area at least 5 feet wide and 8 feet deep adjacent to the curb/street?			Yes <input type="checkbox"/>	No <input type="checkbox"/>	
B2	Where is the landing area positioned in relation to the curb/street?					
	Below street level (low ground or shoulder) <input type="checkbox"/>	Shoulder <input type="checkbox"/>	Other (specify): <input type="checkbox"/>			
	Sidewalk <input type="checkbox"/>	Adjacent <input type="checkbox"/>	Bus Bulb <input type="checkbox"/>	Off-Road/No sidewalk <input type="checkbox"/>		
B3	What is the material of the landing area?					
	Asphalt <input type="checkbox"/>	Dirt <input type="checkbox"/>	Gravel <input type="checkbox"/>	Other (specify): <input type="checkbox"/>		
	Concrete <input type="checkbox"/>	Grass <input type="checkbox"/>	Pavers <input type="checkbox"/>			
B4	Are there problems with the landing area surface?				Yes <input type="checkbox"/>	No <input type="checkbox"/>
	<i>If YES, rank resulting accessibility potential:</i>					
		Not Accessible	Minimally Accessible	Accessible		
	Uneven	<input type="checkbox"/>	<input type="checkbox"/>	<input type="checkbox"/>		
	Slopes up from the street	<input type="checkbox"/>	<input type="checkbox"/>	<input type="checkbox"/>		
	Slopes down from the street	<input type="checkbox"/>	<input type="checkbox"/>	<input type="checkbox"/>		
	Requires stepping over drain inlet	<input type="checkbox"/>	<input type="checkbox"/>	<input type="checkbox"/>		
Other (Specify)	<input type="checkbox"/>	<input type="checkbox"/>	<input type="checkbox"/>			
B5	Are there any obstacles that would limit the mobility of a wheelchair?				Yes <input type="checkbox"/>	No <input type="checkbox"/>
	<i>If YES, describe obstruction:</i>					

<i>Date</i>	<i>Time:</i>	<i>Surveyor:</i>
-------------	--------------	------------------

BUS STOP CHECKLIST

PART B: PEDESTRIAN ACCESS FEATURES

<i>Route Name:</i>	<i>Location:</i>	<i>Weather Conditions:</i>	<i>Stop No.:</i>
--------------------	------------------	----------------------------	------------------

B6	Additional landing area comments:		
B7	Landing area recommendations:		
	Widen sidewalk to expand landing area to 5 feet wide and 8 feet deep		<input type="checkbox"/>
	Install curb bulb or remove on street parking		<input type="checkbox"/>
	Move object to improve accessibility (specify where):		
	Make the following repairs (specify):		
Other (specify):			

Section B-2: Connections (Trip Generators)

B8	What are the primary trip generators for passengers at this stop? (Check all that apply)		
	Apartments - large building/complex <input type="checkbox"/>	Human service agency – what kind? <input type="checkbox"/>	School –Elementary/Middle <input type="checkbox"/>
	Apartments - small building <input type="checkbox"/>	Library <input type="checkbox"/>	School -High <input type="checkbox"/>
	Townhomes <input type="checkbox"/>	<u>Major Shopping/employment</u> (Mall, Wal-Mart, Kmart, Target, other big department store) <input type="checkbox"/>	School - College/University/ Technical school <input type="checkbox"/>
	Detached homes <input type="checkbox"/>	<u>Neighborhood Shopping</u> (supermarket, drugstore, Goodwill, strip mall with basic needs shopping) <input type="checkbox"/>	Senior center <input type="checkbox"/>
	Day care/pre-school <input type="checkbox"/>	Nursing home/assisted living <input type="checkbox"/>	Transfer to other bus routes <input type="checkbox"/>
	Gas station <input type="checkbox"/>	Office building/employment <input type="checkbox"/>	Transit station/center <input type="checkbox"/>
	Government building <input type="checkbox"/>	Park and Ride lot <input type="checkbox"/>	Other (Specify): <input type="checkbox"/>
	Hospital/major clinic <input type="checkbox"/>	Place of worship <input type="checkbox"/>	
	Hotel <input type="checkbox"/>	Restaurant <input type="checkbox"/>	

<i>Date</i>	<i>Time:</i>	<i>Surveyor:</i>
-------------	--------------	------------------

BUS STOP CHECKLIST

PART B: PEDESTRIAN ACCESS FEATURES

<i>Route Name:</i>	<i>Location:</i>	<i>Weather Conditions:</i>	<i>Stop No.:</i>
--------------------	------------------	----------------------------	------------------

B9	How wide is the sidewalk?			
	No sidewalk <input type="checkbox"/>	less than 3' <input type="checkbox"/>	3'-5' <input type="checkbox"/>	5' or greater <input type="checkbox"/>
B10	Are there physical barriers that constrict the width of the sidewalk within the block on which the bus stop is located?			Yes <input type="checkbox"/> No <input type="checkbox"/>
	<i>If YES, what is the narrowest useable width:</i>			
	Less than 3' <input type="checkbox"/>		3' or greater <input type="checkbox"/>	
B11	Rank the condition of the sidewalk:			
	1 <input type="checkbox"/>	2 <input type="checkbox"/>	3 <input type="checkbox"/>	4 <input type="checkbox"/>
	5 <input type="checkbox"/>			
	<i>1=hazardous – large breaks, cracks, root uplifting, someone could get hurt from normal use or use of a wheelchair would be difficult</i>			
	<i>2=in poor shape though not hazardous – very rough, some root uplifting, cracks, breaks</i>			
<i>3=fair – minor root uplifting, minor cracks or breaks</i>				
<i>4=good – not perfect but no immediate repair</i>				
<i>5=cosmetically excellent; new</i>				
B12	Does the landing pad connect to the sidewalk?			Yes <input type="checkbox"/> No <input type="checkbox"/>
	<i>If YES, what does the sidewalk connect to:</i>			
	One of the trip generators listed in Question B8 <input type="checkbox"/>		The nearest intersection <input type="checkbox"/>	
B13	Where is the nearest street crossing opportunity?			
	The nearest intersection <input type="checkbox"/>		Mid-block crosswalk <input type="checkbox"/>	
B14	What pedestrian amenities are at the nearest intersection (or other crossing opportunity)?			
	Curb cuts all corners/ both sides <input type="checkbox"/>	Pedestrian crossing signal <input type="checkbox"/>	Traffic Light <input type="checkbox"/>	
	Visible crosswalk <input type="checkbox"/>	Audible crosswalk signal <input type="checkbox"/>	Crossing guard assistance <input type="checkbox"/>	
	Curb cuts at some corners/one side <input type="checkbox"/>	Accessible Pedestrian Signal (APS) <input type="checkbox"/>	Tactile warning strip on curb cut <input type="checkbox"/>	
			Other (specify): <input type="checkbox"/>	

<i>Date</i>	<i>Time:</i>	<i>Surveyor:</i>
-------------	--------------	------------------

BUS STOP CHECKLIST

PART B: PEDESTRIAN ACCESS FEATURES

<i>Route Name:</i>	<i>Location:</i>	<i>Weather Conditions:</i>	<i>Stop No.:</i>
--------------------	------------------	----------------------------	------------------

B15	Is there a companion bus stop across the street?	Yes No N/A <input type="checkbox"/> <input type="checkbox"/> <input type="checkbox"/>
B16	Are there connections to other transportation services at this bus stop?	Yes No <input type="checkbox"/> <input type="checkbox"/>
	<i>If YES, check all that apply</i>	
	Bus services, same or other agency <input type="checkbox"/>	Local Rail <input type="checkbox"/>
Greyhound <input type="checkbox"/>		Other (Specify): <input type="checkbox"/>
B17	Pedestrian connection recommendations:	
	Construct sidewalk	<input type="checkbox"/>
	Widen sidewalk	<input type="checkbox"/>
	Improve landing area connections to sidewalk	<input type="checkbox"/>
	Install curb cut(s) at:	
	Move object to improve accessibility (specify where):	
	Make the following repairs (specify):	
Other (specify):		
B18	Additional pedestrian connection comments:	

<i>Date</i>	<i>Time:</i>	<i>Surveyor:</i>
-------------	--------------	------------------

BUS STOP CHECKLIST

PART C: PASSENGER COMFORT AMENITIES

<i>Route Name:</i>	<i>Location:</i>	<i>Weather Conditions:</i>	<i>Stop No.:</i>
--------------------	------------------	----------------------------	------------------

PART C: PEDESTRIAN COMFORT AMENITIES

Section C-1: Shelters (move to Section C-2 if there is no shelter)

C1	What is the orientation of the bus shelter in relation to the street?										
	Facing towards the street					<input type="checkbox"/>					
	Facing on-coming traffic					<input type="checkbox"/>					
	Facing away from the street					<input type="checkbox"/>					
C2	What kind of shelter is it? Insert shelter relevant to your system.										
	Own transit agency	<input type="checkbox"/>	Another transit agency (shared stop)	<input type="checkbox"/>	Other (Specify): <input type="checkbox"/>						
C3	If non-standard shelter, what are the approximate dimensions (width, height and depth in feet) of the interior standing area?										
	Width:										
	Height:										
	Depth:										
C4	Does the shelter have a front center panel (i.e. two openings)?					Yes No <input type="checkbox"/> <input type="checkbox"/>					
	<i>If YES, what are the dimensions of the opening?</i>										
C5	Could a person using a wheelchair maneuver into the shelter?					Yes No <input type="checkbox"/> <input type="checkbox"/>					
C6	Could a person using a wheelchair fit completely under the shelter (minimum space of a common mobility device is 30 in. by 48 in. (760 mm by 1200mm))?					Yes No <input type="checkbox"/> <input type="checkbox"/>					
	What are the dimensions of the clear space in the shelter?										
C7	What is the distance of the front of the shelter from the curb in feet?										
	0 - 2'	<input type="checkbox"/>	2' - 4'	<input type="checkbox"/>	4' - 6'	<input type="checkbox"/>	6' - 8'	<input type="checkbox"/>	8' - 10'	<input type="checkbox"/>	>10'

<i>Date</i>	<i>Time:</i>	<i>Surveyor:</i>
-------------	--------------	------------------

BUS STOP CHECKLIST

PART C: PASSENGER COMFORT AMENITIES

<i>Route Name:</i>	<i>Location:</i>	<i>Weather Conditions:</i>	<i>Stop No.:</i>
--------------------	------------------	----------------------------	------------------

C8	Are there damages to the bus shelter?	Yes <input type="checkbox"/>	No <input type="checkbox"/>	
	<i>If YES, check all that apply:</i>			
	Broken panels	<input type="checkbox"/>		
	Graffiti	<input type="checkbox"/>		
	Holes in the roof	<input type="checkbox"/>		
	Missing panels	<input type="checkbox"/>		
	Needs repainting	<input type="checkbox"/>		
Other (specify):	<input type="checkbox"/>			
C9	What is the approximate age of the shelter?			
C10	Rank the condition of the shelter:			
	1 <input type="checkbox"/>	2 <input type="checkbox"/>	3 <input type="checkbox"/>	4 <input type="checkbox"/>
<i>1=hazardous – broken glass, unstable 2=in poor shape though not hazardous 3=fair – needs repainting, glass panels need thorough cleaning, protruding but not hazardous bolts 4=good – not perfect but no immediate repair need 5=cosmetically excellent; new</i>				
C11	Additional shelter comments:			

<i>Date</i>	<i>Time:</i>	<i>Surveyor:</i>
-------------	--------------	------------------

BUS STOP CHECKLIST

PART C: PASSENGER COMFORT AMENITIES

<i>Route Name:</i>	<i>Location:</i>	<i>Weather Conditions:</i>	<i>Stop No.:</i>
--------------------	------------------	----------------------------	------------------

C12	Shelter recommendations:	
	Remove center panel	<input type="checkbox"/>
	Make the following repairs (specify):	<input type="checkbox"/>
	Move object to improve accessibility (specify where):	
	Move shelter to improve accessibility (specify where):	
	Other (specify):	

Section C-2: Seating Assessment (move to Section C-3 if there is no seating)

C13	What is the type of seating available?	
	Bench inside shelter – skip to question C15	<input type="checkbox"/>
	Freestanding bench	<input type="checkbox"/>
	Fold down bench	<input type="checkbox"/>
	Leaning bench	<input type="checkbox"/>
	Other (specify):	<input type="checkbox"/>

C14	If not inside shelter, what is the distance of the seating from the curb in feet?						
	0 - 2' <input type="checkbox"/>	2' - 4' <input type="checkbox"/>	4' - 6' <input type="checkbox"/>	6' - 8' <input type="checkbox"/>	8' - 10' <input type="checkbox"/>	>10' <input type="checkbox"/>	

C15	Are there problems with the seating?	Yes <input type="checkbox"/> No <input type="checkbox"/>
	<i>If YES, check all that apply:</i>	
	Broken pieces	<input type="checkbox"/>
	Needs painting	<input type="checkbox"/>
	Graffiti	<input type="checkbox"/>
	Not securely installed	<input type="checkbox"/>
	Other (specify):	<input type="checkbox"/>

<i>Date</i>	<i>Time:</i>	<i>Surveyor:</i>
-------------	--------------	------------------

BUS STOP CHECKLIST

PART C: PASSENGER COMFORT AMENITIES

<i>Route Name:</i>	<i>Location:</i>	<i>Weather Conditions:</i>	<i>Stop No.:</i>
--------------------	------------------	----------------------------	------------------

C16	Rank the condition of the seating:									
	<table border="1"> <tr> <td>1</td> <td><input type="checkbox"/></td> <td>2</td> <td><input type="checkbox"/></td> <td>3</td> <td><input type="checkbox"/></td> <td>4</td> <td><input type="checkbox"/></td> <td>5</td> <td><input type="checkbox"/></td> </tr> </table> <p> <i>1=hazardous – broken, someone could get hurt from normal use</i> <i>2=in poor shape though not hazardous</i> <i>3=fair – needs repainting, needs cosmetic attention,, protruding but not hazardous bolts</i> <i>4=good – not perfect but no immediate repair need</i> <i>5=cosmetically excellent; new</i> </p>	1	<input type="checkbox"/>	2	<input type="checkbox"/>	3	<input type="checkbox"/>	4	<input type="checkbox"/>	5
1	<input type="checkbox"/>	2	<input type="checkbox"/>	3	<input type="checkbox"/>	4	<input type="checkbox"/>	5	<input type="checkbox"/>	
C17	Additional seating comments:									
C18	Seating recommendations:									
	Move seating to improve accessibility (specify where):									
	Make the following repairs (specify):									
	Other (specify):									

<i>Date</i>	<i>Time:</i>	<i>Surveyor:</i>
-------------	--------------	------------------

BUS STOP CHECKLIST

PART C: PASSENGER COMFORT AMENITIES

<i>Route Name:</i>	<i>Location:</i>	<i>Weather Conditions:</i>	<i>Stop No.:</i>
--------------------	------------------	----------------------------	------------------

Section C-3: Trash Assessment (move to Section C-4 if there is no trash receptacle)	
C19	What is the type of installation for the trash receptacle?
	Attached to the shelter <input type="checkbox"/>
	Free standing <input type="checkbox"/>
	Garbage bag <input type="checkbox"/>
	Bolted to sidewalk <input type="checkbox"/>
Other (specify): <input type="checkbox"/>	
C20	Are there problems with the trash receptacle and surrounding area? Yes No
	<input type="checkbox"/> <input type="checkbox"/>
	<i>If YES, check all that apply:</i>
	Trash can very full <input type="checkbox"/>
	Graffiti at bus stop <input type="checkbox"/>
	Bus stop littered <input type="checkbox"/>
	Grocery carts left at stop <input type="checkbox"/>
	Trash can not securely installed <input type="checkbox"/>
Adjacent property littered <input type="checkbox"/>	
Other (specify): <input type="checkbox"/>	
C21	Additional Comments:
C22	Trash recommendations:
	Install trash can due to litter problem <input type="checkbox"/>
	Make the following repairs (specify):
	Move trash can to improve accessibility (specify where):
Other (specify):	

<i>Date</i>	<i>Time:</i>	<i>Surveyor:</i>
-------------	--------------	------------------

BUS STOP CHECKLIST

PART C: PASSENGER COMFORT AMENITIES

<i>Route Name:</i>	<i>Location:</i>	<i>Weather Conditions:</i>	<i>Stop No.:</i>
--------------------	------------------	----------------------------	------------------

Section C-4: Newspaper Boxes (move to Part D if there are no newspaper boxes)		
C23	Are the newspaper boxes a barrier to sidewalk use?	Yes No <input type="checkbox"/> <input type="checkbox"/>
C24	Are the newspaper boxes a barrier to bus access/egress?	Yes No <input type="checkbox"/> <input type="checkbox"/>
C25	Are they chained to the bus stop pole, shelter, or bench?	Yes No <input type="checkbox"/> <input type="checkbox"/>
C26	Are they blocking access to posted bus schedule info?	Yes No <input type="checkbox"/> <input type="checkbox"/>
C27	Additional newspaper box comments:	
C28	Newspaper box recommendations:	
	Move trash can to improve accessibility (specify where):	
	Other (specify):	

<i>Date</i>	<i>Time:</i>	<i>Surveyor:</i>
-------------	--------------	------------------

BUS STOP CHECKLIST

PART D: SAFETY AND SECURITY FEATURES

<i>Route Name:</i>	<i>Location:</i>	<i>Weather Conditions:</i>	<i>Stop No.:</i>
--------------------	------------------	----------------------------	------------------

PART D: Safety and Security Features		
Section D-1: Traffic and Pedestrian Issues		
D1	Where is the bus stop area located?	
	In travel lane	<input type="checkbox"/>
	Bus lane/pull off area	<input type="checkbox"/>
	Paved shoulder	<input type="checkbox"/>
	In right turn only lane	<input type="checkbox"/>
	Unpaved shoulder	<input type="checkbox"/>
	Off street	<input type="checkbox"/>
	“No Parking” portion of street parking lane	<input type="checkbox"/>
Other (specify):	<input type="checkbox"/>	
D2	Is the bus stop zone designated as a no parking zone?	Yes No <input type="checkbox"/> <input type="checkbox"/>
	<i>If YES, indicated by:</i>	
	One “No Parking” sign	<input type="checkbox"/>
	2 or more “No Parking” signs	<input type="checkbox"/>
	“Bus Only” sign	<input type="checkbox"/>
	Painted curb	<input type="checkbox"/>
	Painted street	<input type="checkbox"/>
D3	Are cars parked between the landing area and the bus stopping area?	Yes No <input type="checkbox"/> <input type="checkbox"/>
D4	What is the posted speed limit in MPH?	Not posted <input type="checkbox"/>
D5	What are the traffic controls at the nearest intersection for the street?	
	Traffic signals	<input type="checkbox"/>
	Flashing lights	<input type="checkbox"/>
	Stop/Yield sign	<input type="checkbox"/>
	None	<input type="checkbox"/>
Other (specify):	<input type="checkbox"/>	

<i>Date</i>	<i>Time:</i>	<i>Surveyor:</i>
-------------	--------------	------------------

BUS STOP CHECKLIST

PART D: SAFETY AND SECURITY FEATURES

<i>Route Name:</i>	<i>Location:</i>	<i>Weather Conditions:</i>	<i>Stop No.:</i>
--------------------	------------------	----------------------------	------------------

D6	How many total lanes are on both sides of the road?	1 <input type="checkbox"/>	2 <input type="checkbox"/>	3 <input type="checkbox"/>	4 <input type="checkbox"/>	Other (specify): <input type="checkbox"/>	N/A <input type="checkbox"/>	
		Yes No N/A <input type="checkbox"/> <input type="checkbox"/> <input type="checkbox"/>						
D7	Is there on-street parking permitted just before or after the bus stop zone?							
	<i>If YES, what is the length of the "No Parking" area in feet:</i>							
D8	Are there potential traffic hazards?						Yes No <input type="checkbox"/> <input type="checkbox"/>	
	<i>Yes, check all that apply:</i>							
	The bus stop is just over the crest of a hill						<input type="checkbox"/>	
	The bus stop is just after a curve in the road						<input type="checkbox"/>	
	The bus stop is near an at-grade railroad crossing						<input type="checkbox"/>	
	Waiting passengers are hidden from view of approaching bus						<input type="checkbox"/>	
	A stopped bus straddles the crosswalk						<input type="checkbox"/>	
	Bus stop just before crosswalk						<input type="checkbox"/>	
	High speed traffic						<input type="checkbox"/>	
	No crosswalk						<input type="checkbox"/>	
	Other (specify)						<input type="checkbox"/>	
D9	Additional traffic safety comments / recommendations:							
Section D-2: Lighting Assessment (assessment preferably taken in the evening or at night) Go to Section D-3 if no lighting								
D10	What type of lighting is available?							
	Street light						<input type="checkbox"/>	
	Shelter lighting						<input type="checkbox"/>	
	Outside light on adjacent building						<input type="checkbox"/>	
	Other (specify):						<input type="checkbox"/>	

<i>Date</i>	<i>Time:</i>	<i>Surveyor:</i>
-------------	--------------	------------------

BUS STOP CHECKLIST

PART D: SAFETY AND SECURITY FEATURES

<i>Route Name:</i>	<i>Location:</i>	<i>Weather Conditions:</i>	<i>Stop No.:</i>
--------------------	------------------	----------------------------	------------------

D11	Does the light produce a glare?	Yes No <input type="checkbox"/> <input type="checkbox"/>
D12	How even is the light distributed?	Yes No <input type="checkbox"/> <input type="checkbox"/>
D13	Additional comments:	

Section D-3: Pay Phone

D14	Is there a pay phone within the immediate vicinity? <i>If NO, skip to Question D16.</i>	Yes No <input type="checkbox"/> <input type="checkbox"/>
D15	Is the pay phone within reach of a wheelchair user?	Yes No <input type="checkbox"/> <input type="checkbox"/>
D16	If no pay phone is provided, is there a police call box?	Yes No <input type="checkbox"/> <input type="checkbox"/>
D17	Additional comments:	

Section D-4: Landscaping Assessment

D18	Are there problems with the landscaping around the bus stop? <i>If YES, check all that apply:</i>	Yes No <input type="checkbox"/> <input type="checkbox"/>
	Trees/bushes encroaching on the landing area	<input type="checkbox"/>
	Trees/bushes encroaching on the sidewalk	<input type="checkbox"/>
	Tree branches that would hit the bus	<input type="checkbox"/>
	Other (specify):	<input type="checkbox"/>

<i>Date</i>	<i>Time:</i>	<i>Surveyor:</i>
-------------	--------------	------------------

BUS STOP CHECKLIST**PART D: SAFETY AND SECURITY FEATURES**

<i>Route Name:</i>	<i>Location:</i>	<i>Weather Conditions:</i>	<i>Stop No.:</i>
--------------------	------------------	----------------------------	------------------

D19	Additional comments:
------------	----------------------

Section D-5: Safety Recommendations

D20	Improve pedestrian safety by:	<input type="checkbox"/>
	Trim trees or branches	<input type="checkbox"/>
	Move bus stop to:	
	Other (specify):	

<i>Date</i>	<i>Time:</i>	<i>Surveyor:</i>
-------------	--------------	------------------

BUS STOP CHECKLIST

PART E: INFORMATION FEATURES

<i>Route Name:</i>	<i>Location:</i>	<i>Weather Conditions:</i>	<i>Stop No.:</i>
--------------------	------------------	----------------------------	------------------

PART E: Information Features		
E1	Is there a bus stop sign?	Yes No <input type="checkbox"/> <input type="checkbox"/>
	<i>If NO, move to question E6.</i>	
E2	What provider name is on the bus stop (<i>list all providers utilizing stop</i>)?	
	Provider 1:	
	Provider 2:	
	Provider 3:	
	Provider 4:	
E3	Are bus routes indicated on the bus stop sign?	Yes No <input type="checkbox"/> <input type="checkbox"/>
	<i>If YES, what routes?</i>	
E4	How is the sign installed?	
	On its own pole	<input type="checkbox"/>
	On a building	<input type="checkbox"/>
	On a utility pole	<input type="checkbox"/>
	On a shelter	<input type="checkbox"/>
	Other (specify):	<input type="checkbox"/>
E5	Are there problems with the signage?	Yes No <input type="checkbox"/> <input type="checkbox"/>
	<i>If YES, check all that apply:</i>	
	Sign in poor condition	<input type="checkbox"/>
	Pole in poor condition	<input type="checkbox"/>
	Sign position hazardous to pedestrians	<input type="checkbox"/>
	Sign not permanently mounted	<input type="checkbox"/>
	Lighting on sign is poor	<input type="checkbox"/>
	Other (specify):	<input type="checkbox"/>

<i>Date</i>	<i>Time:</i>	<i>Surveyor:</i>
-------------	--------------	------------------

BUS STOP CHECKLIST

PART E: INFORMATION FEATURES

<i>Route Name:</i>	<i>Location:</i>	<i>Weather Conditions:</i>	<i>Stop No.:</i>
--------------------	------------------	----------------------------	------------------

E6	Is there route/schedule/map (circle as appropriate) information posted?	Yes No <input type="checkbox"/> <input type="checkbox"/>
	<i>If NO please move to question E9.</i>	
E7	Where is the route/schedule/map (circle as appropriate) information posted?	
	On Pole under bus stop sign	<input type="checkbox"/>
	On its own pole	<input type="checkbox"/>
	On a building	<input type="checkbox"/>
	On a utility pole	<input type="checkbox"/>
	On a shelter	<input type="checkbox"/>
	In a shelter	<input type="checkbox"/>
	Other (specify):	<input type="checkbox"/>
E8	Is the information at eye level of a wheelchair user?	Yes No <input type="checkbox"/> <input type="checkbox"/>
E9	Is there a schedule rack?	Yes No <input type="checkbox"/> <input type="checkbox"/>
	<i>If YES, are repairs needed?</i>	Yes No <input type="checkbox"/> <input type="checkbox"/>
E10	Is there real time information display?	Yes No <input type="checkbox"/> <input type="checkbox"/>
	<i>If YES, is it at eye level of a wheelchair user?</i>	Yes No <input type="checkbox"/> <input type="checkbox"/>
E11	Is signage text ADA compliant (refer to the <i>Toolkit for the Assessment of Bus Stop Accessibility and Safety</i> for guidelines)?	Yes No <input type="checkbox"/> <input type="checkbox"/>
E12	Is information provided in Braille or by a Talking Signs® transmitter for people with visual impairments?	Yes No <input type="checkbox"/> <input type="checkbox"/>
E13	Additional signage & information comments:	
E14	Signage & information recommendations:	
	Make the following repairs:	<input type="checkbox"/>
	Other (specify):	<input type="checkbox"/>

<i>Date</i>	<i>Time:</i>	<i>Surveyor:</i>
-------------	--------------	------------------

BUS STOP CHECKLIST

PART F: DIAGRAMMATIC SKETCH OR PHOTOGRAPH

<i>Route Name:</i>	<i>Location:</i>	<i>Weather Conditions:</i>	<i>Stop No.:</i>
--------------------	------------------	----------------------------	------------------

PART F: Diagrammatic Sketch or Photograph

Sketch or photograph the layout of the bus stop area and any traffic controls. On sketch or photograph, be sure to note locations of:

Bus stop sign pole	Newspaper boxes	Traffic signals/stop signs
Other poles	Anything else installed at bus stop	Railroad tracks
Landing Pad	Sidewalks	Bus stop across the street
Shelter	Sidewalk barriers	Heating units in shelters
Bench	Crosswalks	Bike racks
Trash can	Curb cuts	North/South/East/West

<i>Date</i>	<i>Time:</i>	<i>Surveyor:</i>
-------------	--------------	------------------



CREATING ACCESSIBLE AND SAFE BUS STOPS

Distinction Between ADA Requirements and Universal Design⁵

Accessible design focuses on compliance with laws and regulations and state or local building codes. The laws and regulations are intended to eliminate certain physical barriers that limit the usability of environments for people with disabilities. These typically were based on the requirements detailed by the American National Standards Institute. With the passage of the Americans with Disabilities Act (ADA) in 1990 and the subsequent development of the ADA Accessibility Guidelines, accessible design has focused more recently on satisfying these minimum technical criteria to allow most people with disabilities to use the built environment. The ADA Standards are the minimum requirements that comply with the law. They are not necessarily “best practices.”

Universal design is intended to create environments that are usable by all people. While considerations for people with disabilities are certainly necessary for universal design, they are not sufficient when planning and designing for the whole population. Universal design provides a higher level of access for people with disabilities. It also accommodates the needs and wishes of everyone - e.g., children, older adults, women and men. Parents pushing strollers, travelers pulling luggage, the older man needing a little more time to cross a street - all benefit from features of universal design. For additional background information on universal design, visit the Global Universal Design Educator’s Network, <http://www.ueducation.org/>.



The ADA Standards are the minimum requirements that comply with the law. They are not “best practices.” Universal design is intended to create environments that are more usable by all people, including people with disabilities.

⁵ City of New York Office of the Mayor, *Universal Design New York*. Center for Inclusive Design and Environmental Access, School of Architecture and Planning, University at Buffalo, Buffalo, New York 2001.



This bus stop in New York City has a bus landing area that is free of obstructions for both front and rear doors. The sidewalk adjacent to the bus stop platform is wide enough to handle high pedestrian activity and for a wheelchair user to pass without entering the bus stop area.

Source: Metropolitan Transportation Authority

Design Guidelines

The following sections list accessibility benefits, minimum ADA requirements and universal design recommendations for the various elements of a bus stop.

Bus Stop Area and Bus Landing Pads

A bus stop platform is a designated bus stop area clear of obstructions to facilitate boarding and alighting for all users.

Accessibility Benefits

Providing a designated bus stop area benefits all transit users. An area the length of the bus for transit purposes provides a comfortable waiting, alighting and boarding area for both front and rear doors and denotes the transit agency's presence. Wheelchair users will have less difficulty boarding and alighting the bus when there is a stable, level and unobstructed landing pad to operate the wheelchair lift and ramp. Wheelchair and scooter users require more space to wait and turn around than other transit users and therefore benefit from sufficient area at the bus stop to maneuver.⁶

Minimum ADA Requirements

Providing accessible bus stops requires choosing appropriate locations or improving the existing location. Coordination and cooperation with public works agencies, municipal government and business owners can enhance the connectivity between the land use and the bus stop. To ensure optimum bus stop placement, coordination should occur during the planning/development phase.

Bus stop sites must have the following:⁷

- A firm, stable surface;
- A minimum clear length of 96 inches (2,440 millimeters), measured from the curb or vehicle roadway edge and a minimum clear width of 60 inches (1,524 millimeters), measured parallel to the vehicle roadway;

⁶ McMillen, Barbara et al. *Designing Sidewalks and Trails for Access: Part I of II: Review of Existing Guidelines and Practices*. 1999.

⁷ ADA Accessibility Guidelines for Buildings and Facilities (ADAAG), Section 10.

- A maximum slope of 1:50 (2%) for water drainage; and
- Connection to streets, sidewalks or pedestrian paths by an accessible route.

Universal Design

Finding the proper location for a bus stop is challenging. Community Transit in Everett, Washington enlists help from the agency’s bus drivers to determine where best to situate a stop. To test the potential locations, temporary markers, such as orange cones with bus stop signs, are installed and maintained while the local public is solicited for input.⁸

The bus stop platform guidelines outlined in this section are not required but are strongly recommended to facilitate accessibility and safety for all users.

- **Bus Stop Area⁹**
 - ✧ Locate street furniture to maintain a minimum clear width of 48 inches (1,219 millimeters) and clear headroom of 80 inches (2,032 millimeters) from the pedestrian pathway to the stop
 - ✧ Clear the bus stop platform of all obstacles (including trees, newspaper boxes, waste and recycling receptacles)
 - ✧ Design the sidewalk adjacent to the bus stop platform to be wide enough to handle the expected levels of pedestrian activity and for two wheelchair users to pass each other traveling in opposite directions when two-way traffic is frequent
- **Bus Stop Area - Door Clearances¹⁰**
 - ✧ The front and rear door areas of a bus stop should be kept clear of trees, utility poles, wires, hydrants and other infrastructure or street furniture. Because different types and sizes of buses are used, all bus stop platforms should account for the variance in door positions.

- **Types of Bus Stop Areas**

Various configurations of bus stop areas are available to accommodate passenger waiting, boarding and alighting. Determining the type of platform to use depends on traffic conditions, bus priority, space availability and the number of users at the stop.

⁸ Nelson\Nygaard, Interview with Tony Smith, Community Transit, March 31, 2005.

⁹ Transit Cooperative Research Program (TCRP) Report 19 *Guidelines for the Location and Design of Bus Stops* 1996.

¹⁰Province of Alberta, Transportation & Utilities, 1996.



The parked car leaves little clearance for the bus to pull in flush to the curb.

Picture taken in Oakland, California.
Source: NelsonNygaard Consulting Associates



This bus bay in Tucson, Arizona prohibits parking and denotes a wheelchair accessible area.

Source: NelsonNygaard Consulting Associates

- **Curbside stop**

Curbside stops are typically installed on existing sidewalks. In urban areas, the stop is located in the parking lane. The length of the stop's curb may be painted a distinctive color to prevent or discourage parking. In suburban areas, the curbside stop may be located in the travel lane as the street may not incorporate a parking lane.

Advantages of Curbside Stops
<ul style="list-style-type: none"> • Provides access to bus stops • Simple in design and inexpensive for transit agency to install
Disadvantages of Curbside Stops
<ul style="list-style-type: none"> • May present problems for drivers trying to pull in flush to the stop's curb if not enough entering clearance is given due to parked cars (as shown in the picture to the left) • May present problems for bus drivers trying to reenter traffic, especially during periods of high volume traffic

- **Bus Bay¹¹**

Bus bays provide an area for buses to leave the main road to pick up passengers. They often have a shelter and other amenities for the waiting passenger.

Advantages of Bus Bays
<ul style="list-style-type: none"> • Allows passengers to board and alight out of the travel lane • Provides a protected area away from traffic for both the stopped bus and patrons • Minimizes delay to through traffic
Disadvantages of Bus Bays
<ul style="list-style-type: none"> • May present problems for bus drivers trying to reenter traffic, especially during periods of high volume traffic • Is expensive to install compared to curbside stops • Is difficult and expensive to relocate

¹¹ Transit Cooperative Research Program (TCRP) Report 19, 1996.

- **Bus Bulb**

Advantages of Bus Bulbs
<ul style="list-style-type: none"> • Allows drivers to pull in flush to the curb • Results in minimal delay to the bus
<ul style="list-style-type: none"> • Allows for more waiting room for bus patron separated from the pedestrian flow and space for amenities
Disadvantages of Bus Bulbs
<ul style="list-style-type: none"> • Can cause traffic to queue up behind the bus, causing traffic delay • Expensive to install compared to curbside stops • Difficult and expensive to relocate

- **Amenities**

The bus stop platform can benefit from various amenities and treatments. These are discussed in the Amenities Section.



A bus bulb in San Francisco, California. The bus stop area is extended into the parking lane and incorporates a shelter that does not impede the pedestrian right of way. The bulb allows the bus driver to pull up flush to the curb to facilitate the boarding and alighting of passengers.

Source: NelsonNygaard Consulting Associates



Examples of Bus Stop Areas and Landing Pads

The pictures on this page give examples of bus stops with good and poor accessibility.



The lack of a stable and firm landing pad and accessible path makes this stop in British Columbia inaccessible. Rider safety is compromised as the poor drainage and grassy/muddy waiting area create slippery conditions.

Source: BC Transit



This stop in Berkeley, California does not have adequate clearance to deploy a wheelchair ramp. Additionally, the stop lacks identity, being indiscernible from a newspaper vending machine area.

Source: NelsonWygaard Consulting Associates



The stop area and landing pad are clear of obstructions in Oakland, California. There is enough room for wheelchair users to maneuver, and the stop is spatially and visually distinct from the pedestrian walkway.

Source: NelsonWygaard Consulting Associates

Bus Shelter Design

A bus shelter provides protection from the elements and seating while waiting for a bus. Standardized shelters exist that accommodate various site demands and passenger volumes. Typically, a shelter is constructed of clear side-panels for visibility and safety.

Accessibility and Safety Benefits

The seating and protection provided by shelters benefits bus patrons with mobility impairments. Additionally, a shelter clearly marks a bus stop, supplies an area to post route and timetable information and provides refuge for waiting passengers, separated from the public way. Shelters located in areas with good lighting and visibility from surrounding land uses enhance the safety of the stop.

Minimum ADA Requirements¹²

Install new or replace bus shelters to accommodate the following:

- A minimum clear floor area of 30 inches by 48 inches (762 millimeters by 1,219 millimeters), entirely within the perimeter of the shelter; and
- Connected by an accessible route to the bus stop landing pad.

Additionally,

- Bus stop shelters should not be placed on the wheelchair landing pad
- General ADA mobility clearance guidelines should be followed around the shelter and between the shelter and other street furniture
- A clearance of 36 inches (914 millimeters) should be maintained around the shelter and an adjacent sidewalk (more is preferred)



¹² ADA Accessibility Guidelines for Buildings and Facilities (ADAAG), Section 10.



The bus shelter is placed on a concrete block that is level with the sidewalk. It provides a stable surface for wheelchair users and does not impose on the bus landing pad area. *Photo taken in Mableton, Georgia.*

Source: G. Araki www.the-bus-stops-here.org

Universal Design¹³

When to Install a Shelter

The decision to install a shelter is the result of system-wide policy among transit agencies. In most instances, the estimated number of passenger boardings is the most important determinant. Suggested boarding levels by area type used to decide when to install a shelter are as follows (these values represent a composite of prevailing practices):

Location	Minimum Boardings
Rural	10 boardings per day
Suburban	25 boardings per day
Urban	50 to 100 boardings per day

Location

Ideally, the location of a bus stop shelter should enhance the circulation patterns of patrons, reduce the amount of pedestrian congestion at a bus stop, and reduce conflict with nearby pedestrian activities. The following guidelines should be used when placing a bus stop shelter at a stop:

- Permit clear passage of the bus and its side mirror with a minimum distance of 24 inches (610 millimeters) between the back-face of the curb and the roof or panels of the shelter. Greater distances are preferred to separate waiting passengers from nearby vehicular traffic
- Locate the shelter as close as possible to the end of the bus stop zone and provide visibility to approaching buses and passing traffic
- Preserve a 12-inch (305 millimeter) clear space to permit trash removal and cleaning of the shelter when shelters are directly adjacent to a building

Design Considerations

Shelter design is based on criteria related to climate, agency, policies and streetscape context. The following are general design guidelines that assist in providing accessibility and safety:

- Incorporate shelter dimensions that are 9 feet long and 5 feet wide (2.7 meters by 1.5 meters)

¹³ Transit Cooperative Research Program (TCRP) Report 19, 1996.

- Design shelters with transparent sides for visibility and security¹⁴
- Mark glass panels with distinctive pattern such as horizontal contrasting strips or circles, to indicate the presence of the panels
- Include transit route maps, schedules, and seating in shelters. Maps and schedules should be easily readable by persons using wheelchairs and, to the greatest extent possible, persons with visual impairments
- Provide seating, if feasible, with sufficient space to move around
- Provide surfaces to lean against if seating is not provided
- Omit steps between the sidewalk/bus pad and the shelter
- Maintain shelter openings to be a minimum of 36 inches (914 millimeters) clear to allow a wheelchair to pass through
- Consider heated shelters at high ridership stops in cold climates.

Seating

Seats provide comfort to waiting customers and increase the attractiveness of the bus service, especially for those with mobility impairments. Patrons who have difficulty standing will benefit from seating and will more likely use transit services. Seating located in the shelter should leave clear space for patrons with wheelchairs to use the shelter.

Environmental Controls

In orienting and configuring bus shelters, personnel should consider the environmental characteristics of each site. Shelters can be completely open to permit unlimited movement of air in hot climates, or panels can be erected to keep the interior of the bus shelter warm. The following examples provide guidance on the type and placement of shelters for various climates:

- **Cold Climates**

In areas where winter temperatures are low, installing shelters with wind protection and investing in heated shelters for large bus stops and transfer points may provide incentive for customers to use the transit service.



This shelter in Rochester, New York, provides two openings for entering and exiting, as well as wind protection from the northern climate.

Source: Rochester Genesee Regional Transportation



These two shelters in Toronto, Canada, open onto the sidewalk to provide protection from snow or water splashed by moving cars. The shelter is enclosed except for the entranceway to protect against inclement weather.

Source: SUNY Buffalo

¹⁴ Province of Alberta, Transportation & Utilities, 1996.



This shelter located in Palm Springs, California allows air to circulate. The panels are constructed of perforated metal to allow airflow while maintaining good visibility of the surrounding area.

Source: Robert Perrone Consulting



Shelter with advertising placed downstream of traffic flow and good visibility in Oakland, California.

Source: Nelson/Nygaard Consulting Associates

- **Hot Climates**

In southern climates with mild winter temperatures and extreme summer temperatures, shelters can be designed to be completely open to air circulation from all four sides. At sites with wind, rain, or glare problems, standardized shelters can be retrofitted with panels to provide protection and shade. In the Southwestern region of the United States, air temperatures can reach above 110 degrees Fahrenheit on a regular basis during the summer. Transit agencies can induce people to ride the bus in these conditions by providing cool air misters and evaporation cooling towers.

Location of Advertising

Many transit agencies have paid advertising in bus shelters to reduce costs and to provide other benefits. Passenger and pedestrian safety and security are of greater concern at shelters with advertising. The advertising panels may limit views in and around a bus stop, making it difficult for bus drivers to see patrons. The panels can also reduce incidental surveillance from passing traffic. To prevent restricted sight lines, advertising panels should be placed downstream of the traffic flow, to assist an approaching bus driver view the interior of the shelter easily. Indirect surveillance from passing traffic should be preserved through proper placement of the panels.¹⁵

¹⁵ Transit Cooperative Research Program (TCRP) Report 19, 1996.

Lighting

Lighting affects bus patrons' perception of safety and security at a bus stop, as well as the use of the site by non-bus patrons. Good lighting can enhance a waiting passenger's sense of comfort and security; poor lighting may encourage unintended use of the facility by non-bus patrons, especially after hours. Lighting is particularly important in northern climates where patrons may arrive and return to the stop in darkness during the winter season.¹⁶

Accessibility Benefits

Bus patrons who have low visibility in dimly lighted areas benefit from good lighting at and around the bus stop. As stated before, lighting benefits all users by increasing the safety and security of the stop.

Minimum ADA Requirements

No specific ADA lighting requirements.

Universal Design

The following are highly recommended to provide a safe waiting environment:

- Installing lighting that provides between 2 to 5 footcandles.¹⁷ A footcandle is a unit of illuminance on a surface that is a uniform point source of light of one candela and equal to one lumen per square foot.¹⁸
- Illuminating bus patron's faces. Multiple sources of light are more resistant to vandalism and provide illumination that casts fewer intimidating shadows. Lighting that is too bright in bus shelters can also compromise personal safety, creating a fish bowl effect whereby the transit user can easily be seen by others but cannot see outside.¹⁹

¹⁶ Transit Cooperative Research Program (TCRP) Report 19, 1996.

¹⁷ Transit Cooperative Research Program (TCRP) Report 19, 1996.

¹⁸ Merriam-Webster Online, <http://www.m-w.com/cgi-bin/dictionary?va=foot-candles>

¹⁹ Vogel, Mary and Pettinari, James L., *Personal Safety and Transit: Paths, Environments, Stops, and Stations* Center for Transportation Studies, University of Minnesota 2002.



Indirect lighting illuminates the shelter and sidewalk in New York City, New York. The shelter is constructed with glass panels on all four sides, providing good visibility and better security.

The shelter is designed with vandal proof, flexible PV cells with hidden batteries and energy efficient LEDs. Solar electricity is stored during the day to provide security at night. There is no connection to a grid or excavation costs to install electricity.

Source: SUNY Buffalo

- Ensuring light fixtures are vandal-proof but easily maintained. For example, avoid using exposed bulbs or elements that can be easily tampered with or destroyed.²⁰
- Locating bus stops near existing streetlights for indirect lighting. When coordinating bus shelter or bench locations with existing streetlights, the minimum clearance guidelines for the wheelchairs should be followed.²¹ Several transit agencies have installed shelters with solar panels so that light can be provided “free” even in remote areas.

Security²²

Passenger security is a major issue in bus stop design and location and can positively or negatively influence a bus patron’s perception of the bus stop. From the perspective of security, landscaping, walls, advertising panels, and solid structures can restrict sight lines and provide spaces to hide. Each of these items can be an integral part of the bus stop, either by design or by proximity of existing land uses. Therefore, the transit and public works agencies should carefully review which amenities are to be included at a bus stop and consider any factors that may influence security.

Accessibility Benefits

Security provisions enhance accessibility by increasing visibility of the stop. They reduce the safety concerns of waiting at the stop at all hours, improve visibility from the stop and also provide information that is useful for planning trips and maintaining personal safety.

Minimum ADA Requirements

No specific ADA security requirements.

²⁰ Transit Cooperative Research Program (TCRP) Report 19, 1996.

²¹ Ibid.

²² Ibid.

Universal Design

Some guidelines regarding security at bus stops are as follows:

- Constructing the bus shelter of materials that allow clear, unobstructed visibility of and to patrons waiting inside
- Locating bus stops at highly visible sites to permit approaching bus drivers and passing vehicular traffic to see the bus stop clearly. Proximity to stores and businesses also enhance surveillance of the site
- Limiting landscaping elements to low-growing shrubbery, ground cover and deciduous shade trees are preferred at bus stops. Evergreen trees provide a visual barrier and should be avoided
- Coordinating bus stops with existing street lighting to improve visibility.
- Maintaining the cleanliness of the bus stop. A well-maintained stop contributes to the concept of an owned environment. Refer to the Maintenance Section for more information
- Providing a Pay Phone or Police Call Box to allow emergency calls
- Providing accurate route and schedule information

Accessible Path

Walkways or sidewalks are essential links between the origin/destination of the trip and the bus stop. Their proper design and regular maintenance are important to providing a barrier-free travel path for all persons.

Accessibility Benefits

Accessible paths allow all users to reach their destination conveniently and safely. For users of mobility devices, an unobstructed, stable and wide pathway to the bus stop will facilitate use of the bus system. Wheelchair and scooter users require a wider path of travel than ambulatory pedestrians. Additionally, their stability and control can be affected by surfaces with cross-slopes, grades, or rough terrain. Cross-slopes that change very rapidly cause problems for wheelchair users. The rate of change of cross-slope is most problematic when it occurs over a distance of less than 24 feet (610 millimeters), the approximate distance covered by a wheelchair wheelbase.²³

²³ McMillen, Barbara et al. 1999.



People who use walking aids include those who use canes, crutches, or walkers to ease their ambulation. The limitations of walking-aid users might include the following:²⁴

- Difficulty negotiating steep grades
- Difficulty negotiating steep cross-slopes
- Decreased stability
- Slower walking speed
- Reduced endurance
- Inability to react quickly to dangerous situations
- Reduced floor reach

Minimum ADA Requirements²⁵

At minimum, an accessible path should accommodate the following:

- A minimum clear passage width of 48 inches (1,219 millimeters) is recommended by the Access Board’s guidelines for the public right-of-way. This is especially important next to a curb drop-off;
- An accessible route from public transportation stops to the route for the general public;
- A maximum cross slope of 1:50;
- Stable, firm and slip-resistant ground and floor surfaces; and
- Grating spaces that are no greater than 9 1/2 inches (13 millimeters) wide in one direction.

Objects may not protrude on an accessible route or maneuvering space. Guidelines for protruding objects are below:²⁶

- Objects projecting from walls (for example, telephones) with their leading edges between 27 inches and 80 inches (685 millimeters and 2,030 millimeters) above the finished floor shall protrude no more than 4 inches (100 millimeters) into pathway;
- Objects mounted with their leading edges at or below 27 inches (685 millimeters) above the finished floor may protrude any amount;

²⁴ McMillen, Barbara et al. 1999.

²⁵ ADA Accessibility Guidelines for Buildings and Facilities (ADAAG), Section 4.3.

²⁶ Ibid.

- Free-standing objects mounted on posts or pylons may overhang 12 inches (305 millimeters) maximum from 27 inches to 80 inches (685 millimeters to 2,030 millimeters) above the ground or finished floor;
- 80 inches (2,030 millimeters) minimum clear headroom. If vertical clearance of an area adjoining an accessible route is reduced to less than 80 inches (nominal dimension), provide a barrier to warn blind or visually-impaired persons.

Universal Design

- Sidewalks²⁷
 - ✎ Widen sidewalks to five or more feet to accommodate pedestrian activity in two directions and provide comfortable bus stop waiting area
 - ✎ Maintain walkways and bus stop areas to be clear of snow, ice and other debris
 - ✎ Provide an accessible travel path that is the shortest distance between the bus stop and the sidewalk or accessible building
 - ✎ Distinguish the surface of the bus stop from the surrounding areas to accommodate persons with visual impairments. The use of different textures, such as concrete, paving stone, contrasting colors, tactile strips and curbs help to delineate pathways
- Street Furniture and Other Obstacles in Travel Path
 - ✎ Locate street furniture and signage, such as benches, sign posts, newspaper boxes out of the travel path of pedestrians and transit passengers
 - ✎ Define pathway junction points and clear them of obstructions

- Curb Ramps

Grade-level changes are difficult for the elderly and persons with disabilities to negotiate. Any grade-level change without the aid of a curb ramp creates a mobility barrier. Refer to ADAAG Section 4.7 on Curb Ramps for more information.



Example of a curb ramp leading to a bus stop in Buffalo, New York.

Source: SUNY Buffalo

²⁷ Province of Alberta, Transportation & Utilities, 1996.



An accessible path is provided to and from the stop, linking the stop to the surrounding land uses in Eugene, Oregon.

Source: G. Araki www.the-bus-stops-here.org.



The lack of an accessible path makes it difficult for a wheelchair user to use this stop in Red Bluff, California. All users would have to travel on gravel and on the roadway shoulder to use the stop.

Source: G. Araki www.the-bus-stops-here.org.

Examples of Bus Stops with and without Accessible Paths

Ensuring that there is an unobstructed, stable and slip resistant path to the bus stop is essential to providing access to the bus for people with disabilities. The following examples show a stop that is well connected and others that are inconvenient for all bus patrons.



This bus stop in Buffalo, New York is not accessible, lacking a plowed path to the shelter. Bus patrons with and without disabilities will have difficulty getting to the stop and getting onboard the bus due to the thick layer of snow.

As it is difficult to clear snow from every bus stop, particularly those in residential neighborhoods, an agreement with property managers or residents may help with snow removal (refer to Adopt-a-Stop Program programs). In this case, an agreement between the transit agency and the property manager of the building adjacent to the stop can ensure that the bus stop and a path leading to the stop are cleared of snow when the parking lot is plowed.

Source: SUNY Buffalo

Route and Timetable Information²⁸

Route and passenger information can be displayed in various ways. A flag sign is the most common method used by transit agencies to display information. Schedule holders and route information on the shelters are also commonly used.

Accessibility Benefits

Reducing transit's ambiguity in terms of arrival time and route allows those with cognitive disabilities and general transit riders to use the system more effectively.

Minimum ADA Requirements

Follow ADA requirements on Accessible Path, Signage and Protruding Objects for access to information by individuals with disabilities (see sections on Accessible Path and Transit Signage).

Universal Design

Recommendations for route or patron information displays are as follows:

- Provide updated information when changes are made to routes and schedules
- Consider the quality and appearance of information displays. A visually poor route map conveys a negative impression of the system
- Make information displays permanent. Temporary methods for displaying information (such as taping) create a cluttered, unsophisticated appearance at the bus stop
- Shelters or stops should be designed to accommodate route and schedule information so it is not added in places that reduce visibility or security
- Use interior panels of shelters for posting route and schedule information. Side panels may be large enough to display the entire system map and can include backlighting for display at night
- Install real time information display boards at key stops to give patrons up to the minute information on bus arrival times and delays. For people with visual impairments, a button may be provided that gives audio information when pressed. A discussion of real time information is included in the Technology and Product Links section.



Example of good route information and placement in Loveland, Colorado. The information is not cluttered, and is provided in a prominent location, which reduces ambiguity in using the service.

Source: Access Compliance Services

	8th St @ Lincoln	Good Samaritan Village	28th East of Duffield
1	6:38	6:46	6:54
	7:38	7:46	7:54
	8:38	8:46	8:54
	9:38	9:46	9:54
	10:38	10:46	10:54

This picture provides a close-up of the timetable information provided in the above figure. The schedule is provided in large, easy to read text.

Source: Access Compliance Services

²⁸ Transit Cooperative Research Program (TCRP) Report 19, 1996.



The bus stop pole in Seattle, Washington displays the routes servicing the stop on a flag and timetables in an information panel. The information panel is at eye level of a wheelchair user.

Source: Sound Transit

Transit Signage

Proper signs at bus stops are an important element of good transit service. Signs serve as a source of information to patrons and operators regarding the location of the bus stop and are excellent marketing tools to promote transit use. Letter styles, sign appearance, and color choice should be unique to the transit system so that passengers can readily identify bus stops.

Accessibility Benefits

Transit signs are usually installed in an accessible position on the bus stop landing pad. For patrons using wheelchairs, the bus stop pole usually indicates where to access the wheelchair lift. To indicate the stop location for a patron who has visual impairments, the sign pole may be stylized to distinguish it from other poles on the path. For example, a perforated square pole uniquely identifies the stop. In Vancouver, British Columbia, a pole collar serves as a tactile marker.

Minimum ADA Requirements²⁹

Provide bus stop signage that accommodates the following:

- Letters and numbers to be a width-to-height ratio between 3:5 and 1:1 and a stroke-width-to-height ratio between 1:5 and 1:10;
- Characters and numbers sized according to the viewing distance from which they are to be read;
- Minimum height is measured using an upper case X. Lower case characters are permitted;
- Accompany pictograms with the equivalent verbal description placed directly below, with a border dimension of 6 inches (152 millimeters) minimum in height;
- Characters and background of signs in a non-glare finish, with characters and symbols contrasting from their background; and
- Follow protruding objects requirements (given in the section Accessible Path)

²⁹ ADA Accessibility Guidelines for Buildings and Facilities (ADAAG), Section 4.30.

Universal Design³⁰

Unlike other traffic signs, which conform to national engineering standards, transit signage is typically unique to each individual transit property. Customer information signs should be readily identifiable, legible, clear, and consistent not only for the general public but also for persons with disabilities. The following considerations for signs are recommended:

- Providing doublesided signs for visibility from both directions and reflectorized or illuminated signs for nighttime visibility
- Placing bus stop signs at the location where people board the front door of the bus. The bus stop sign marks the area where passengers should stand while waiting for the bus and serves as a guide for the bus operator in positioning the vehicle at the stop. The bottom of the sign should be at least 7 feet (2.1 meters) above ground level and should not be located closer than 2 feet (0.6 meters) from the curb face
- Deciding locations for bus stops and signposts should be coordinated with local and/or state jurisdictions.
- Ensuring that the signs are not obstructed by trees, buildings, or other signs and located away from visual distractions



Refer to Transit Cooperative Research Program (TCRP) Report 12, *Guidelines for Transit Facility Signing and Graphics* (http://gulliver.trb.org/publications/tcrp/tcrp_rpt_12-a.pdf) for detailed information on transit signage. One section of the report, highlighted in Figure 1 below, provides guidance on acceptable color combinations for signs based on contrast. Color contrast is of critical importance to persons with visual impairments. When selecting colors for information/guidance and directional signs, care should be taken to select colors that provide adequate contrast between the background and the characters, images, or pictographs.

³⁰ Transit Cooperative Research Program (TCRP) Report 19, 1996.



Figure 1. Acceptable Color Combinations Based on Contrast³¹

	Beige	White	Dark Grey	Black	Brown	Pink	Purple	Green	Orange	Blue	Yellow	Red
Red	Acceptable	Acceptable									Acceptable	
Yellow			Acceptable	Acceptable	Acceptable		Acceptable	Acceptable		Acceptable		
Blue	Acceptable	Acceptable										
Orange				Acceptable								
Green	Acceptable	Acceptable										
Purple	Acceptable	Acceptable										
Pink												
Brown	Acceptable	Acceptable										
Black	Acceptable	Acceptable										
Dark Grey		Acceptable										
White												
Beige												

 Acceptable (70% contrast or greater)
 Do not use

³¹ Transit Cooperative Research Program (TCRP) Report 12, *Guidelines for Transit Facility Signing and Graphics* 1996.

Amenities

Amenities benefit all transit patrons, if they do not reduce the minimum clear spaces required by ADAAG. This section outlines the optimal placement of various amenities.

Benches

Accessibility Benefits

Transit users who experience difficulty walking and standing benefit from benches while waiting for the bus. Benches are beneficial when a shelter with seating is not provided and if bus headways are longer than 15 minutes. At stops with high ridership, benches may be provided in addition to shelters to accommodate patrons.

Minimum ADA Requirements³²

If benches are provided, they should adhere to the following ADA regulations:

- Clear floor or ground space for wheelchairs (complying with ADAAG Section 4.2.4);
- Seat dimensions: 20 inches (510 millimeters) minimum to 24 inches (610 millimeters) maximum in depth and 42 inches (1,065 millimeters) minimum in length;
- Seat height: 17 inches (430 millimeters) minimum to 19 inches (485 millimeters) maximum above the floor or ground;
- Back support: 42 inches (1,065 mm) minimum in length and that extends from a point 2 inches (51 mm) maximum above the seat to a point 18 inches (455 mm) minimum above the seat;
- Structure supporting vertical or horizontal forces of 250 pounds. (1,112 Newtons) applied at any point on the seat, fastener, mounting device, or supporting structure; and
- Exposed benches: slip resistant and designed to shed water

Universal Design³³

The following recommendations coordinate bench placement with the bus stop environment to enhance safety and accessibility:

- Provide 17-inch (430 millimeter) high benches. Higher benches will be uncomfortable for many users
- Coordinate bench locations with existing shade trees if possible. Otherwise, install landscaping to



Example of a bench-only stop in Boise, Idaho. The bench is not located on the bus landing pad and does not impede access to the stop.

Source: G. Araki www.the-bus-stops-here.org.



The exterior bench at a stop in Greeley, Colorado is poorly placed, obstructing accessibility on the landing pad and into the shelter. The stop would otherwise be accessible, with a path connecting the stop to the sidewalk and a suitable landing pad, if the bench was not placed in its current location.

Source: Access Compliance Services 2005

³² ADA Accessibility Guidelines for Buildings and Facilities (ADAAG), Section 4.37.

³³ Transit Cooperative Research Program (TCRP) Report 19, 1996.



provide protection from the wind and other elements. Uncomfortable bus stop environmental conditions, such as heat or sun, can discourage use of the bench, forcing patrons to find another place to wait for their bus

- Coordinate bench locations with existing streetlights to increase visibility and enhance security at the stop
- Locate benches on a non-slip, properly drained, concrete pad. Avoid locating benches in undeveloped areas of the right-of-way
- Provide grab handles along the bench for patrons to use as support when standing up (refer to the Rochester, New York photo on page 41 for an example of benches inside a shelter with multiple grab handles)
- Locate benches away from driveways to enhance patron safety and comfort
- Maintain a minimum separation of 24 inches (610 millimeters) (preferably 4 feet or 1,219 millimeters) between the bench and the back-face of the curb. As the traffic speed of the adjacent road increases, the distance from the bench to the curb should be increased to ensure patron safety and comfort
- Maintain general ADA mobility clearances between the bench and other street furniture or utilities at a bus stop
- Avoid installing the bench on the wheelchair landing pad.
- Provide additional waiting room near the bench (preferably protected by landscaping) at bench-only stops to encourage bus patrons to wait at the bus stop
- Avoid metal seating surfaces. Such surfaces are very cold in winter and very hot in summer

Vending Machines³⁴

Vending machines can provide passengers with reading material while they wait for the bus. However, for local, non-commuter routes, vending machines can be undesirable for the following reasons:

- The machines are often poorly maintained and reduce the amount of room for mobility and waiting; and
- Trash accumulates at bus stops with vending machines. Trash removal is time-consuming and costly.

³⁴ Transit Cooperative Research Program (TCRP) Report 19, 1996.

Transit agencies have limited regulatory authority concerning the placement of vending machines. Newsprint companies usually seek high-profile sites to locate their machines. Transit agencies should review the need for the installation of vending machines at bus stops or coordinate with their jurisdiction to implement a consolidated vending rack program. The benefits to patrons of having the machines near the stop versus having to maintain trash receptacles and keep the area free of improperly disposed material should be considered.

If vending machines are provided, they should be anchored to the ground to reduce vandalism. ADA mobility guidelines should be followed for improved site circulation. Vending machines, newspaper boxes and other street furniture cannot reduce the minimum clear spaces required by ADAAG.

Bicycle Storage Facilities³⁵

Bicycle storage facilities, such as bike racks, may be provided at bus stops for the convenience of bicyclists using transit. Designated storage facilities discourage bicycle riders from locking bikes onto the bus facilities or on an adjacent property. Proper storage of bicycles can reduce the amount of visual clutter and ensure a clear pathway. ADA mobility guidelines should be followed in bicycle storage placement.

Trash Receptacles³⁶

Trash receptacles can improve the appearance of a bus stop by providing a place to dispose of trash. The installation of trash receptacles is typically a system-wide decision and the size, shape, and color reflect transit agency or public works department policy. ADA mobility guidelines should be followed in receptacle placement to ensure circulation.

Shopping Cart Storage³⁷

Proper storage for shopping carts at bus stops adjacent to commercial shopping centers is needed. Because such bus stops normally do not have storage facilities for shopping carts, carts often litter the area



The consolidated vending racks in Berkeley, California contain various publications, including newspapers and rental magazines.

Source: Nelson/Nygaard Consulting Associates

³⁵ Transit Cooperative Research Program (TCRP) Report 19, 1996.
³⁶ Ibid.
³⁷ Ibid.



This transit center in Lakewood, Washington, provides an area to store shopping carts to help prevent random placement of carts in and around the center.

Source: Pierce Transit

around the stop and along the sidewalk leading to the stop. The sight of haphazardly placed shopping carts around a bus stop is visually unappealing and can block sidewalk accessibility.

Since shopping carts are generated by the shopping center, agreements should be made between the landowner and the transit agency to remove the carts regularly. One solution is to install a storage facility near the bus stop to prevent random storage in and around the stop. Factors affecting installation of a storage facility include the location of the sidewalk, available right-of-way, utilities, landscaping, terrain, and cost. Any cart storage facility should follow ADA circulation guidelines and remain clear of the sidewalk and wheelchair landing pad area.

Communications

Public telephones

Accessibility & Safety Benefits

Telephones at bus stops offer many potential benefits for bus patrons, including the ability to make personal and emergency calls while waiting for the bus.

Minimum ADA Requirements³⁸

Provide telephones that adhere to the following:

- Where public telephones are provided, at least one telephone should be accessible by persons using wheelchairs. It must be located so that the receiver, coin slot and control are no more than 48 inches (1,219 millimeters) above the floor;
- A clear floor or ground space at least 30 inches by 48 inches (762 millimeters by 1,219 millimeters), not impeded by bases, enclosures, and fixed seats, that allows either a forward or parallel approach by a person using a wheelchair;
- The highest operable part of the telephone and telephone books within the reach ranges specified in ADAAG Sections 4.2.5 or 4.2.6;
- Location follows guidelines detailed in the section on Accessible Path;
- Hearing Aid Compatible and Volume Control equipped in Accordance with ADAAG Section 4.1.3; and
- Length of cord a minimum of 29 inches (735 millimeters) long.

³⁸ ADA Accessibility Guidelines for Buildings and Facilities (ADAAG), Section 4.31.

Universal Design³⁹

Experience with pay phones at bus stops has given mixed results. For example, inclusion of phones at bus stops can create opportunities for illegal or unintended activities, such as drug dealing and loitering, compromising the safety in and around bus stops. Loitering by non-bus patrons at bus stops appears to increase with the installation of phones; this may discourage bus patrons from using the facility.

When locating a phone at a bus stop, the following guidelines should be considered:

- Separate the phone and the bus stop waiting area by a short distance when possible
- Remove the return phone number attached to the phone
- Limit the phone to outward calls only

Police Call Box

Police call boxes for transit systems are typically placed in rail stations or at large bus terminals. Providing call boxes at bus stops aids in establishing a safe environment, especially at stops that are less patronized or are located in suburban and rural areas.

Call boxes are an alternative to public telephones. They require less maintenance and do not encourage loitering by non-bus patrons. Police response is improved as call boxes may be geographically identified instantly in the event of an emergency.

Call boxes must not obstruct access to the stop and must be suitable for users with hearing impairments and those using a wheelchair.



Example of a police call box.

Source: Greater Cleveland Regional Transit Authority Police, <http://www.gcrtc.org/crimepre.asp>

³⁹ Transit Cooperative Research Program (TCRP) Report 19, 1996.



Identifying a Bus Stop by People with Visual Impairments

For people with visual disabilities to distinguish a bus stop from other street furniture, unique features should be incorporated into the design of each bus stop. Stops that have shelters are more readily identifiable due to the unique features of the shelter. However, bus stops that are identified only with a flag pole or that have the flag mounted on a utility pole can be difficult to identify. To address this issue, a pole design that is unique to bus stops should be provided at all locations. For example, the pole may be square with holes running down its length. If a unique pole is provided, the transit agency should educate customers who have visual impairments about this feature.

Maintenance of Bus Stops and Shelters

Maintenance is crucial to establishing and maintaining a barrier free bus stop environment. Trash and broken panel glass can reduce accessibility to a stop by obstructing the path of travel. Additionally, a poorly maintained stop presents an unfavorable image of the agency and may lead to crime. Stops left dirty or shelters left broken create unsafe conditions, sending a message that no one is in control of the stop and is thus open to crime.⁴⁰

Bus stop maintenance can be costly and time-consuming. Working agreements with local businesses or commercial centers can reduce the financial responsibilities of the transit agency or public works department. For stops next to convenience stores, the transit or public works agency should try to obtain a working agreement with the local store or businesses to provide trash removal and general maintenance at the bus stop. This should include snow removal.

Adopt-a-Stop programs are an effective way to maintain bus stops and provide informal community surveillance. King County Metro in Seattle, Washington, administers an Adopt-a-Stop program for maintaining bus stops and shelters. The agency installs the trash can at the stop and provides liners to the local program participant. The individual keeps the stop clean and empties the trash can in exchange for a monthly pass. The program has experienced success with the participation of several hundred individuals.⁴¹

Tri-Met in Portland, Oregon compensates its Adopt-a-Stop participants with ten bus tickets per month for maintaining their stops. More than 800 bus stops within Tri-Met's service area have been adopted, and litter reduced by 80 percent through the program.⁴² Tri-Met outlines their maintenance procedures in their Bus Stop Guidelines 2002, which is reproduced in Appendix B.

Maintenance requirements and resistance to vandalism are important considerations in the selection of an appropriate transit shelter. Most shelters are designed to minimize both of these concerns and

⁴⁰ Loukaitou-Sideris, Anastasia, *Hot Spots of Bus Stop Crime: the Importance of Environmental Attributes*.

⁴¹ Nelson/Nygaard, Interview with Ross Hudson, King County Metro.

⁴² Volinski, Joel and Tucker, Lisa E, *Safer Stops for Vulnerable Customers* 2003.

Adopt-a-Stop programs are an effective way to maintain bus stops and provide informal community surveillance. Participation can be high if incentives are given, such as bus passes.



The glass panels of this bus shelter are raised above the ground to accommodate cleaning, but not so high as to create a problem for white cane users. Picture taken in Toronto, Canada.

Source: SUNY Buffalo

To ensure regular maintenance, a database can be created to track the condition of the facilities.

servicing costs should therefore be minimal.⁴³ To enhance ventilation and to reduce the clutter that can accumulate inside a shelter, a 6-inch (152 millimeter) clearance between the ground and the bottom of the panels is standard in fully enclosed shelters.⁴⁴

To ensure regular maintenance, a database containing maintenance schedules can be created to track the condition of the facilities, including pavement surface conditions; age of the facilities; history of damage; and condition of shelter, benches, or other transit amenities. This information can be collected during the bus stop assessment. The maintenance database can be linked as a subsection of the bus stop inventory database.



Although snow has been removed from the entrance to the shelter and the bus landing pad, this bus stop in Toronto, Canada appears to be the collection area for the plowed snow. This conveys a poor message about the value of the bus stop and shelter. Additionally, the restaurant sign obstructs the sight lines of a wheelchair user.

Source: SUNY Buffalo

⁴³ British Columbia Transit Municipal Systems Program.
⁴⁴ Transit Cooperative Research Program (TCRP) Report 19, 1996.

KEY PLAYERS AND AGENCY COORDINATION

Since bus stops are located on public property, several players are involved in construction, improvements and maintenance. Therefore, partnerships between the transit agency, the public and municipal departments are valuable in providing accessible and safe bus stops.

Generally, transit agencies can benefit from partnerships with the following for bus stop improvements:

- Public Works departments
- City/Municipal offices
- Disability, paratransit offices and advocacy groups
- Businesses and developers
- General public

Partnerships with the public are helpful in maintaining stop accessibility. Through programs such as the previously mentioned Adopt-a-Stop, the public can assist in the maintenance of the bus stop by agreeing to pick up litter, clean the stop amenities and report any items needing repair. Tri-Met in Portland, Oregon, compensates individuals in their Adopt-a-Stop program with gloves, cleaning supplies and a steady supply of bus tickets. These types of partnerships are also successful with businesses and developers.⁴⁵

Examples of interagency coordination are provided in Appendix C.



⁴⁵ Tri-Met, *Bus Stop Guidelines* 2002.



Interdepartmental Collaboration

In addition to cooperating with municipal offices and agencies, implementing bus stop improvements is better facilitated by strong organization within the transit agency. An effective example from Tri-Met is provided in Appendix C.

Bus operators are often well-informed about safe locations for pulling over a bus, and should be consulted by planners responsible for bus stop design and location. Bus operators could then pull the bus over easily and serve customers with disabilities more effectively.

DRIVER TRAINING AND SUPPORT

Effective driver training can go a long way in providing accessible and safe service. Training programs may include:⁴⁶

- Sensitivity and awareness training for all transit personnel who come into contact with the public
- Discussion of different causes and characteristics of mobility, hearing, visual and cognitive disabilities
- Demonstration and hands-on experience with any technologies used, such as wheelchairs, hearing aids, white canes, guide dogs and assistive listening devices. Driver sensitivity classes can include the use of opaque glasses to help increase driver awareness and sensitivity towards people with visual impairments
- Training on the fundamentals of communication with persons with hearing impairments and some basic sign language
- Training on orientating visually impaired persons. The operator needs to give explicit directions when people with visual impairments are looking for a vacant seat or departing the vehicle
- Training on safety concerns related to loading and unloading wheeled mobility device users at bus stops

Reducing Bus Operator Tasks

Bus operators are responsible for many tasks besides driving. The introduction of new technology can help free up time for bus drivers to help patrons with disabilities. According to the ADA, drivers are required to announce major intersections and other specific bus stops, operate wheelchair lifts, assist passengers boarding the lift or ramp and secure wheelchairs and scooters. As part of their operator responsibilities, they must give schedule information, handle any difficult passenger situations and monitor the fare box. These responsibilities are in addition to negotiating traffic, making transfers, staying on schedule, and changing destination signs. Some of the tasks mentioned above could be replaced by technology, such as automatic changing of destination signs and automated intersection announcements.⁴⁷



The ADA requires drivers to announce major intersections and other specific bus stops, operate wheelchair lifts, assist passengers boarding the lift or ramp and secure wheelchairs and scooters.

⁴⁶ Hunter-Zaworski, Katharine M. and Hron, Martha, *Improving Bus Accessibility Systems for Persons with Sensory and Cognitive Impairments* 1993.

⁴⁷ Ibid.



This photo illustrates how guidance lines can be incorporated at a stop (*note: in this U.K. example, the bus travels on the other side of the street, but the guidance line principle can be applied in a U.S. context*).

Source: University College London.
<http://www.cts.ucl.ac.uk/arg/projects/excalib1.htm>

Cooperation Between Drivers and Bus Stop Planners

Pulling flush to the curb at a bus stop can be a challenging task for bus drivers. One option to assist drivers in pulling to the curb is painting a guidance line in the roadway to help the driver maintain the proper approach angle to position the bus parallel to the curb. The EXCALIBUR Project in London experiments with guidance lines at a prototype bus stop. The picture on the left shows an EXCALIBUR bus stop with guidance lines and bus cage that are color separated from the rest of the road.⁴⁸

Automated docking systems are another form of technology that can be used to help the driver pull in parallel at a bus stop to better assist boarding and alighting. Automated precision bus docking allows a bus to consistently pull up to a bus stop at precisely the desired distance to the curb, using a magnetic marker or laser guidance system. A discussion of these technologies can be found in the Technology Section.

⁴⁸ Tyler, Nick, Caiaffa Martha, *Design of Fully Accessible Bus Stops Infrastructure Elements for Buses and Drivers* Centre for Transport Studies, University College London.

TECHNOLOGY AND PRODUCT LINKS

Innovations in transit and wayfinding technology provide improved accessibility and safety for all users of bus systems. These include:

- Talking Signs
- Automated Docking Systems
- Side Collision Warning Systems
- NextBus
- i-Stop

Talking Signs® Technology

Remote infrared audible signs, or RIAS, allow people who are print disabled to directly know what and where objects are located. Unlike Braille, raised letters, or voice signs which passively label a location or give instructions to a specific goal, the remote signage technology developed at the Smith-Kettlewell Eye Research Institute (Talking Signs®) provides a repeating, directionally selective voice message which originates at the sign and is transmitted by infrared light to a hand-held receiver some distance away. To learn more about the technology, visit the Smith-Kettlewell Eye Research Institute website located at <http://www.ski.org/Rehab/WCrandall/introts.html>. The website contains reports detailing Talking Signs® research and tests.

Automated Docking Systems

Automated precision bus docking allows a bus to consistently pull up to a bus stop at precisely the desired distance to the curb, using a magnetic marker or laser guidance system.

The California Partners for Advanced Transit and Highways (PATH) at the University of California, Berkeley tested their automated precision bus docking system at Houston Metro. Their technology utilized magnetic markers onto which the bus could automatically latch and perform either fully automated or semi-automated docking. Their demonstration showed that automated docking exceeded human performance in precision and consistency. Potential applications of the PATH magnetic marker guidance system for bus operations include docking, automated bus daily maintenance, and “Bus Rapid Transit.”⁴⁹

⁴⁹ Partners for Advanced Transit and Highways (PATH). *Precision Docking System Demonstration at Houston*. Intellimotion, Vol. 7, No. 3. 1998.





Carnegie Mellon University in association with Université Blaise-Pascal developed a multiple sensor fusion for detecting the location of curbs, walls, and barriers. The researchers utilized a laser line striper, a vehicle state estimator, a video camera, and a laser scanner to detect the object at one location, track it alongside the vehicle, and search for it in front of the vehicle. The study showed that data from a laser line striper fused with vehicle state estimation, video image, and object detection gave reliable measurements of continuous objects alongside the vehicle. These systems can provide the driver with a higher degree of control and can prevent collisions.⁵⁰

For more information on both the systems, refer to the following websites:

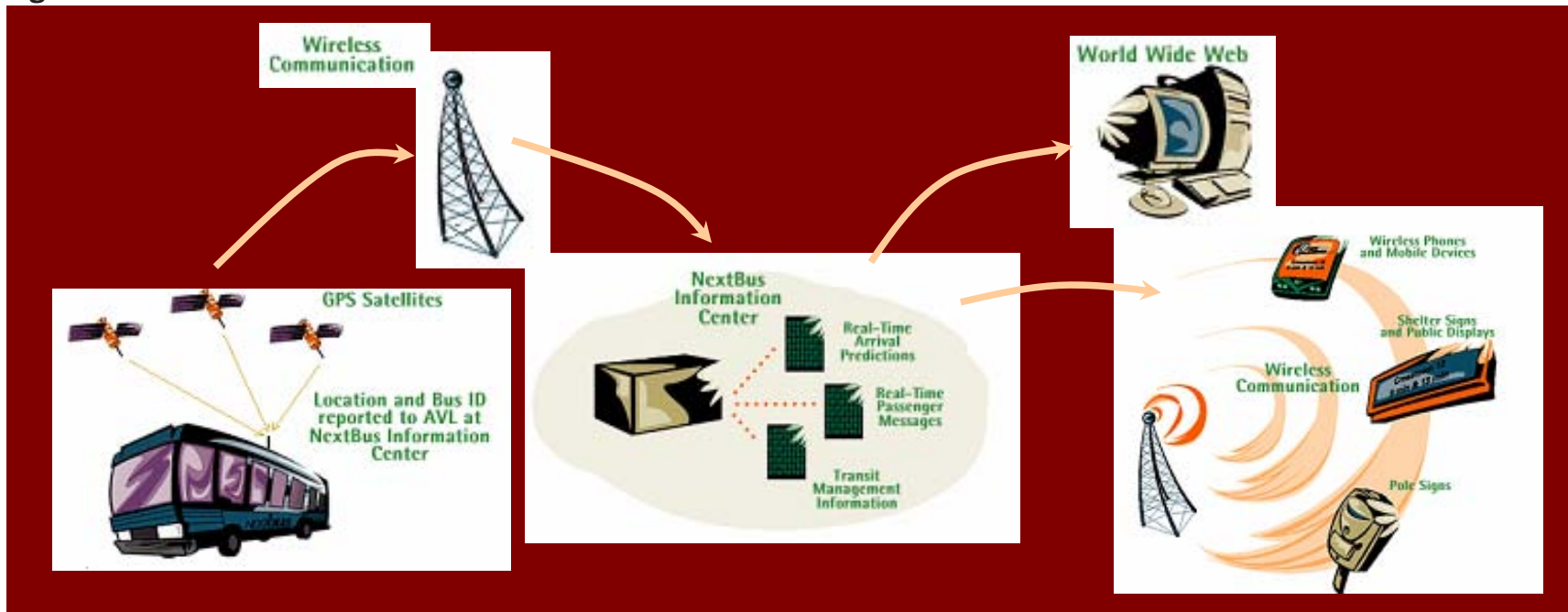
- PATH: <http://www.path.berkeley.edu/PATH/Intellimotion/intel73.pdf>
- Robotics Institute: http://www.ri.cmu.edu/pub_files/pub3/aufriere_romuald_2003_1/aufriere_romuald_2003_1.pdf

⁵⁰ Aufrère, Romuald, Mertz, Christoph, and Thorpe, Charles. Multiple Sensor Fusion for Detecting Location of Curbs, Walls, and Barriers. Proceedings of the IEEE Intelligent Vehicles Symposium (IV2003). 2003.

NextBus

NextBus uses Global Positioning System (GPS) tracking satellites to provide vehicle arrival information and real-time maps, not just bus schedules, to passengers and managers of public transit, shuttles, and trains. The flow of information is diagrammed in Figure 2.

Figure 2. NextBus Information Flow



Source: AC Transit

NextBus information provides actual arrival information, updated at regular intervals to account for traffic variations, breakdowns, and other day-to-day problems faced by any transit provider. The information displays can be installed in bus stop shelters as shown in Figure 3.

Figure 3. Bus Information Display



Source: AC Transit

Technology is now available that provides information to passengers through an audio broadcast, which may provide route or “next-bus” information. This information may be accessed by all passengers by pushing a button on the stop ID pole or may be limited to passengers holding a coded transmitter. This technology should also be combined with a visual display of route information to be accessible to all transit users.

For more information refer to the following website: www.nextbus.com.

i-Stops

i-Stops are solar-powered bus-stop illumination systems featuring a flashing beacon that notifies bus drivers of a stop request, overhead security lighting and an illuminated transit timetable. The i-Stops are self-contained with solar-charging during the day, and are activated by bus patrons after dark with touch switches. i-STOPS are commonly utilized at stops located in less developed areas with minimal lighting or fast moving traffic, mainly located in suburban and rural areas. Options to activate i-Stops with sensors instead of touch switches provide a better alternative for people with visual impairments.

For more information refer to the following website: <http://transitlights.com>.

Bus Stop Shelter Product Links

A variety of transit shelter types are readily available. The following are some of the companies that specialize in bus stop furniture and shelters:

- **JCDecaux**
 - ✧ Products: Street furniture including benches, bus shelters and advertising panels.
 - ✧ Website: <http://www.jcdecaux.co.uk/city/design>
- **Cemusa**
 - ✧ Products: Street furniture including benches, bus shelters, kiosks and trash receptacles.
 - ✧ Website: <http://www.cemusa.com>
- **Tolar Manufacturing Company Inc**
 - ✧ Products: Benches, bus shelters and kiosks and trash receptacles.
 - ✧ Website: <http://www.tolarmfg.com/product.htm>
- **Daytech MFG. LTD.**
 - ✧ Products: Benches, bus shelters, kiosks and map and schedule frames.
 - ✧ Website: <http://www.daytechlimited.com>



Example of an i-Stop.

Source: Carmanah, <http://www.transitlights.com/content/products/i-STOP/default.aspx>



- **Carmanah**
 - ✧ Products: Solar powered bus shelter, solar powered bus stop and bus signaling device.
 - ✧ Website: <http://www.transitlights.com/content/products/Default.aspx>
- **Simme LLC**
 - ✧ Products: Bus stop seating
 - ✧ Website: <http://simmeseat.com>
- **Sepco Plc**
 - ✧ Products: Solar powered bus shelters, stops, flags and advertising
 - ✧ Website: <http://www.sepcopl.com>

URBAN AND RURAL BUS STOPS⁵¹

The design and accessibility of urban and rural bus stops should reflect differences in demographics, density, and land use. Urban areas⁵² are more likely to have continuous sidewalks and high transit ridership compared to rural areas.⁵³ Since rural areas and urban clusters⁵⁴ have proportions of people with disabilities that are comparable to urbanized areas (refer to Figure 4), ensuring that the bus stop is accessible and safe even if continuous sidewalks are not available, is equally important.

Population with Disabilities in Urban and Rural Areas

Census data show that the percentage difference between populations with disabilities living in urban, suburban or rural areas is minimal. Applying accessibility improvements to bus stops is therefore equally valuable in rural areas as it is in suburban and urban areas. Refer to the Creating Accessible and Safe Bus Stops section for rural bus stop design guidelines.

Figure 4 shows the 2000 Census distribution of people in urban and rural areas. Approximately 10.9 million (20 percent) of the almost 55 million rural Americans aged five or older have a disability, while urban clusters have the highest proportion of the population with a disability, over 21 percent. These two categories are often combined by transportation authorities into a broader definition of rural. In this regard, there are about 89 million residents living in rural transportation areas, 16.5 million (20 percent) of whom have a disability.



⁵¹ Research and Training Center on Disability in Rural Communities, the University of Montana Rural Institute, *Update on the Demography of Rural Disability Part One: Rural and Urban 2005*.

⁵² Urban: Territory, population and housing units located within urbanized areas and urban clusters.

⁵³ Rural areas: Territory, population, and housing units located outside of urbanized areas or urban clusters. Rural areas have fewer than 2,500 people or areas where people live in open country.

⁵⁴ Urban Cluster: A densely settled area with a census population of 2,500 to 49,999.



A rural bus stop in Willows, California situated on an unpaved area. The stop is located a considerable distance away from the road, requiring either the patron to walk to the road's edge or the bus to pull off the road.

Source: G. Araki www.the-bus-stops-here.org.



This bus stop in Missoula, Montana is not accessible. It lacks a bus landing pad and accessible path, forcing riders to wait on the road. Additionally, the slope of wheelchair ramp from the bus to the ground will be too steep for wheelchair users to board the bus. Furthermore, placing the bus stop pole in landscaping off the side of the road makes it difficult for a user with visual impairments to locate the stop.

Source: Alexandra Enders, University of Montana

Figure 4. Disability Demographics in Urban and Rural America

	Total population (millions)	Civilian, non-institutionalized population, 5 years and older		
		Total number	Number with a disability	Percent with a disability
United States	281.5	257.2	49.7	19.3%
Urban	222.3	202.5	38.9	19.2%
Urbanized areas*	192.3	175.8	33.2	18.9%
Urban clusters	30.0	26.7	5.7	21.3%
Rural	59.0	54.6	10.9	19.9%
Rural Transit (Rural + Urban Clusters)	89.0	81.3	16.5	20.3%

* Urbanized area: A densely-settled area with a Census population of at least 50,000. A typical urbanized area has more than 500 people per square mile and consists of all or part of one or more incorporated places, such as towns.

Rural Bus Stops⁵⁵

In rural and isolated suburban areas, it is not uncommon to have paved roads with open ditches along the sides to channel storm water. Some of these areas have sidewalks, but most do not, and pedestrians are required to walk on the shoulder of the road. The shoulder often has a steep slope and is comprised of loose material such as gravel and dirt.

Municipalities typically have capital works programs to replace the open ditches with storm sewers. Given the capital cost of such an upgrading, the elimination of ditches and the provision of sidewalks will be a long-term objective in many instances. Transit riders, in the interim, have to board buses without the benefit of a curb to lift them closer to the first step of the bus. Additionally, transit passengers have to get on and off a bus on a gravel or dirt surface. This boarding and unloading situation is very difficult for older adults and especially for those using wheelchairs or other mobility devices.

To best accommodate rural and suburban transit users with disabilities, installing a concrete or asphalt pad on the shoulder of the road is a possible solution to create an accessible bus stop. The pad must be elevated 6 inches (150 millimeters) above road grade for both safety and accessibility purposes. The curb cut between the pad and the road grade must follow the ADA guidelines. Although the elevated pad creates grade changes, it is a preferred scenario to differentiate between vehicle and pedestrian rights-of-way, increasing pedestrian safety. The pad must follow regulations given in the Bus Stop Platforms and Bus Landing Pads section.

⁵⁵ BC Transit Municipal Systems Program, *Design Guidelines for Accessible Bus Stops*.

APPENDICES



APPENDIX A. QUICK BUS STOP CHECKLIST

QUICK BUS STOP CHECKLIST

<i>Route Name:</i>	<i>Location:</i>	<i>Weather Conditions:</i>	<i>Stop No.:</i>
--------------------	------------------	----------------------------	------------------

PART A: IDENTIFICATION/LOCATION							
A1	Street Name:						
A2	Nearest Cross Street (street name or landmark if mid-block):						
A3	Bus Route Direction:						
	<table border="1"> <tr> <td>North Bound <input type="checkbox"/></td> <td>South Bound <input type="checkbox"/></td> <td>More than one direction <input type="checkbox"/></td> </tr> <tr> <td>East Bound <input type="checkbox"/></td> <td>West Bound <input type="checkbox"/></td> <td></td> </tr> </table>	North Bound <input type="checkbox"/>	South Bound <input type="checkbox"/>	More than one direction <input type="checkbox"/>	East Bound <input type="checkbox"/>	West Bound <input type="checkbox"/>	
	North Bound <input type="checkbox"/>	South Bound <input type="checkbox"/>	More than one direction <input type="checkbox"/>				
East Bound <input type="checkbox"/>	West Bound <input type="checkbox"/>						
A4	Where is the bus stop positioned in relation to the nearest intersection?						
	Nearside (Before the bus crosses the intersection)	<input type="checkbox"/>					
	Far Side (After the bus crosses the intersection)	<input type="checkbox"/>					
	Mid-block or not near an intersection	<input type="checkbox"/>					
	Freeway bus pad	<input type="checkbox"/>					
	N/A	<input type="checkbox"/>					
A5	Distance from bus stop pole to curb in feet:						
A6	Adjacent property address or name of business (only if readily visible):						

<i>Date</i>	<i>Time:</i>	<i>Surveyor:</i>
-------------	--------------	------------------

QUICK BUS STOP CHECKLIST

<i>Route Name:</i>	<i>Location:</i>	<i>Weather Conditions:</i>	<i>Stop No.:</i>
--------------------	------------------	----------------------------	------------------

PART B: Landing Area Assessment

B1	Is there a landing area at least 5 feet wide and 8 feet deep adjacent to the curb/street?		Yes <input type="checkbox"/>	No <input type="checkbox"/>	
B2	Where is the landing area positioned in relation to the curb/street?				
	Below street level (low ground or shoulder) <input type="checkbox"/>	Shoulder <input type="checkbox"/>	Other (specify): <input type="checkbox"/>		
	Adjacent <input type="checkbox"/>	Bus Bulb <input type="checkbox"/>	Off-Road/No sidewalk <input type="checkbox"/>		
B3	What is the material of the landing area?				
	Asphalt <input type="checkbox"/>	Dirt <input type="checkbox"/>	Gravel <input type="checkbox"/>	Other (specify): <input type="checkbox"/>	
	Concrete <input type="checkbox"/>	Grass <input type="checkbox"/>	Pavers <input type="checkbox"/>		
B4	Are there problems with the landing area surface?			Yes <input type="checkbox"/>	No <input type="checkbox"/>
	<i>If YES, rank resulting accessibility potential:</i>				
		Not Accessible	Minimally Accessible	Accessible	
	Uneven	<input type="checkbox"/>	<input type="checkbox"/>	<input type="checkbox"/>	
	Slopes up from the street	<input type="checkbox"/>	<input type="checkbox"/>	<input type="checkbox"/>	
	Slopes down from the street	<input type="checkbox"/>	<input type="checkbox"/>	<input type="checkbox"/>	
	Requires stepping over drain inlet	<input type="checkbox"/>	<input type="checkbox"/>	<input type="checkbox"/>	
Other (Specify)	<input type="checkbox"/>	<input type="checkbox"/>	<input type="checkbox"/>		
B5	Are there any obstacles that would limit the mobility of a wheelchair (trash receptacle, newspaper boxes, landscaping, other)?			Yes <input type="checkbox"/>	No <input type="checkbox"/>
	<i>If YES, describe obstruction:</i>				

<i>Date</i>	<i>Time:</i>	<i>Surveyor:</i>
-------------	--------------	------------------

QUICK BUS STOP CHECKLIST

<i>Route Name:</i>	<i>Location:</i>	<i>Weather Conditions:</i>	<i>Stop No.:</i>
--------------------	------------------	----------------------------	------------------

B6	Additional landing area comments:
-----------	-----------------------------------

PART C: PEDESTRIAN COMFORT AMENITIES

Section C-1: Shelters (move to Section C-2 if there is no shelter)

C1	What are the approximate dimensions (width, height and depth in feet) of the interior standing area?							
	Width:							
	Height:							
	Depth:							
C2	Could a person using a wheelchair maneuver into the shelter?	Yes <input type="checkbox"/> No <input type="checkbox"/>						
C3	Could a person using a wheelchair fit completely under the shelter (minimum space of a common mobility device is 30 in. by 48 in. (760 mm by 1200mm))?	Yes <input type="checkbox"/> No <input type="checkbox"/>						
C4	What is the distance of the front of the shelter from the curb in feet?							
	<table style="width: 100%; border: none;"> <tr> <td style="border: none;">0 - 2' <input type="checkbox"/></td> <td style="border: none;">2' - 4' <input type="checkbox"/></td> <td style="border: none;">4' - 6' <input type="checkbox"/></td> <td style="border: none;">6' - 8' <input type="checkbox"/></td> <td style="border: none;">8' - 10' <input type="checkbox"/></td> <td style="border: none;">>10' <input type="checkbox"/></td> </tr> </table>	0 - 2' <input type="checkbox"/>	2' - 4' <input type="checkbox"/>	4' - 6' <input type="checkbox"/>	6' - 8' <input type="checkbox"/>	8' - 10' <input type="checkbox"/>	>10' <input type="checkbox"/>	
0 - 2' <input type="checkbox"/>	2' - 4' <input type="checkbox"/>	4' - 6' <input type="checkbox"/>	6' - 8' <input type="checkbox"/>	8' - 10' <input type="checkbox"/>	>10' <input type="checkbox"/>			
C5	Additional shelter comments:							

Section C-2: Seating Assessment (move to Part D if there is no seating)

C6	What is the type of seating available?	
	Bench inside shelter – <i>skip to question C8</i>	<input type="checkbox"/>
	Freestanding bench	<input type="checkbox"/>
	Fold down bench	<input type="checkbox"/>
	Leaning bench	<input type="checkbox"/>
	Other (specify):	<input type="checkbox"/>

<i>Date</i>	<i>Time:</i>	<i>Surveyor:</i>
-------------	--------------	------------------

QUICK BUS STOP CHECKLIST

<i>Route Name:</i>	<i>Location:</i>	<i>Weather Conditions:</i>	<i>Stop No.:</i>
--------------------	------------------	----------------------------	------------------

C7	If not inside shelter, what is the distance of the seating from the curb in feet?					
	<table style="width: 100%; border-collapse: collapse;"> <tr> <td style="width: 15%; text-align: center;">0 - 2' <input type="checkbox"/></td> <td style="width: 15%; text-align: center;">2' - 4' <input type="checkbox"/></td> <td style="width: 15%; text-align: center;">4' - 6' <input type="checkbox"/></td> <td style="width: 15%; text-align: center;">6' - 8' <input type="checkbox"/></td> <td style="width: 15%; text-align: center;">8' - 10' <input type="checkbox"/></td> <td style="width: 15%; text-align: center;">>10' <input type="checkbox"/></td> </tr> </table>	0 - 2' <input type="checkbox"/>	2' - 4' <input type="checkbox"/>	4' - 6' <input type="checkbox"/>	6' - 8' <input type="checkbox"/>	8' - 10' <input type="checkbox"/>
0 - 2' <input type="checkbox"/>	2' - 4' <input type="checkbox"/>	4' - 6' <input type="checkbox"/>	6' - 8' <input type="checkbox"/>	8' - 10' <input type="checkbox"/>	>10' <input type="checkbox"/>	
C8	Rank the condition of the seating:					
	<table style="width: 100%; border-collapse: collapse;"> <tr> <td style="width: 15%; text-align: center;">1 <input type="checkbox"/></td> <td style="width: 15%; text-align: center;">2 <input type="checkbox"/></td> <td style="width: 15%; text-align: center;">3 <input type="checkbox"/></td> <td style="width: 15%; text-align: center;">4 <input type="checkbox"/></td> <td style="width: 15%; text-align: center;">5 <input type="checkbox"/></td> </tr> </table> <p style="font-size: small; margin-top: 5px;"> <i>1=hazardous – broken, someone could get hurt from normal use</i> <i>2=in poor shape though not hazardous</i> <i>3=fair – needs repainting, needs cosmetic attention,, protruding but not hazardous bolts</i> <i>4=good – not perfect but no immediate repair need</i> <i>5=cosmetically excellent; new</i> </p>	1 <input type="checkbox"/>	2 <input type="checkbox"/>	3 <input type="checkbox"/>	4 <input type="checkbox"/>	5 <input type="checkbox"/>
1 <input type="checkbox"/>	2 <input type="checkbox"/>	3 <input type="checkbox"/>	4 <input type="checkbox"/>	5 <input type="checkbox"/>		
C9	Additional seating comments:					

PART D: Information Features

D1	Is there a bus stop sign?	Yes	No
	<i>If NO, move to question D5.</i>	<input type="checkbox"/>	<input type="checkbox"/>
D2	Are bus routes indicated on the bus stop sign?	Yes	No
	<i>If YES, what routes?</i>	<input type="checkbox"/>	<input type="checkbox"/>
D3	How is the sign installed?		
	On its own pole	<input type="checkbox"/>	
	On a building	<input type="checkbox"/>	
	On a utility pole	<input type="checkbox"/>	
	On a shelter	<input type="checkbox"/>	
	Other (specify):	<input type="checkbox"/>	

<i>Date</i>	<i>Time:</i>	<i>Surveyor:</i>
-------------	--------------	------------------

QUICK BUS STOP CHECKLIST

<i>Route Name:</i>	<i>Location:</i>	<i>Weather Conditions:</i>	<i>Stop No.:</i>
--------------------	------------------	----------------------------	------------------

D4	Are there problems with the signage?	Yes No <input type="checkbox"/> <input type="checkbox"/>
	<i>If YES, check all that apply:</i>	
	Sign in poor condition	<input type="checkbox"/>
	Pole in poor condition	<input type="checkbox"/>
	Sign position hazardous to pedestrians	<input type="checkbox"/>
	Sign not permanently mounted	<input type="checkbox"/>
	Lighting on sign is poor	<input type="checkbox"/>
	Other (specify):	<input type="checkbox"/>
D5	Is there route/schedule/map (circle as appropriate) information posted?	Yes No <input type="checkbox"/> <input type="checkbox"/>
	<i>If NO, skip to Question D8</i>	
D6	Where is the route/schedule/map (circle as appropriate) information posted?	
	On pole under bus stop sign	<input type="checkbox"/>
	On its own pole	<input type="checkbox"/>
	On a building	<input type="checkbox"/>
	On a utility pole	<input type="checkbox"/>
	On a shelter	<input type="checkbox"/>
	In a shelter	<input type="checkbox"/>
	Other (specify):	<input type="checkbox"/>
D7	Is the information at eye level of a wheelchair user?	Yes No <input type="checkbox"/> <input type="checkbox"/>
D8	Additional signage & information comments:	

<i>Date</i>	<i>Time:</i>	<i>Surveyor:</i>
-------------	--------------	------------------

QUICK BUS STOP CHECKLIST

<i>Route Name:</i>	<i>Location:</i>	<i>Weather Conditions:</i>	<i>Stop No.:</i>
--------------------	------------------	----------------------------	------------------

PART E: Other Amenities

E1	What other amenities are at the bus stop?	
	Trash receptacle	<input type="checkbox"/>
	Telephone or police call box	<input type="checkbox"/>
	Newspaper boxes	<input type="checkbox"/>
	No other amenities	<input type="checkbox"/>
	Other (specify):	<input type="checkbox"/>
E2	Do any of these amenities block wheelchair access?	Yes No <input type="checkbox"/> <input type="checkbox"/>
	<i>If YES, specify what the amenity is blocking access to:</i>	
	Bus shelter	<input type="checkbox"/>
	Wheelchair seating area	<input type="checkbox"/>
	Bus ingress or egress	<input type="checkbox"/>
	Bus stop information	<input type="checkbox"/>
	Other (specify):	<input type="checkbox"/>

PART F: Traffic and Pedestrian Safety Issues

Section F-1: Traffic and Pedestrian Issues

F1	Where is the bus stop area located?	
	In travel lane	<input type="checkbox"/>
	Bus lane/pull off area	<input type="checkbox"/>
	Paved shoulder	<input type="checkbox"/>
	In right turn only lane	<input type="checkbox"/>
	Unpaved shoulder	<input type="checkbox"/>
	Off street	<input type="checkbox"/>
	"No Parking" portion of street parking lane	<input type="checkbox"/>
	Other (specify):	<input type="checkbox"/>

<i>Date</i>	<i>Time:</i>	<i>Surveyor:</i>
-------------	--------------	------------------

QUICK BUS STOP CHECKLIST

<i>Route Name:</i>	<i>Location:</i>	<i>Weather Conditions:</i>	<i>Stop No.:</i>
--------------------	------------------	----------------------------	------------------

F2	Is the bus stop zone designated as a no parking zone?	Yes No <input type="checkbox"/> <input type="checkbox"/>
	<i>If YES, indicated by:</i>	
	One "No Parking" sign	<input type="checkbox"/>
	2 or more "No Parking" signs	<input type="checkbox"/>
	"Bus Only" sign	<input type="checkbox"/>
	Painted curb	<input type="checkbox"/>
	Painted street	<input type="checkbox"/>
F3	Are cars parked between the landing area and the bus stopping area?	Yes No <input type="checkbox"/> <input type="checkbox"/>
F4	What is the posted speed limit in MPH?	Not posted <input type="checkbox"/>
F5	What are the traffic controls at the nearest intersection for the street?	
	Traffic signals	<input type="checkbox"/>
	Flashing lights	<input type="checkbox"/>
	Stop/Yield sign	<input type="checkbox"/>
	None	<input type="checkbox"/>
	Other (specify):	<input type="checkbox"/>
F6	How many total lanes are on both sides of the road?	
	1 <input type="checkbox"/> 2 <input type="checkbox"/> 3 <input type="checkbox"/> 4 <input type="checkbox"/> Other (specify): <input type="checkbox"/>	N/A <input type="checkbox"/>
F7	Are there potential traffic hazards?	Yes No <input type="checkbox"/> <input type="checkbox"/>
	<i>Yes, check all that apply:</i>	
	The bus stop is just over the crest of a hill	<input type="checkbox"/>
	The bus stop is just after a curve in the road	<input type="checkbox"/>
	The bus stop is near an at-grade railroad crossing	<input type="checkbox"/>
	Waiting passengers are hidden from view of approaching bus	<input type="checkbox"/>
	A stopped bus straddles the crosswalk	<input type="checkbox"/>
	Bus stop just before crosswalk	<input type="checkbox"/>
High speed traffic	<input type="checkbox"/>	

<i>Date</i>	<i>Time:</i>	<i>Surveyor:</i>
-------------	--------------	------------------

QUICK BUS STOP CHECKLIST

<i>Route Name:</i>	<i>Location:</i>	<i>Weather Conditions:</i>	<i>Stop No.:</i>
--------------------	------------------	----------------------------	------------------

	No crosswalk	<input type="checkbox"/>
	Other (specify)	<input type="checkbox"/>
F8	Additional traffic safety comments / recommendations:	

Section F-2: Lighting Assessment (assessment preferably taken in the evening or at night)
Go to Part G if no lighting

F9	What type of lighting is available?	
	Street light	<input type="checkbox"/>
	Shelter lighting	<input type="checkbox"/>
	Outside light on adjacent building	<input type="checkbox"/>
	Other (specify):	<input type="checkbox"/>
F10	Additional comments:	

PART G: Getting to the Bus Stop

G1	How wide is the sidewalk?				
	No sidewalk <input type="checkbox"/>	less than 3' <input type="checkbox"/>	3'-5' <input type="checkbox"/>	5' or greater <input type="checkbox"/>	N/A <input type="checkbox"/>
G2	Rank the condition of the sidewalk:				
	1 <input type="checkbox"/>	2 <input type="checkbox"/>	3 <input type="checkbox"/>	4 <input type="checkbox"/>	5 <input type="checkbox"/>
	<i>1=hazardous – large breaks, cracks, root uplifting, someone could get hurt from normal use or use of a wheelchair would be difficult</i> <i>2=in poor shape though not hazardous – very rough, some root uplifting, cracks, breaks</i> <i>3=fair – minor root uplifting, minor cracks or breaks</i> <i>4=good – not perfect but no immediate repair</i> <i>5=cosmetically excellent; new</i>				

<i>Date</i>	<i>Time:</i>	<i>Surveyor:</i>
-------------	--------------	------------------

QUICK BUS STOP CHECKLIST

<i>Route Name:</i>	<i>Location:</i>	<i>Weather Conditions:</i>	<i>Stop No.:</i>
--------------------	------------------	----------------------------	------------------

G3	Are there physical barriers that constrict the width of the sidewalk within the block on which the bus stop is located?			Yes <input type="checkbox"/>	No <input type="checkbox"/>		
	<i>If YES, what is the narrowest useable width:</i>						
Less than 3' <input type="checkbox"/>		3' or greater <input type="checkbox"/>					
G4	Does the landing pad connect to the sidewalk?				Yes <input type="checkbox"/>	No <input type="checkbox"/>	
	G5 Where is the nearest street crossing opportunity?						
The nearest intersection <input type="checkbox"/>		Mid-block crosswalk <input type="checkbox"/>					
G6	What pedestrian amenities are at the nearest intersection (or other crossing opportunity)?						
	Curb cuts all corners/ both sides <input type="checkbox"/>	Pedestrian crossing signal <input type="checkbox"/>	Traffic light <input type="checkbox"/>				
	Visible crosswalk <input type="checkbox"/>	Audible crosswalk signal <input type="checkbox"/>	Crossing guard assistance <input type="checkbox"/>				
	Curb cuts at some corners/one side <input type="checkbox"/>	Accessible Pedestrian Signal (APS) <input type="checkbox"/>	Tactile warning strip on curb cut <input type="checkbox"/>				
	Other (specify):					<input type="checkbox"/>	

<i>Date</i>	<i>Time:</i>	<i>Surveyor:</i>
-------------	--------------	------------------



APPENDIX B. TRI-MET MAINTENANCE GUIDELINES⁵⁶

Tri-Met in Portland, Oregon, provides guidelines on maintenance activities in their Bus Stop Guidelines 2002 manual. The agency defines a clean stop as free from:

- Debris, including cigarette butts, cups and newspapers
- Foreign substances, including gum, spills and food
- Insects and weeds
- Graffiti (written or etched)
- Unauthorized stickers or posters

Well-maintained stops reflect the following elements:

- Overall passenger facilities are in good repair
- Areas and improvements are in good condition and all repairs are current
- All amenities (shelters, benches, trash receptacles) are properly installed to meet the requirements of city ordinances and Americans with Disabilities Act (ADA)
- Furniture surfaces are in good condition, including no rust, marring or scratches
- Signage, walls, seating and kiosks are in good condition
- Lighting in good working order at all times
- Free from overhanging trees or brush

Tri-Met's guidelines for repair, maintenance and cleaning are detailed below:

- Repairs are performed by both in-house employees and contractors
- Pick up trash and debris within a 15 feet radius of bus stops (blowers shall not be used)
- Remove graffiti, stickers and unauthorized signs and posters
- Power wash all amenities with water. Using a ladder, clean the shelter roof inside and outside with a soft bristled brush until all dirt has been removed. Clean and flush gutters and drain holes of all debris. Clean the shelter frame, bench and windows (inside and outside) until all dirt has been removed using a soft bristled brush and pressure washer. Dry windows with a squeegee so that no smears or

⁵⁶ Tri-Met, 2002.

streaks remain visible. Wipe benches completely dry after cleaning or graffiti removal to allow immediate customer use and to prevent claims for damaged clothing

- Emergency cleaning – all emergency cleanings shall be completed within four hours of notification, except broken glass, which shall be replaced within two hours notification

Tri-Met operates several public-private partnerships in an effort to keep their stops clear of litter and graffiti. Whenever possible, Tri-Met seeks sponsors to assist with the growing trash problem. In most cases, Tri-Met provides the trash receptacle at a particular shelter. The sponsor collects and disposes of the trash as needed. A plaque on the trash can denotes the sponsor's name. Tri-Met maintains the trash can by providing the liner insert, and repairs and repaints (due to graffiti) on an as-needed basis. In addition, they operate their waste disposal routine.

For locations without sponsors, Tri-Met has its own in-house trash collection crew. The crew follows a regular route schedule and also assists in emergency trash pick-up as needed. When a sponsor neglects a trash can due to moving, vacation, etc., the crew assists until another sponsor is found.

Tri-Met partners with Stop Oregon Litter and Vandalism (SOLV) to provide anti-litter and graffiti programs in addition to the regular maintenance routines described above. The SOLV program consists of three major components:

- **Adopt-a-Stop:** A customer agrees to pick up litter, clean the stop amenities and report any items needing repair in exchange for gloves, cleaning supplies and a steady supply of bus tickets.
- **Keep-a-Can:** If a trash can needs to be cleaned at a particular stop, customers or local businesses can sponsor a trash can. Under the program, volunteers agree to empty and provide service for a trash can. In return, Tri-Met will provide an attractive, industrial strength can, liner and soda can recycling container for the stop.
- **First Step Youth Program:** During the summer, SOLV and Tri-Met organize groups of at-risk students to clean up street litter and graffiti, focusing on Tri-Met transit corridors. Tri-Met provides group payment, supervision and transportation.

Tri-Met's bus stop amenities are monitored and have an established shelf life for replacement as a result of accidents, vandalism or general wear over time. Regular maintenance will extend the life of bus shelters and other bus stop features, but their replacement is eventually required. The Capital Improvement (CIP) identifies the following criteria for the replacement of bus stop shelters:

- Condition compromises customer safety
- Exceeds a 15 year life cycle
- Customer security is in some way compromised
- Parts for repair and maintenance are no longer available
- The shelter is not in compliance with ADA

Bus stop signs are similarly replaced if they pose a safety concern for bus riders; they have been damaged or vandalized; they impede movement with ADA guidelines or exceed an 8-year life cycle. Bus stop features may be in good condition beyond their expected life in which case replacement would be deferred. Signs, shelters and other amenities may be upgraded or moved to reflect changes in bus stop use or coordination with other development projects.



APPENDIX C. CASE STUDIES/EXAMPLES OF AGENCY COORDINATION

City of Winnipeg Transit System's Organizational Support for Bus Stops⁵⁷

The City of Winnipeg Transit System in Canada, provides an example of partnerships that have helped implement bus stop improvements and projects. In 1992, the Mayor of Winnipeg established a Task Force to review the status of the paratransit service (referred to as Handi-Transit) and assess emerging technologies to make the fixed-route bus system accessible. Winnipeg Transit decided to convert their fleet to low floor buses - the first three low-floor buses procured were dedicated to Route 10. Improvements were implemented at the bus stops along the route through the following process:

1. The agency enlisted the support of local area city councilors of cities affected by the route
2. Citizens, accompanied by their city councilors, made safety and accessibility assessments along the route
3. With citizen input, the agency developed guidelines for the Route 10 bus stops which became the blueprint for all bus stops in the system
4. The agency continued the audit internally of all 4,500 stops, based on the input obtained through the Route 10 outreach and accessibility improvements. The guidelines serve as an example to staff and private contractors who are implementing the bus stop improvements

Winnipeg City departments have interdepartmental meetings to coordinate future projects. Construction projects are circulated to all the departments (including Transit and Fire) to obtain feedback. The feedback is then incorporated into the project plan. Bus stop improvements and considerations are therefore incorporated into the project before construction begins. The agency has cultivated a good working relationship with Public Works and Planning Departments and is apprised of sidewalk construction projects at least a year in advance.

⁵⁷ NelsonNygaard, Interview with Alex Regiec, City of Winnipeg Transit System, February 28, 2005.

Tri-Met Organizational Support for Bus Stop Management⁵⁸

Tri-Met in Portland, Oregon uses a comprehensive coordinated plan to ensure bus stop accessibility. Many of the elements of this plan could be replicated at other agencies that may not have placed as much focus on bus stop accessibility.

Public-Private Partnerships

An agreement between Tri-Met and the City of Portland has simplified the siting and permitting process for bus shelters and amenities to allow for quicker installation. Tri-Met encourages developing Intergovernmental Agreements and Memoranda of Understanding with municipal departments as they have improved Tri-Met's ability to provide bus stop accessibility and amenity improvements.

Piggybacking on development projects helps in the implementation of bus stop improvements. Depending on the size and nature of the development, Tri-Met may request improvements to adjacent bus stops. If frontage improvements are planned, Tri-Met will request the addition of an ADA landing pad and a rear door landing pad at stops that lack them. If ridership potential exists, the agency may request the developer provide a bus shelter, a bench or other bus stop amenities as warranted. Developers are also required to maintain the stop free of litter and vandalism.

Interdepartmental Coordination

In addition to cooperating with municipal offices and agencies, implementing bus stop improvements is better facilitated by strong organization within the transit agency. *Tri-Met's Bus Stop Guidelines 2002* provides a good description of the responsibilities of each position and department in implementing bus stop improvements.

Tri-Met developed a carriage walk agreement between the Project Planning Department, which oversees bus stop placement and design, and the Bureau of Maintenance. The Agreement coordinates bus stop accessibility improvements (including ADA landing pads and curb ramps), with the city's efforts to upgrade pedestrian infrastructure (such as curb ramps and accessible sidewalks).

⁵⁸ Tri-Met, 2002.

Capital Projects Management Section of the Project Planning Department is responsible for the design and placement of bus stops, including shelter and amenity placement. The section works closely with other Tri-Met departments to provide for the regular maintenance and management of bus stops as well as implementation of bus stop development programs. The following is a brief description of the Section's positions and their responsibilities:

- **Programs Manager:** Responsible for developing and implementing a 5-year Bus Stops Management and Development Plan, which includes negotiating agreements with each major jurisdiction. The Manager is also responsible for coordinating programs and managing the department and program budgets and contracts. The Capital Programs Management Section, including positions matrixed from other departments, report directly to the Programs Manager for bus stop program related activities.
- **Project Planner:** Provides support for field checks and sign placement. Works with the Programs Manager to develop and update the 5-year Bus Stops Management and Development Plan. Provides the lead support for development and coordination of the Streamline Bus Improvement Program and other agency initiatives. Prepares conceptual designs for bus stop improvements and identifies right-of-way permit requirements for new or modified stops.
- **Maintenance Supervisor:** Assesses and manages the cleaning and repair needs and contracts and is responsible for quality control for these efforts.
- **Engineer:** Works closely with all members of the section but also reports to the Project Implementation Department within the Capital Project and Facilities Division. Using Tri-Met and jurisdiction standards, the Engineer prepares design and construction drawings for all bus stop improvements. The Engineer orders utility checks, works with jurisdictions regarding joint construction or traffic managements issues, establishes specifications for procurement contracts of bus stop shelters, signs and other amenities and oversees their installation.
- **Adopt-a-Stop Program Coordinator:** This person monitors partnership agreements for the servicing of bus stops, shelters and trash receptacles and is a contract employee of Stop Oregon Litter and Vandalism (SOLV).
- **Planner/Analyst:** Responsible for building and maintaining Tri-Met's central bus stops database. This position is a significant resource for the planning, analysis and GIS mapping of bus stops and supporting information. The Planner/Analyst uses a Global Positioning System locator device to accurately locate bus stops within the geographic information system files. This person also prepares status and performance reports to track cleaning, repair, response to complaints and work orders.

- **Community Relations Specialist:** Serves as a central point of contact for all external and internal communications pertaining to bus stop related inquiries. This person prepares mailings and notices for bus stop changes and sets up community meetings pertaining to bus stop programs.

The overall responsibility for bus stops management resides with the Bus Stops Section. However, some issues require review and input from a broad cross-section of Tri-Met divisions.

- The **Service Planning Department**, in concert with the **Scheduling Department**, determines routes and the type of services to be provided along the routes. These have direct bearing on the location and design of bus stops.
- The **Field Operations Supervisors** are in the best position to identify bus stop problems and operational concerns that influence bus stop placement. Road Supervisors request bus stop changes based on field observations and as required to accommodate construction projects or events that cause the realignment of service. They also temporarily reroute service when bus stops are affected by construction activities. Road Supervisors also receive customer comments in the course of their surveillance activities. Similarly, Bus Operators also pass on issues that they identify or comments from their bus riders.
- **Maintenance Technicians** in the Facilities Management Department repair and maintain stops and shelters. Maintenance technicians also receive customer comments in the course of their activities, which are managed within their group or passed to the Bus Stops Section.
- The **Information Development Department** of the Marketing and Customer Service Division prepares specifications for signage and information displays and determines locations for other customer information. The **Marketing Department** manages the shelter and bench advertising programs. Individual requests and needs for bus stop changes funnel through the **Customer Service Department** and are recorded in a Customer Service Inquiry database, which is assessed by the Bus Stops Management Section for research and response. Employer outreach efforts conducted by the Marketing Department provide input for program development.
- Tri-Met's **Committee on Accessible Transportation (CAT)** provides a very important consultative role in the management of bus stops. This committee comments on bus stop design guidelines and the development of standard bus stop features (e.g., bus stop shelter design). This perspective helps to assure compliance with the ADA and helps set priorities for bus stop development programs.
- The **Public Art Program** also provides input for integrating art into bus stop design and in identifying opportunities for unique art projects associated with bus stops.
- Other groups are linked through the internal coordination plan and include **Safety, Training and Real Property**.

APPENDIX D: SAMPLE AGREEMENT FOR PRIVATE ROAD BUS STOP PLACEMENT⁵⁹

Pierce Transit in Tacoma, Washington signs a Private Road Bus Stop Placement Use Agreement with owners of private property on which they would like to locate a stop. The agreement is provided below.

PRIVATE ROAD BUS STOP PLACEMENT USE AGREEMENT

THIS USE AGREEMENT, made and entered into in triplicate, this day of 2005, by and between PIERCE COUNTY PUBLIC TRANSPORTATION BENEFIT AREA CORPORATION, a municipal corporation hereinafter called “Pierce Transit” and which represents the ownership and maintenance of a private road, hereinafter called the “Owner”.

WITNESSETH:

WHEREAS, Owner represents the ownership and maintenance of a private road physically located at and further depicted on attached Exhibit “A”; and

WHEREAS, the Owner has requested that Pierce Transit place a bus stop adjacent to the private road and in a location agreed to by the adjacent property owner, and in accordance with the provisions of this agreement; and,

WHEREAS, the parties herein desire to enter into a general use agreement to allow Pierce Transit access to the described private road and allow placement and use of a bus stop by the public to access public transportation services offered from the described location; and,

WHEREAS, Pierce Transit agrees to provide transportation services to this location in consideration of this access and agreement subject to Pierce Transit’s operating requirements; and,

WHEREAS, this agreement does not guarantee the delivery of any public transportation services to the property.

⁵⁹ Nelson\Nygaard, Interview with Tim Renfro, Pierce Transit, March 28, 2005.

NOW, THEREFORE, in consideration of the covenants and agreements the parties hereinafter set forth, Owner does hereby grant unconditional access and use of the private roadway described above including the placement of a bus stop on Owner's property.

1. Premises. The Owner grants to Pierce Transit the right to use that portion of the Owner's premises shown (called the "Premises") for a public bus stop.
2. Usage Rights Granted. Pierce Transit, at its expense, may install signs, paint markings, and other traffic control devices and make other improvements. All other changes shall require the consent of the Owner.
3. Owner's Rights. The Owner reserves the right to make other uses of the Premises that do not interfere with Pierce Transit's use.
4. Term. The term of this Agreement shall be ongoing commencing on this day of 2005. At any time, either Party may terminate this Agreement by giving two (2) months' notice to the other party of its intent to terminate.
5. Access. Pierce Transit may authorize the use of the Owner's driveways, walkways and improved surfaces surrounding the Premises for vehicular and pedestrian access to the Premises.
6. Maintenance. Pierce Transit shall only be responsible for maintenance of markings and improvements that it installs and will not be responsible for any roadway maintenance and repairs at the Premises location. Owner agrees that they have inspected the location of the bus stop and the adjacent roadway and have determined that the location of the bus stop is a safe location and that the roadway is adequate to accommodate public transit vehicles. Further, Owner will hold Pierce Transit harmless from any damage, claims, actions or losses to the roadway connection with the use of the Premises unless a result of Pierce Transit's sole negligence and to the extent permitted by law.
7. Towing of Vehicles. Pierce Transit may order vehicles to be towed away at its own expense and risk. Special consideration, however, shall be provided for vehicles displaying a government-issued "handicapped" license plate or decal.

8. Insurance. Pierce Transit will procure and maintain, for the duration of the Agreement, insurance and/or self-insurance against claims for injuries to persons or damage to property that may arise from or in connection with the use of the Premises.
9. Indemnification/Hold Harmless. Pierce Transit will defend, indemnify and hold harmless the Owner, its officers, officials, employees, and volunteers from and against any and all claims, suits, actions or liabilities for injury or death of any person, or for loss or damage to property, which arises out of the use of Premises or from any activity, work or things done, permitted or suffered by Pierce Transit in or about the Premises, except only such injury or damage as shall have been occasioned by the sole negligence of Owner.
10. Governmental Charges. Pierce Transit shall not be responsible for any taxes, assessments, or governmental charges of any kind that may be levied against the Premises.
11. Termination. Pierce Transit will discontinue its use of the Premises on termination of this Agreement; will remove all signs and structures placed on the Premises by Pierce Transit; will repair any damage to the Premises caused by the removal; and will restore the Premises to as good a condition, less reasonable wear and tear, as existed prior to the execution of this Agreement.
12. Accommodation. The parties agree to make reasonable accommodations with and to work together to resolve problems that may arise from time to time. Upon reasonable advance notice to Pierce Transit and its users, the Owner may secure the Premises on a limited number of dates to allow for construction on surrounding property or special events. The Owner agrees to provide special consideration for vehicles displaying a government-issued “handicapped” license plate or decal.
13. Entire Agreement. This document contains the entire agreement between the parties and supersedes all other statements or understandings between the parties.



APPENDIX E. FIELD TEST LOCATIONS

The Bus Stop Checklist was tested in the field with the following transit agencies:

- **AC Transit in Oakland, California**
Robert Del Rosario
Transportation Planner
AC Transit
1600 Franklin Street
Oakland, California 94612
- **Fairfax County Department of Transportation in Fairfax, Virginia**
Denis P. Paddeu
Senior Transportation Specialist
Fairfax County Department of Transportation/Fairfax Connector
12055 Government Center Parkway, Suite 1034
Fairfax, Virginia 22035-5515
- **Marin County Transit District in Marin, California**
Amy Van Doren
Transit Manager
Marin County Transit District
Marin County Civic Center
Room 304
San Rafael, California 94913-4186
- **Niagara Frontier Transportation Authority in Buffalo, New York**
Christopher Cronin
Traffic Data Administrator
Niagara Frontier Transportation Authority
181 Ellicott Street
Buffalo, New York 1420

- **Southeast Transportation Authority in Greenwood Village, Colorado**
Suzanne O’Neill
Transportation Manager
30 South Raritan Street
Denver, Colorado 80223
- **SunLine Transit Agency in Palm Springs**
Eunice Lovi
Director of Planning
SunLine Transit Agency
32-505 Harry Oliver Trail
Thousand Palms, California 92276

APPENDIX F. USEFUL RESOURCES

- ADA Accessibility Guidelines for Buildings and Facilities (ADAAG): <http://www.access-board.gov/adaag/html/adaag.htm>
- Center for People with Disabilities: To determine the accessibility barriers to using bus stops in the City of Boulder for people with disabilities, consumer volunteers researched the reported problems and documented the barriers they found. The barriers found may be applicable to transit systems throughout the U.S. The findings are detailed on their website: <http://www.cpwd-ilc.org/cpwd/ilp/survey05/>.
- Universal Design: IDEA Center, State University of New York at Buffalo; Global Universal Design Educator's Network, <http://www.udeducation.org/>. This site supports educators and students in their teaching and study of universal design. Provides information on universal design and links to resources.

Toolkit



for the assessment of Bus Stop Accessibility and Safety





Table of Contents

Introduction	1
Contact Information.....	2
Project Advisory Committee and Team	3
Members of the Committee:	3
Myths of Bus Stop Accessibility	5
Principles of Bus Stop Design.....	7
Barrier-Free Design	7
Urban Wayfinding	7
Safety and Warning	8
How to Conduct a Bus Stop Inventory	9
Sample Bus Stop Checklist	10
Creating Accessible and Safe Bus Stops.....	13
Distinction Between ADA Requirements and Universal Design	13
Design Guidelines.....	14
Bus Stop Area and Bus Landing Pads	14
Bus Shelter Design	19
Lighting.....	23
Security.....	24
Accessible Path	25
Route and Timetable Information.....	29
Transit Signage.....	30
Amenities.....	33
Identifying a Bus Stop by People with Visual Impairments.....	38
Maintenance of Bus Stops and Shelters	39
Key Players and Agency Coordination.....	41
Interdepartmental Collaboration.....	42
Driver Training and Support	43
Reducing Bus Operator Tasks.....	43
Cooperation Between Drivers and Bus Stop Planners	44

Technology and Product Links	45
Talking Signs® Technology	45
Automated Docking Systems.....	45
NextBus	47
i-Stops.....	49
Bus Stop Shelter Product Links	49
Urban and Rural Bus Stops.....	51
Population with Disabilities in Urban and Rural Areas	51
Rural Bus Stops.....	52
Appendix A. Quick Bus Stop Checklist.....	A-1
Appendix B. Tri-Met Maintenance Guidelines.....	B-1
Appendix C. Case Studies/Examples of Agency Coordination	C-1
Appendix D. Sample Agreement for Private Road Bus Stop Placement	D-1
Appendix E. Field Test Locations	E-1
Appendix F. Useful Resources.....	F-1

Table of Figures

Figure 1. Acceptable Color Combinations Based on Contrast	54
Figure 2. NextBus Information Flow.....	69
Figure 3. Bus Information Display	70
Figure 4. Disability Demographics in Urban and Rural America.....	74

INTRODUCTION

Bus stops are a key link in the journey of a bus rider. For people with disabilities, inaccessible bus stops often represent the weak link in the system and can effectively prevent the use of fixed-route bus service. Physical, cognitive, and psychological barriers associated with bus stops can severely hamper bus ridership by the disability community, thus limiting their mobility and potentially leading to increased paratransit costs.

This toolkit is primarily targeted towards staff at transit agencies and public works departments who are responsible for bus stop design and placement. The toolkit is intended to be a convenient resource that can be used to enhance the accessibility of specific bus stops, or help in the development of a strategic plan to achieve system-wide accessibility. Disability community representatives should also find in these pages material that can be used to advocate for accessibility improvements and barrier removal.

We encourage you to selectively draw on the sections that are most relevant to your situation. Your feedback on the toolkit will be most appreciated, and can be submitted either via a telephone call to Easter Seals Project ACTION, or via a short survey. Please let us know if there are critical topics that should be included in future versions of the toolkit.



Use the Toolkit to:

- Determine minimum ADA requirements
- Enhance bus stop accessibility through universal design
- Inventory bus stops
- Develop a strategic plan for system-wide accessibility
- Advocate for improvements



CONTACT INFORMATION

The Toolkit for Bus Stop Accessibility and Safety Assessment is provided by Easter Seals Project ACTION (Accessible Community Transportation In Our Nation). Funded through a cooperative agreement with the U.S. Department of Transportation, Federal Transit Administration, Project ACTION promotes cooperation between the transportation industry and the disability community to increase mobility for people with disabilities under the ADA and beyond.

For information, questions or assistance, please contact:

Easter Seals Project ACTION

Address: 700 13th Street NW, Suite 200, Washington, DC 20005

Phone: 202.347.3066 or 800.659.6428

Fax: 202.737.7914

TDD: 202.347.7385

Email: projectaction@easterseals.com

Web Address: www.projectaction.org

PROJECT ADVISORY COMMITTEE AND TEAM

The Toolkit was developed by Nelson\Nygaard Consulting Associates with the aid of the Project ACTION Advisory Committee and Team. Committee and Team members represented the diverse interests of transit agencies, people with disabilities, and various local, state and federal agencies.

Members of the Committee:

- Billy Altom, Delta Resource Center for Independent Living, Project ACTION National Steering Committee, Pine Bluff, Arkansas
- Alexandra Enders, Center on Disability in Rural Communities, University of Montana, Missoula, Montana
- Dennis Cannon, U.S. Access Board, Washington, DC
- Julie Kirschbaum, San Francisco County Transportation Authority, San Francisco, California
- Kevin Irvine, Equip for Equality, Inc., Chicago, Illinois
- Marilyn Golden, Disability Rights Education and Defense Fund, Berkeley, California
- Robert Del Rosario, AC Transit, Oakland, California
- Tim Renfro, Pierce Transit, Lakewood, Washington

Nelson\Nygaard was assisted by significant contributions from the following team members:

- Access Compliance Services, Santa Cruz, California
- Center of Inclusive Design and Environmental Access, School of Architecture and Planning, University at Buffalo, Buffalo, New York
- June Kailes, Disability Policy Consultant, Playa Del Rey, California
- Robert Perrone Consulting, Palm Springs, California
- Smith-Kettlewell Eye Research Institute, San Francisco, California



MYTHS OF BUS STOP ACCESSIBILITY

Myth 1: Only a small percentage of the transit ridership will benefit from bus stop accessibility improvements.

- Accessibility improvements for people with disabilities enhance the usability of transit systems for all riders. For example, paving a grassy surface to serve as a bus stop landing pad provides a stable surface for waiting patrons; adequate lighting alleviates the security issues of using the bus after dark; and good information reduces ambiguity of the system. Accessibility improvements should be viewed within the context of general system usability, not as “those things you do for those other people.”
- Accessibility improvements also benefit people with a range of disabilities, from physical conditions affecting mobility, stamina, sight, hearing and speech to other conditions, such as emotional illness and learning disorders. Such disabilities may or may not be evident to others. The percentage of the U.S. population affected by a condition that constitutes a disability under the Americans with Disabilities Act (ADA) is expected to increase over the coming decades, in part due to the growing elderly population. Additionally, transit users carrying packages or luggage, pushing children in strollers, or otherwise transporting items will also benefit from accessibility improvements.¹

Myth 2: Bus stop accessibility and safety improvements are not our responsibility.

- As bus stops are located on the public right-of-way or on private property, transit agencies may not have jurisdiction to implement improvements. Though this may be the case, it is in the interest of the transit agency to work with its municipality, community and businesses on bus stop improvements. Bus stops advertise an image of the transit service and agency. Poorly maintained, unsafe, uninformative and inaccessible stops convey a poor image of the agency and discourage use.
- Rising paratransit costs are another reason bus stop safety and accessibility improvements should be the responsibility of the transit agency. Providing an unobstructed landing pad, wayfinding signs, clear transit information at the eye level of a wheelchair user and other basic improvements can encourage some paratransit users to use fixed route transit, decreasing the agency's paratransit costs.
- Lastly, several transit agencies have been sued and lost cases due to the inaccessibility of their bus stops. Transit agencies are required to provide accessible transit, and accessible bus stops are an integral part of an accessible system. Similarly, public works departments are required to construct accessible facilities and ensure program accessibility of existing facilities.



¹ Public Rights-of-Way Access Advisory Committee, *Building a True Community* U.S. Access Board 2001.



Myth 3: Once we have implemented bus stop accessibility improvements, the stop will always be accessible.

- Though accessibility and safety improvements have been implemented, the stop may not meet standards indefinitely. Many factors may decrease accessibility and safety, including construction, unregulated placement of newspaper vending machines and poor maintenance. Stops should be regularly monitored to ensure that the stop is clear of obstructions.

Myth 4: To change flag stops to fixed bus stops, each new stop must have a landing pad.

- New bus stops should be accessible to all patrons. Agencies are not required, however, to install landing pads at all stops. Where landing pads are provided, they must comply with the requirements stated in the section on Bus Stop Area and Bus Landing Pads. It is recommended that fixed bus stops be located where there is a stable, level, raised and slip-resistant surface to facilitate boarding and alighting for all passengers. If this type of surface is not available at the location chosen for the bus stop, a landing pad should be installed. If patrons who use wheelchairs are not able to use the stop, the transit agency would fail to meet the overarching mandate of Title II of the ADA to provide accessible transportation.

Myth 5: We can prohibit patrons with wheelchairs from boarding and alighting at stops that are not currently accessible.

- A transit agency may not legally prohibit the boarding and alighting of passengers with wheelchairs, unless the lift or ramp would be damaged if deployed, or if temporary conditions at the stop prevent any disembarkation. If the bus stop is located in an area where conditions would damage the lift, such as a steep slope, it is recommended that the driver stop at a nearby location that has a stable surface.²

² ADA DOT Regulation Sec. 37.167(g): Other service requirements, http://www.fta.dot.gov/legal/regulations/us_dot/5601_5606_ENG_HTML.htm

PRINCIPLES OF BUS STOP DESIGN³

For a bus stop to be accessible, three elements should be incorporated into the siting and design of the stop. These elements are:

1. Barrier-Free Design
2. Urban Wayfinding
3. Safety and Warning

Barrier-Free Design

Barrier-Free Design entails designing a bus stop and path so that a person with a disability can proceed unimpeded to the sidewalk or an accessible building served by the transit stop. The basic principles of Barrier-Free Design include:

- Planning outdoor elements to minimize obstacles and eliminate travel hazards such as support cables for utility poles and low signage protruding into the travel path.
- Positioning newspaper boxes and other street furniture close to the edge of a travel path, out of the main flow of pedestrian traffic and the bus landing pad.
- Avoiding grade-level changes in sidewalk and platforms wherever possible.
- Providing slip-resistant finishes, good grip and sure footing to ensure surfaces are safe.
- Supplying seating adjacent to pathway routes.

Urban Wayfinding

Wayfinding is the process of movement from one predetermined destination to another, and is an activity that demands complete involvement with the environment. The basic principles of orientation and wayfinding are:

- Providing consistency and uniformity of elements and layout
- Simplifying orientation by using right angles for design elements and layout



The use of paving stones creates a park-like feel and makes this bus stop in Palm Springs, California tactually and visually distinct from the adjacent concrete sidewalk.

Source: Robert Perrone Consulting

³ Province of Alberta, Transportation & Utilities, *Design Guidelines for Accessible Pedestrian Environments* 1996.



- Providing tactile as well as visual cues and landmarks within designs (examples: sidewalks with grass shoulders or borders; street furnishings such as benches; garbage receptacles; planters located adjacent to but not within path of travel; high contrasts on shelter door frames)
- Illuminating walkways, hazards and waiting areas for orientation and security purposes
- Providing logical, unbroken travel paths from sidewalk to bus boarding platform
- Using color contrast, sound, light and shade to accentuate travel paths between shelter, sidewalk and bus boarding platform

Safety and Warning

As with all aspects of roadway design and bus operations, an important element in the design of bus stops is safety and warning.

The basic principles of safety and warning are:

- Providing a bus stop with good ergonomics and effective wayfinding will also be beneficial for safety and warning purposes
- Placing street furniture such as benches, newspaper vending boxes, and planters to create barriers from hazards
- Ensuring good lighting and visibility from surrounding land uses
- Highlighting the existence of hazards by distinctive markings, signs and higher light levels where inadvertent exposure to hazards cannot be blocked

HOW TO CONDUCT A BUS STOP INVENTORY

Inventorying conditions at and around bus stops is the first step in determining and implementing improvements. The data can also be used to communicate the bus stop location, coordinates, surrounding land uses and its condition for patrons with disabilities to inform them of the stop’s travel path and accessibility. Additionally, a database of existing conditions provides the opportunity to comply with ADA regulations, coordinate with other agencies and consider real time information.

For information on how to conduct and maintain a bus stop inventory, refer to *Bus Stop Inventory: Best Practices and Recommended Procedures*, from the Bus Stop Inventory Task Force of the Transit Standards Consortium, Incorporated. The Transit Standards Consortium is comprised of transit industry stakeholders and conducts research, testing, training and maintenance of transit standards to improve transit’s quality of service. The Bus Stop Inventory manual is a useful resource in developing and utilizing a valuable inventory.

The manual can be purchased from the website, <http://www.tsconsortium.org>. The table of contents of the report is reproduced below.



Chapter	Content
1	Introduction
2	Planning a Bus Stop Inventory
3	Components of a Bus Stop Inventory
4	Field Collection
5	Integration and Maintenance
6	Summary and Conclusion
Appendix One	Acronyms, Definitions
Appendix Two	Core Elements, Associated Elements, Related Subsystem Elements
Appendix Three	Design and Development of a Bus Stop Inventory to Support an Intelligent Transportation System: The MARTA Experience
Appendix Four	Creating a Bus Stop Inventory and Transit Scheduling Database for Metro
Appendix Five	Dallas Bus Stop Database Design
Appendix Six	Statement of Work Sample
Appendix Seven	Case Studies



Transit agency official measures the distance between the edge of the shelter and the curb, using a measuring wheel, to determine if enough clearance is available for wheelchair users to board and alight the bus.

Source: NelsonNygaard Consulting Associates

Sample Bus Stop Checklist

The Sample Bus Stop Checklist is based on a model utilized by Arlington County in Virginia, and modified to incorporate items and ideas from other checklists and feedback from a series of field tests.⁴ Toolkit users are encouraged to customize the checklist according to the needs of their transit services, by changing lines directly in the tool. The Sample Bus Stop Checklist is intended for use by transit and public works agencies. A Quick Bus Stop Checklist is available for advocates and the general public.

Though the checklist may be completed at any time of day, certain sections, such as the Lighting Assessment, are best performed in the evening or night-time to effectively determine the safety, security and accessibility of the stop.

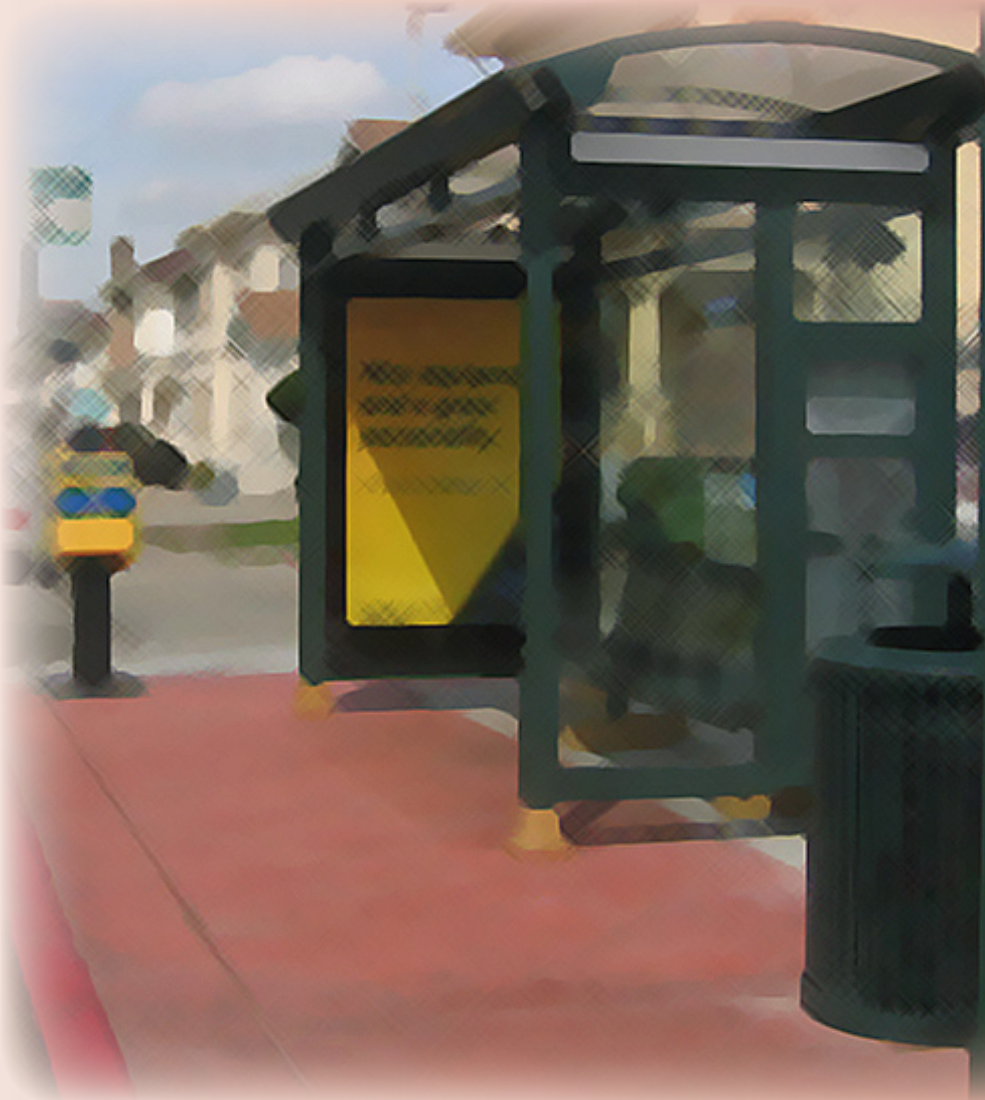
The equipment needed to acquire data for the site is listed below, divided into “basic” and “additional.” These categories are based on the type of information the transit agency is collecting, the use of paper forms or computer and the level of accuracy desired.

- **Basic:**
 - ✘ Database
 - ✘ Checklist
 - ✘ Clipboard
 - ✘ Camera (preferably digital to be able to download to a database)
 - ✘ Measuring wheel
- **Additional**
 - ✘ Handheld device or laptop onto which the checklist can be downloaded
 - ✘ Global Positioning System (GPS) to calculate the location of the bus stop
 - ✘ Vehicle with GPS outfitted with computer equipment and sensors to transport the crew to the bus stop locations and gather data

⁴ Refer to Appendix E for a list of locations where the Checklist was tested.

After conducting the bus stop inventory:

- If the checklist was completed using paper forms, the information gathered should be entered into a database. An Excel spreadsheet or Access database are the most convenient ways to store the information.
- Once a database is created, the data may be used to prioritize improvements according to the condition of the stop or shelter, the use of the stop by persons with disabilities, ridership, and/or the importance of the connections provided by the bus stop location. The database should be updated to include the current conditions at the stop.



BUS STOP CHECKLIST

PART A: IDENTIFICATION/LOCATION

<i>Route Name:</i>	<i>Location:</i>	<i>Weather Conditions:</i>	<i>Stop No.:</i>
--------------------	------------------	----------------------------	------------------

PART A: IDENTIFICATION/LOCATION		Yes	No	N/A
A1	Is there a bus shelter?	<input type="checkbox"/>	<input type="checkbox"/>	<input type="checkbox"/>
	<i>If YES, what is the number of the shelter?</i>			
	<i>If NO, is there an exterior alternative shelter nearby (i.e. - awning, overhangs, underpass)?</i>	<input type="checkbox"/>	<input type="checkbox"/>	<input type="checkbox"/>
A2	Street Name:			
A3	Nearest Cross Street (street name or landmark if mid-block):			
A4	Bus Route Direction:			
	North Bound <input type="checkbox"/>	South Bound <input type="checkbox"/>	More than one direction <input type="checkbox"/>	
	East Bound <input type="checkbox"/>	West Bound <input type="checkbox"/>		
A5	What is the purpose of the stop?			
	Park and Ride <input type="checkbox"/>	Boarding <input type="checkbox"/>	Both Boarding and Alighting <input type="checkbox"/>	Other (specify): <input type="checkbox"/>
	Kiss and Ride <input type="checkbox"/>	Alighting <input type="checkbox"/>	Transfer <input type="checkbox"/>	
A6	What is the average number of daily boardings at the stop?			
A7	Where is the bus stop positioned in relation to the nearest intersection?			
	Nearside (Before the bus crosses the intersection)	<input type="checkbox"/>		
	Far Side (After the bus crosses the intersection)	<input type="checkbox"/>		
	Mid-block	<input type="checkbox"/>		
	Not near an intersection	<input type="checkbox"/>		
	Freeway bus pad	<input type="checkbox"/>		
	N/A	<input type="checkbox"/>		

<i>Date</i>	<i>Time:</i>	<i>Surveyor:</i>
-------------	--------------	------------------

BUS STOP CHECKLIST

PART A: IDENTIFICATION/LOCATION

<i>Route Name:</i>	<i>Location:</i>	<i>Weather Conditions:</i>	<i>Stop No.:</i>
--------------------	------------------	----------------------------	------------------

A8	Distance from bus stop pole to curb of cross street in feet:			
A9	Adjacent property address or name of business (only if readily visible):			
A10	Adjacent Property Description:			
	Apartment Building <input type="checkbox"/>	Industrial Site/Bldg. <input type="checkbox"/>	Park <input type="checkbox"/>	School <input type="checkbox"/>
	Day Care <input type="checkbox"/>	Library <input type="checkbox"/>	Park and Ride <input type="checkbox"/>	Supermarket <input type="checkbox"/>
	Government Building <input type="checkbox"/>	Mall/Shopping Center <input type="checkbox"/>	Place of Worship <input type="checkbox"/>	Transit station/center <input type="checkbox"/>
	Hospital <input type="checkbox"/>	Nursing Home <input type="checkbox"/>	Residence – townhouse <input type="checkbox"/>	Vacant lot <input type="checkbox"/>
	Human Service Agency <input type="checkbox"/>	Office Building <input type="checkbox"/>	Residence – detached <input type="checkbox"/>	Other (specify): <input type="checkbox"/>
		Retail Store <input type="checkbox"/>		
A11	Distance from previous bus stop (in feet):			

<i>Date</i>	<i>Time:</i>	<i>Surveyor:</i>
-------------	--------------	------------------

BUS STOP CHECKLIST

PART B: PEDESTRIAN ACCESS FEATURES

<i>Route Name:</i>	<i>Location:</i>	<i>Weather Conditions:</i>	<i>Stop No.:</i>
--------------------	------------------	----------------------------	------------------

PART B: PEDESTRIAN ACCESS FEATURES

Section B-1: Landing Area Assessment

B1	Is there a landing area at least 5 feet wide and 8 feet deep adjacent to the curb/street?			Yes <input type="checkbox"/>	No <input type="checkbox"/>	
B2	Where is the landing area positioned in relation to the curb/street?					
	Below street level (low ground or shoulder) <input type="checkbox"/>	Shoulder <input type="checkbox"/>	Other (specify): <input type="checkbox"/>			
	Sidewalk <input type="checkbox"/>	Adjacent <input type="checkbox"/>	Bus Bulb <input type="checkbox"/>	Off-Road/No sidewalk <input type="checkbox"/>		
B3	What is the material of the landing area?					
	Asphalt <input type="checkbox"/>	Dirt <input type="checkbox"/>	Gravel <input type="checkbox"/>	Other (specify): <input type="checkbox"/>		
	Concrete <input type="checkbox"/>	Grass <input type="checkbox"/>	Pavers <input type="checkbox"/>			
B4	Are there problems with the landing area surface?				Yes <input type="checkbox"/>	No <input type="checkbox"/>
	<i>If YES, rank resulting accessibility potential:</i>					
		Not Accessible	Minimally Accessible	Accessible		
	Uneven	<input type="checkbox"/>	<input type="checkbox"/>	<input type="checkbox"/>		
	Slopes up from the street	<input type="checkbox"/>	<input type="checkbox"/>	<input type="checkbox"/>		
	Slopes down from the street	<input type="checkbox"/>	<input type="checkbox"/>	<input type="checkbox"/>		
	Requires stepping over drain inlet	<input type="checkbox"/>	<input type="checkbox"/>	<input type="checkbox"/>		
Other (Specify)	<input type="checkbox"/>	<input type="checkbox"/>	<input type="checkbox"/>			
B5	Are there any obstacles that would limit the mobility of a wheelchair?				Yes <input type="checkbox"/>	No <input type="checkbox"/>
	<i>If YES, describe obstruction:</i>					

<i>Date</i>	<i>Time:</i>	<i>Surveyor:</i>
-------------	--------------	------------------

BUS STOP CHECKLIST

PART B: PEDESTRIAN ACCESS FEATURES

<i>Route Name:</i>	<i>Location:</i>	<i>Weather Conditions:</i>	<i>Stop No.:</i>
--------------------	------------------	----------------------------	------------------

B6	Additional landing area comments:		
B7	Landing area recommendations:		
	Widen sidewalk to expand landing area to 5 feet wide and 8 feet deep		<input type="checkbox"/>
	Install curb bulb or remove on street parking		<input type="checkbox"/>
	Move object to improve accessibility (specify where):		
	Make the following repairs (specify):		
Other (specify):			

Section B-2: Connections (Trip Generators)

B8	What are the primary trip generators for passengers at this stop? (Check all that apply)		
Apartment - large building/complex	<input type="checkbox"/>	Human service agency – what kind?	<input type="checkbox"/>
Apartment - small building	<input type="checkbox"/>	Library	<input type="checkbox"/>
Townhomes	<input type="checkbox"/>	Major Shopping/employment (Mall, Wal-Mart, Kmart, Target, other big department store)	<input type="checkbox"/>
Detached homes	<input type="checkbox"/>	Neighborhood Shopping (supermarket, drugstore, Goodwill, strip mall with basic needs shopping)	<input type="checkbox"/>
Day care/pre-school	<input type="checkbox"/>	Nursing home/assisted living	<input type="checkbox"/>
Gas station	<input type="checkbox"/>	Office building/employment	<input type="checkbox"/>
Government building	<input type="checkbox"/>	Park and Ride lot	<input type="checkbox"/>
Hospital/major clinic	<input type="checkbox"/>	Place of worship	<input type="checkbox"/>
Hotel	<input type="checkbox"/>	Restaurant	<input type="checkbox"/>
			School –Elementary/Middle <input type="checkbox"/>
			School -High <input type="checkbox"/>
			School - College/University/ Technical school <input type="checkbox"/>
			Senior center <input type="checkbox"/>
			Transfer to other bus routes <input type="checkbox"/>
			Transit station/center <input type="checkbox"/>
			Other (Specify): <input type="checkbox"/>

<i>Date</i>	<i>Time:</i>	<i>Surveyor:</i>
-------------	--------------	------------------

BUS STOP CHECKLIST

PART B: PEDESTRIAN ACCESS FEATURES

<i>Route Name:</i>	<i>Location:</i>	<i>Weather Conditions:</i>	<i>Stop No.:</i>
--------------------	------------------	----------------------------	------------------

B9	How wide is the sidewalk?			
	No sidewalk <input type="checkbox"/>	less than 3' <input type="checkbox"/>	3'-5' <input type="checkbox"/>	5' or greater <input type="checkbox"/>
B10	Are there physical barriers that constrict the width of the sidewalk within the block on which the bus stop is located?			Yes No <input type="checkbox"/> <input type="checkbox"/>
	<i>If YES, what is the narrowest useable width:</i>			
	Less than 3' <input type="checkbox"/>		3' or greater <input type="checkbox"/>	
B11	Rank the condition of the sidewalk:			
	1 <input type="checkbox"/>	2 <input type="checkbox"/>	3 <input type="checkbox"/>	4 <input type="checkbox"/>
<i>1=hazardous – large breaks, cracks, root uplifting, someone could get hurt from normal use or use of a wheelchair would be difficult</i> <i>2=in poor shape though not hazardous – very rough, some root uplifting, cracks, breaks</i> <i>3=fair – minor root uplifting, minor cracks or breaks</i> <i>4=good – not perfect but no immediate repair</i> <i>5=cosmetically excellent; new</i>				
B12	Does the landing pad connect to the sidewalk?			Yes No <input type="checkbox"/> <input type="checkbox"/>
	<i>If YES, what does the sidewalk connect to:</i>			
	One of the trip generators listed in Question B8 <input type="checkbox"/>		The nearest intersection <input type="checkbox"/>	
B13	Where is the nearest street crossing opportunity?			
	The nearest intersection <input type="checkbox"/>		Mid-block crosswalk <input type="checkbox"/>	
B14	What pedestrian amenities are at the nearest intersection (or other crossing opportunity)?			
	Curb cuts all corners/ both sides <input type="checkbox"/>	Pedestrian crossing signal <input type="checkbox"/>	Traffic Light <input type="checkbox"/>	
	Visible crosswalk <input type="checkbox"/>	Audible crosswalk signal <input type="checkbox"/>	Crossing guard assistance <input type="checkbox"/>	
	Curb cuts at some corners/one side <input type="checkbox"/>	Accessible Pedestrian Signal (APS) <input type="checkbox"/>	Tactile warning strip on curb cut <input type="checkbox"/>	
		Other (specify): <input type="checkbox"/>		

<i>Date</i>	<i>Time:</i>	<i>Surveyor:</i>
-------------	--------------	------------------

BUS STOP CHECKLIST

PART B: PEDESTRIAN ACCESS FEATURES

<i>Route Name:</i>	<i>Location:</i>	<i>Weather Conditions:</i>	<i>Stop No.:</i>
--------------------	------------------	----------------------------	------------------

B15	Is there a companion bus stop across the street?	Yes No N/A <input type="checkbox"/> <input type="checkbox"/> <input type="checkbox"/>
	B16	Are there connections to other transportation services at this bus stop? <i>If YES, check all that apply</i>
	Bus services, same or other agency <input type="checkbox"/>	Local Rail <input type="checkbox"/>
	Greyhound <input type="checkbox"/>	Commuter Rail <input type="checkbox"/>
	Other (Specify): <input type="checkbox"/>	
B17	Pedestrian connection recommendations:	
	Construct sidewalk	<input type="checkbox"/>
	Widen sidewalk	<input type="checkbox"/>
	Improve landing area connections to sidewalk	<input type="checkbox"/>
	Install curb cut(s) at:	
	Move object to improve accessibility (specify where):	
	Make the following repairs (specify):	
Other (specify):		
B18	Additional pedestrian connection comments:	

<i>Date</i>	<i>Time:</i>	<i>Surveyor:</i>
-------------	--------------	------------------

BUS STOP CHECKLIST

PART C: PASSENGER COMFORT AMENITIES

<i>Route Name:</i>	<i>Location:</i>	<i>Weather Conditions:</i>	<i>Stop No.:</i>
--------------------	------------------	----------------------------	------------------

PART C: PEDESTRIAN COMFORT AMENITIES

Section C-1: Shelters (move to Section C-2 if there is no shelter)

C1	What is the orientation of the bus shelter in relation to the street?										
	Facing towards the street					<input type="checkbox"/>					
	Facing on-coming traffic					<input type="checkbox"/>					
	Facing away from the street					<input type="checkbox"/>					
C2	What kind of shelter is it? Insert shelter relevant to your system.										
	Own transit agency	<input type="checkbox"/>	Another transit agency (shared stop)	<input type="checkbox"/>	Other (Specify): <input type="checkbox"/>						
C3	If non-standard shelter, what are the approximate dimensions (width, height and depth in feet) of the interior standing area?										
	Width:										
	Height:										
	Depth:										
C4	Does the shelter have a front center panel (i.e. two openings)?					Yes No <input type="checkbox"/> <input type="checkbox"/>					
	<i>If YES, what are the dimensions of the opening?</i>										
C5	Could a person using a wheelchair maneuver into the shelter?					Yes No <input type="checkbox"/> <input type="checkbox"/>					
C6	Could a person using a wheelchair fit completely under the shelter (minimum space of a common mobility device is 30 in. by 48 in. (760 mm by 1200mm))?					Yes No <input type="checkbox"/> <input type="checkbox"/>					
	What are the dimensions of the clear space in the shelter?										
C7	What is the distance of the front of the shelter from the curb in feet?										
	0 - 2'	<input type="checkbox"/>	2' - 4'	<input type="checkbox"/>	4' - 6'	<input type="checkbox"/>	6' - 8'	<input type="checkbox"/>	8' - 10'	<input type="checkbox"/>	>10'

<i>Date</i>	<i>Time:</i>	<i>Surveyor:</i>
-------------	--------------	------------------

BUS STOP CHECKLIST

PART C: PASSENGER COMFORT AMENITIES

<i>Route Name:</i>	<i>Location:</i>	<i>Weather Conditions:</i>	<i>Stop No.:</i>
--------------------	------------------	----------------------------	------------------

C8	Are there damages to the bus shelter?				Yes	No				
					<input type="checkbox"/>	<input type="checkbox"/>				
	<i>If YES, check all that apply:</i>									
	Broken panels				<input type="checkbox"/>					
	Graffiti				<input type="checkbox"/>					
	Holes in the roof				<input type="checkbox"/>					
	Missing panels				<input type="checkbox"/>					
Needs repainting				<input type="checkbox"/>						
Other (specify):				<input type="checkbox"/>						
C9	What is the approximate age of the shelter?									
C10	Rank the condition of the shelter:									
	1	<input type="checkbox"/>	2	<input type="checkbox"/>	3	<input type="checkbox"/>	4	<input type="checkbox"/>	5	<input type="checkbox"/>
<i>1=hazardous – broken glass, unstable</i> <i>2=in poor shape though not hazardous</i> <i>3=fair – needs repainting, glass panels need thorough cleaning, protruding but not hazardous bolts</i> <i>4=good – not perfect but no immediate repair need</i> <i>5=cosmetically excellent; new</i>										
C11	Additional shelter comments:									

<i>Date</i>	<i>Time:</i>	<i>Surveyor:</i>
-------------	--------------	------------------

BUS STOP CHECKLIST

PART C: PASSENGER COMFORT AMENITIES

<i>Route Name:</i>	<i>Location:</i>	<i>Weather Conditions:</i>	<i>Stop No.:</i>
--------------------	------------------	----------------------------	------------------

C12	Shelter recommendations:		
	Remove center panel		<input type="checkbox"/>
	Make the following repairs (specify):		<input type="checkbox"/>
	Move object to improve accessibility (specify where):		
	Move shelter to improve accessibility (specify where):		
	Other (specify):		

Section C-2: Seating Assessment (move to Section C-3 if there is no seating)

C13	What is the type of seating available?						
	Bench inside shelter – skip to question C15						<input type="checkbox"/>
	Freestanding bench						<input type="checkbox"/>
	Fold down bench						<input type="checkbox"/>
	Leaning bench						<input type="checkbox"/>
	Other (specify):						<input type="checkbox"/>
C14	If not inside shelter, what is the distance of the seating from the curb in feet?						
	0 - 2' <input type="checkbox"/>	2' - 4' <input type="checkbox"/>	4' - 6' <input type="checkbox"/>	6' - 8' <input type="checkbox"/>	8' - 10' <input type="checkbox"/>	>10' <input type="checkbox"/>	
C15	Are there problems with the seating?						Yes No <input type="checkbox"/> <input type="checkbox"/>
	<i>If YES, check all that apply:</i>						
	Broken pieces						<input type="checkbox"/>
	Needs painting						<input type="checkbox"/>
	Graffiti						<input type="checkbox"/>
	Not securely installed						<input type="checkbox"/>
	Other (specify):						<input type="checkbox"/>

<i>Date</i>	<i>Time:</i>	<i>Surveyor:</i>
-------------	--------------	------------------

BUS STOP CHECKLIST

PART C: PASSENGER COMFORT AMENITIES

<i>Route Name:</i>	<i>Location:</i>	<i>Weather Conditions:</i>	<i>Stop No.:</i>
--------------------	------------------	----------------------------	------------------

C16	Rank the condition of the seating:									
	<table border="1"> <tr> <td>1</td> <td><input type="checkbox"/></td> <td>2</td> <td><input type="checkbox"/></td> <td>3</td> <td><input type="checkbox"/></td> <td>4</td> <td><input type="checkbox"/></td> <td>5</td> <td><input type="checkbox"/></td> </tr> </table> <p> <i>1=hazardous – broken, someone could get hurt from normal use</i> <i>2=in poor shape though not hazardous</i> <i>3=fair – needs repainting, needs cosmetic attention,, protruding but not hazardous bolts</i> <i>4=good – not perfect but no immediate repair need</i> <i>5=cosmetically excellent; new</i> </p>	1	<input type="checkbox"/>	2	<input type="checkbox"/>	3	<input type="checkbox"/>	4	<input type="checkbox"/>	5
1	<input type="checkbox"/>	2	<input type="checkbox"/>	3	<input type="checkbox"/>	4	<input type="checkbox"/>	5	<input type="checkbox"/>	
C17	Additional seating comments:									
C18	Seating recommendations:									
	Move seating to improve accessibility (specify where):									
	Make the following repairs (specify):									
	Other (specify):									

<i>Date</i>	<i>Time:</i>	<i>Surveyor:</i>
-------------	--------------	------------------

BUS STOP CHECKLIST

PART C: PASSENGER COMFORT AMENITIES

<i>Route Name:</i>	<i>Location:</i>	<i>Weather Conditions:</i>	<i>Stop No.:</i>
--------------------	------------------	----------------------------	------------------

Section C-3: Trash Assessment (move to Section C-4 if there is no trash receptacle)	
C19	What is the type of installation for the trash receptacle?
	Attached to the shelter <input type="checkbox"/>
	Free standing <input type="checkbox"/>
	Garbage bag <input type="checkbox"/>
	Bolted to sidewalk <input type="checkbox"/>
Other (specify): <input type="checkbox"/>	
C20	Are there problems with the trash receptacle and surrounding area? Yes No
	<input type="checkbox"/> <input type="checkbox"/>
	<i>If YES, check all that apply:</i>
	Trash can very full <input type="checkbox"/>
	Graffiti at bus stop <input type="checkbox"/>
	Bus stop littered <input type="checkbox"/>
	Grocery carts left at stop <input type="checkbox"/>
	Trash can not securely installed <input type="checkbox"/>
Adjacent property littered <input type="checkbox"/>	
Other (specify): <input type="checkbox"/>	
C21	Additional Comments:
C22	Trash recommendations:
	Install trash can due to litter problem <input type="checkbox"/>
	Make the following repairs (specify):
	Move trash can to improve accessibility (specify where):
Other (specify):	

<i>Date</i>	<i>Time:</i>	<i>Surveyor:</i>
-------------	--------------	------------------

BUS STOP CHECKLIST

PART C: PASSENGER COMFORT AMENITIES

<i>Route Name:</i>	<i>Location:</i>	<i>Weather Conditions:</i>	<i>Stop No.:</i>
--------------------	------------------	----------------------------	------------------

Section C-4: Newspaper Boxes (move to Part D if there are no newspaper boxes)		
C23	Are the newspaper boxes a barrier to sidewalk use?	Yes No <input type="checkbox"/> <input type="checkbox"/>
C24	Are the newspaper boxes a barrier to bus access/egress?	Yes No <input type="checkbox"/> <input type="checkbox"/>
C25	Are they chained to the bus stop pole, shelter, or bench?	Yes No <input type="checkbox"/> <input type="checkbox"/>
C26	Are they blocking access to posted bus schedule info?	Yes No <input type="checkbox"/> <input type="checkbox"/>
C27	Additional newspaper box comments:	
C28	Newspaper box recommendations:	
	Move trash can to improve accessibility (specify where):	
	Other (specify):	

<i>Date</i>	<i>Time:</i>	<i>Surveyor:</i>
-------------	--------------	------------------

BUS STOP CHECKLIST

PART D: SAFETY AND SECURITY FEATURES

<i>Route Name:</i>	<i>Location:</i>	<i>Weather Conditions:</i>	<i>Stop No.:</i>
--------------------	------------------	----------------------------	------------------

PART D: Safety and Security Features			
Section D-1: Traffic and Pedestrian Issues			
D1	Where is the bus stop area located?		
	In travel lane		<input type="checkbox"/>
	Bus lane/pull off area		<input type="checkbox"/>
	Paved shoulder		<input type="checkbox"/>
	In right turn only lane		<input type="checkbox"/>
	Unpaved shoulder		<input type="checkbox"/>
	Off street		<input type="checkbox"/>
	“No Parking” portion of street parking lane		<input type="checkbox"/>
Other (specify):		<input type="checkbox"/>	
D2	Is the bus stop zone designated as a no parking zone?		Yes No <input type="checkbox"/> <input type="checkbox"/>
	<i>If YES, indicated by:</i>		
	One “No Parking” sign		<input type="checkbox"/>
	2 or more “No Parking” signs		<input type="checkbox"/>
	“Bus Only” sign		<input type="checkbox"/>
	Painted curb		<input type="checkbox"/>
	Painted street		<input type="checkbox"/>
D3	Are cars parked between the landing area and the bus stopping area?		Yes No <input type="checkbox"/> <input type="checkbox"/>
D4	What is the posted speed limit in MPH?	Not posted	<input type="checkbox"/>
D5	What are the traffic controls at the nearest intersection for the street?		
	Traffic signals		<input type="checkbox"/>
	Flashing lights		<input type="checkbox"/>
	Stop/Yield sign		<input type="checkbox"/>
	None		<input type="checkbox"/>
Other (specify):		<input type="checkbox"/>	

<i>Date</i>	<i>Time:</i>	<i>Surveyor:</i>
-------------	--------------	------------------

BUS STOP CHECKLIST

PART D: SAFETY AND SECURITY FEATURES

<i>Route Name:</i>	<i>Location:</i>	<i>Weather Conditions:</i>	<i>Stop No.:</i>
--------------------	------------------	----------------------------	------------------

D6	How many total lanes are on both sides of the road?	1 <input type="checkbox"/>	2 <input type="checkbox"/>	3 <input type="checkbox"/>	4 <input type="checkbox"/>	Other (specify): <input type="checkbox"/>	N/A <input type="checkbox"/>
							Yes No N/A <input type="checkbox"/> <input type="checkbox"/> <input type="checkbox"/>
D7	Is there on-street parking permitted just before or after the bus stop zone?						
	<i>If YES, what is the length of the "No Parking" area in feet:</i>						
D8	Are there potential traffic hazards?						Yes No <input type="checkbox"/> <input type="checkbox"/>
	<i>Yes, check all that apply:</i>						
	The bus stop is just over the crest of a hill						<input type="checkbox"/>
	The bus stop is just after a curve in the road						<input type="checkbox"/>
	The bus stop is near an at-grade railroad crossing						<input type="checkbox"/>
	Waiting passengers are hidden from view of approaching bus						<input type="checkbox"/>
	A stopped bus straddles the crosswalk						<input type="checkbox"/>
	Bus stop just before crosswalk						<input type="checkbox"/>
	High speed traffic						<input type="checkbox"/>
	No crosswalk						<input type="checkbox"/>
	Other (specify)						<input type="checkbox"/>
D9	Additional traffic safety comments / recommendations:						
Section D-2: Lighting Assessment (assessment preferably taken in the evening or at night) Go to Section D-3 if no lighting							
D10	What type of lighting is available?						
	Street light						<input type="checkbox"/>
	Shelter lighting						<input type="checkbox"/>
	Outside light on adjacent building						<input type="checkbox"/>
	Other (specify):						<input type="checkbox"/>

<i>Date</i>	<i>Time:</i>	<i>Surveyor:</i>
-------------	--------------	------------------

BUS STOP CHECKLIST

PART D: SAFETY AND SECURITY FEATURES

<i>Route Name:</i>	<i>Location:</i>	<i>Weather Conditions:</i>	<i>Stop No.:</i>
--------------------	------------------	----------------------------	------------------

D11	Does the light produce a glare?	Yes No <input type="checkbox"/> <input type="checkbox"/>
D12	How even is the light distributed?	Yes No <input type="checkbox"/> <input type="checkbox"/>
D13	Additional comments:	

Section D-3: Pay Phone

D14	Is there a pay phone within the immediate vicinity? <i>If NO, skip to Question D16.</i>	Yes No <input type="checkbox"/> <input type="checkbox"/>
D15	Is the pay phone within reach of a wheelchair user?	Yes No <input type="checkbox"/> <input type="checkbox"/>
D16	If no pay phone is provided, is there a police call box?	Yes No <input type="checkbox"/> <input type="checkbox"/>
D17	Additional comments:	

Section D-4: Landscaping Assessment

D18	Are there problems with the landscaping around the bus stop? <i>If YES, check all that apply:</i>	Yes No <input type="checkbox"/> <input type="checkbox"/>
	Trees/bushes encroaching on the landing area	<input type="checkbox"/>
	Trees/bushes encroaching on the sidewalk	<input type="checkbox"/>
	Tree branches that would hit the bus	<input type="checkbox"/>
	Other (specify):	<input type="checkbox"/>

<i>Date</i>	<i>Time:</i>	<i>Surveyor:</i>
-------------	--------------	------------------

BUS STOP CHECKLIST**PART D: SAFETY AND SECURITY FEATURES**

<i>Route Name:</i>	<i>Location:</i>	<i>Weather Conditions:</i>	<i>Stop No.:</i>
--------------------	------------------	----------------------------	------------------

D19	Additional comments:
------------	----------------------

Section D-5: Safety Recommendations

D20	Improve pedestrian safety by:	<input type="checkbox"/>
	Trim trees or branches	<input type="checkbox"/>
	Move bus stop to:	
	Other (specify):	

<i>Date</i>	<i>Time:</i>	<i>Surveyor:</i>
-------------	--------------	------------------

BUS STOP CHECKLIST

PART E: INFORMATION FEATURES

<i>Route Name:</i>	<i>Location:</i>	<i>Weather Conditions:</i>	<i>Stop No.:</i>
--------------------	------------------	----------------------------	------------------

PART E: Information Features		
E1	Is there a bus stop sign?	Yes No <input type="checkbox"/> <input type="checkbox"/>
	<i>If NO, move to question E6.</i>	
E2	What provider name is on the bus stop (<i>list all providers utilizing stop</i>)?	
	Provider 1:	
	Provider 2:	
	Provider 3:	
	Provider 4:	
E3	Are bus routes indicated on the bus stop sign?	Yes No <input type="checkbox"/> <input type="checkbox"/>
	<i>If YES, what routes?</i>	
E4	How is the sign installed?	
	On its own pole	<input type="checkbox"/>
	On a building	<input type="checkbox"/>
	On a utility pole	<input type="checkbox"/>
	On a shelter	<input type="checkbox"/>
	Other (specify):	<input type="checkbox"/>
E5	Are there problems with the signage?	Yes No <input type="checkbox"/> <input type="checkbox"/>
	<i>If YES, check all that apply:</i>	
	Sign in poor condition	<input type="checkbox"/>
	Pole in poor condition	<input type="checkbox"/>
	Sign position hazardous to pedestrians	<input type="checkbox"/>
	Sign not permanently mounted	<input type="checkbox"/>
	Lighting on sign is poor	<input type="checkbox"/>
	Other (specify):	<input type="checkbox"/>

<i>Date</i>	<i>Time:</i>	<i>Surveyor:</i>
-------------	--------------	------------------

BUS STOP CHECKLIST

PART E: INFORMATION FEATURES

<i>Route Name:</i>	<i>Location:</i>	<i>Weather Conditions:</i>	<i>Stop No.:</i>
--------------------	------------------	----------------------------	------------------

E6	Is there route/schedule/map (circle as appropriate) information posted?	Yes No <input type="checkbox"/> <input type="checkbox"/>
	<i>If NO please move to question E9.</i>	
E7	Where is the route/schedule/map (circle as appropriate) information posted?	
	On Pole under bus stop sign	<input type="checkbox"/>
	On its own pole	<input type="checkbox"/>
	On a building	<input type="checkbox"/>
	On a utility pole	<input type="checkbox"/>
	On a shelter	<input type="checkbox"/>
	In a shelter	<input type="checkbox"/>
	Other (specify):	<input type="checkbox"/>
E8	Is the information at eye level of a wheelchair user?	Yes No <input type="checkbox"/> <input type="checkbox"/>
E9	Is there a schedule rack?	Yes No <input type="checkbox"/> <input type="checkbox"/>
	<i>If YES, are repairs needed?</i>	Yes No <input type="checkbox"/> <input type="checkbox"/>
E10	Is there real time information display?	Yes No <input type="checkbox"/> <input type="checkbox"/>
	<i>If YES, is it at eye level of a wheelchair user?</i>	Yes No <input type="checkbox"/> <input type="checkbox"/>
E11	Is signage text ADA compliant (refer to the <i>Toolkit for the Assessment of Bus Stop Accessibility and Safety</i> for guidelines)?	Yes No <input type="checkbox"/> <input type="checkbox"/>
E12	Is information provided in Braille or by a Talking Signs® transmitter for people with visual impairments?	Yes No <input type="checkbox"/> <input type="checkbox"/>
E13	Additional signage & information comments:	
E14	Signage & information recommendations:	
	Make the following repairs:	<input type="checkbox"/>
	Other (specify):	<input type="checkbox"/>

<i>Date</i>	<i>Time:</i>	<i>Surveyor:</i>
-------------	--------------	------------------

BUS STOP CHECKLIST

PART F: DIAGRAMMATIC SKETCH OR PHOTOGRAPH

<i>Route Name:</i>	<i>Location:</i>	<i>Weather Conditions:</i>	<i>Stop No.:</i>
--------------------	------------------	----------------------------	------------------

PART F: Diagrammatic Sketch or Photograph

Sketch or photograph the layout of the bus stop area and any traffic controls. On sketch or photograph, be sure to note locations of:

Bus stop sign pole	Newspaper boxes	Traffic signals/stop signs
Other poles	Anything else installed at bus stop	Railroad tracks
Landing Pad	Sidewalks	Bus stop across the street
Shelter	Sidewalk barriers	Heating units in shelters
Bench	Crosswalks	Bike racks
Trash can	Curb cuts	North/South/East/West

<i>Date</i>	<i>Time:</i>	<i>Surveyor:</i>
-------------	--------------	------------------



CREATING ACCESSIBLE AND SAFE BUS STOPS

Distinction Between ADA Requirements and Universal Design⁵

Accessible design focuses on compliance with laws and regulations and state or local building codes. The laws and regulations are intended to eliminate certain physical barriers that limit the usability of environments for people with disabilities. These typically were based on the requirements detailed by the American National Standards Institute. With the passage of the Americans with Disabilities Act (ADA) in 1990 and the subsequent development of the ADA Accessibility Guidelines, accessible design has focused more recently on satisfying these minimum technical criteria to allow most people with disabilities to use the built environment. The ADA Standards are the minimum requirements that comply with the law. They are not necessarily “best practices.”

Universal design is intended to create environments that are usable by all people. While considerations for people with disabilities are certainly necessary for universal design, they are not sufficient when planning and designing for the whole population. Universal design provides a higher level of access for people with disabilities. It also accommodates the needs and wishes of everyone - e.g., children, older adults, women and men. Parents pushing strollers, travelers pulling luggage, the older man needing a little more time to cross a street - all benefit from features of universal design. For additional background information on universal design, visit the Global Universal Design Educator’s Network, <http://www.ueducation.org/>.



The ADA Standards are the minimum requirements that comply with the law. They are not “best practices.” Universal design is intended to create environments that are more usable by all people, including people with disabilities.

⁵ City of New York Office of the Mayor, *Universal Design New York*. Center for Inclusive Design and Environmental Access, School of Architecture and Planning, University at Buffalo, Buffalo, New York 2001.



This bus stop in New York City has a bus landing area that is free of obstructions for both front and rear doors. The sidewalk adjacent to the bus stop platform is wide enough to handle high pedestrian activity and for a wheelchair user to pass without entering the bus stop area.

Source: Metropolitan Transportation Authority

Design Guidelines

The following sections list accessibility benefits, minimum ADA requirements and universal design recommendations for the various elements of a bus stop.

Bus Stop Area and Bus Landing Pads

A bus stop platform is a designated bus stop area clear of obstructions to facilitate boarding and alighting for all users.

Accessibility Benefits

Providing a designated bus stop area benefits all transit users. An area the length of the bus for transit purposes provides a comfortable waiting, alighting and boarding area for both front and rear doors and denotes the transit agency's presence. Wheelchair users will have less difficulty boarding and alighting the bus when there is a stable, level and unobstructed landing pad to operate the wheelchair lift and ramp. Wheelchair and scooter users require more space to wait and turn around than other transit users and therefore benefit from sufficient area at the bus stop to maneuver.⁶

Minimum ADA Requirements

Providing accessible bus stops requires choosing appropriate locations or improving the existing location. Coordination and cooperation with public works agencies, municipal government and business owners can enhance the connectivity between the land use and the bus stop. To ensure optimum bus stop placement, coordination should occur during the planning/development phase.

Bus stop sites must have the following:⁷

- A firm, stable surface;
- A minimum clear length of 96 inches (2,440 millimeters), measured from the curb or vehicle roadway edge and a minimum clear width of 60 inches (1,524 millimeters), measured parallel to the vehicle roadway;

⁶ McMillen, Barbara et al. *Designing Sidewalks and Trails for Access: Part I of II: Review of Existing Guidelines and Practices*. 1999.

⁷ ADA Accessibility Guidelines for Buildings and Facilities (ADAAG), Section 10.

- A maximum slope of 1:50 (2%) for water drainage; and
- Connection to streets, sidewalks or pedestrian paths by an accessible route.

Universal Design

Finding the proper location for a bus stop is challenging. Community Transit in Everett, Washington enlists help from the agency’s bus drivers to determine where best to situate a stop. To test the potential locations, temporary markers, such as orange cones with bus stop signs, are installed and maintained while the local public is solicited for input.⁸

The bus stop platform guidelines outlined in this section are not required but are strongly recommended to facilitate accessibility and safety for all users.

- **Bus Stop Area⁹**
 - ✧ Locate street furniture to maintain a minimum clear width of 48 inches (1,219 millimeters) and clear headroom of 80 inches (2,032 millimeters) from the pedestrian pathway to the stop
 - ✧ Clear the bus stop platform of all obstacles (including trees, newspaper boxes, waste and recycling receptacles)
 - ✧ Design the sidewalk adjacent to the bus stop platform to be wide enough to handle the expected levels of pedestrian activity and for two wheelchair users to pass each other traveling in opposite directions when two-way traffic is frequent
- **Bus Stop Area - Door Clearances¹⁰**
 - ✧ The front and rear door areas of a bus stop should be kept clear of trees, utility poles, wires, hydrants and other infrastructure or street furniture. Because different types and sizes of buses are used, all bus stop platforms should account for the variance in door positions.

- **Types of Bus Stop Areas**

Various configurations of bus stop areas are available to accommodate passenger waiting, boarding and alighting. Determining the type of platform to use depends on traffic conditions, bus priority, space availability and the number of users at the stop.

⁸ Nelson\Nygaard, Interview with Tony Smith, Community Transit, March 31, 2005.

⁹ Transit Cooperative Research Program (TCRP) Report 19 *Guidelines for the Location and Design of Bus Stops* 1996.

¹⁰Province of Alberta, Transportation & Utilities, 1996.



The parked car leaves little clearance for the bus to pull in flush to the curb.

Picture taken in Oakland, California.
Source: NelsonNygaard Consulting Associates



This bus bay in Tucson, Arizona prohibits parking and denotes a wheelchair accessible area.

Source: NelsonNygaard Consulting Associates

- **Curbside stop**

Curbside stops are typically installed on existing sidewalks. In urban areas, the stop is located in the parking lane. The length of the stop's curb may be painted a distinctive color to prevent or discourage parking. In suburban areas, the curbside stop may be located in the travel lane as the street may not incorporate a parking lane.

Advantages of Curbside Stops
<ul style="list-style-type: none"> • Provides access to bus stops • Simple in design and inexpensive for transit agency to install
Disadvantages of Curbside Stops
<ul style="list-style-type: none"> • May present problems for drivers trying to pull in flush to the stop's curb if not enough entering clearance is given due to parked cars (as shown in the picture to the left) • May present problems for bus drivers trying to reenter traffic, especially during periods of high volume traffic

- **Bus Bay¹¹**

Bus bays provide an area for buses to leave the main road to pick up passengers. They often have a shelter and other amenities for the waiting passenger.

Advantages of Bus Bays
<ul style="list-style-type: none"> • Allows passengers to board and alight out of the travel lane • Provides a protected area away from traffic for both the stopped bus and patrons • Minimizes delay to through traffic
Disadvantages of Bus Bays
<ul style="list-style-type: none"> • May present problems for bus drivers trying to reenter traffic, especially during periods of high volume traffic • Is expensive to install compared to curbside stops • Is difficult and expensive to relocate

¹¹ Transit Cooperative Research Program (TCRP) Report 19, 1996.

- **Bus Bulb**

Advantages of Bus Bulbs
<ul style="list-style-type: none"> • Allows drivers to pull in flush to the curb • Results in minimal delay to the bus
<ul style="list-style-type: none"> • Allows for more waiting room for bus patron separated from the pedestrian flow and space for amenities
Disadvantages of Bus Bulbs
<ul style="list-style-type: none"> • Can cause traffic to queue up behind the bus, causing traffic delay • Expensive to install compared to curbside stops • Difficult and expensive to relocate

- **Amenities**

The bus stop platform can benefit from various amenities and treatments. These are discussed in the Amenities Section.



A bus bulb in San Francisco, California. The bus stop area is extended into the parking lane and incorporates a shelter that does not impede the pedestrian right of way. The bulb allows the bus driver to pull up flush to the curb to facilitate the boarding and alighting of passengers.

Source: NelsonNygaard Consulting Associates



Examples of Bus Stop Areas and Landing Pads

The pictures on this page give examples of bus stops with good and poor accessibility.



The lack of a stable and firm landing pad and accessible path makes this stop in British Columbia inaccessible. Rider safety is compromised as the poor drainage and grassy/muddy waiting area create slippery conditions.

Source: BC Transit



This stop in Berkeley, California does not have adequate clearance to deploy a wheelchair ramp. Additionally, the stop lacks identity, being indiscernible from a newspaper vending machine area.

Source: NelsonWygaard Consulting Associates



The stop area and landing pad are clear of obstructions in Oakland, California. There is enough room for wheelchair users to maneuver, and the stop is spatially and visually distinct from the pedestrian walkway.

Source: NelsonWygaard Consulting Associates

Bus Shelter Design

A bus shelter provides protection from the elements and seating while waiting for a bus. Standardized shelters exist that accommodate various site demands and passenger volumes. Typically, a shelter is constructed of clear side-panels for visibility and safety.

Accessibility and Safety Benefits

The seating and protection provided by shelters benefits bus patrons with mobility impairments. Additionally, a shelter clearly marks a bus stop, supplies an area to post route and timetable information and provides refuge for waiting passengers, separated from the public way. Shelters located in areas with good lighting and visibility from surrounding land uses enhance the safety of the stop.

Minimum ADA Requirements¹²

Install new or replace bus shelters to accommodate the following:

- A minimum clear floor area of 30 inches by 48 inches (762 millimeters by 1,219 millimeters), entirely within the perimeter of the shelter; and
- Connected by an accessible route to the bus stop landing pad.

Additionally,

- Bus stop shelters should not be placed on the wheelchair landing pad
- General ADA mobility clearance guidelines should be followed around the shelter and between the shelter and other street furniture
- A clearance of 36 inches (914 millimeters) should be maintained around the shelter and an adjacent sidewalk (more is preferred)



¹² ADA Accessibility Guidelines for Buildings and Facilities (ADAAG), Section 10.



Universal Design¹³

When to Install a Shelter

The decision to install a shelter is the result of system-wide policy among transit agencies. In most instances, the estimated number of passenger boardings is the most important determinant. Suggested boarding levels by area type used to decide when to install a shelter are as follows (these values represent a composite of prevailing practices):

Location	Minimum Boardings
Rural	10 boardings per day
Suburban	25 boardings per day
Urban	50 to 100 boardings per day

Location

Ideally, the location of a bus stop shelter should enhance the circulation patterns of patrons, reduce the amount of pedestrian congestion at a bus stop, and reduce conflict with nearby pedestrian activities. The following guidelines should be used when placing a bus stop shelter at a stop:

- Permit clear passage of the bus and its side mirror with a minimum distance of 24 inches (610 millimeters) between the back-face of the curb and the roof or panels of the shelter. Greater distances are preferred to separate waiting passengers from nearby vehicular traffic
- Locate the shelter as close as possible to the end of the bus stop zone and provide visibility to approaching buses and passing traffic
- Preserve a 12-inch (305 millimeter) clear space to permit trash removal and cleaning of the shelter when shelters are directly adjacent to a building

Design Considerations

Shelter design is based on criteria related to climate, agency, policies and streetscape context. The following are general design guidelines that assist in providing accessibility and safety:

- Incorporate shelter dimensions that are 9 feet long and 5 feet wide (2.7 meters by 1.5 meters)



The bus shelter is placed on a concrete block that is level with the sidewalk. It provides a stable surface for wheelchair users and does not impose on the bus landing pad area. *Photo taken in Mableton, Georgia.*

Source: G. Araki www.the-bus-stops-here.org

¹³ Transit Cooperative Research Program (TCRP) Report 19, 1996.

- Design shelters with transparent sides for visibility and security¹⁴
- Mark glass panels with distinctive pattern such as horizontal contrasting strips or circles, to indicate the presence of the panels
- Include transit route maps, schedules, and seating in shelters. Maps and schedules should be easily readable by persons using wheelchairs and, to the greatest extent possible, persons with visual impairments
- Provide seating, if feasible, with sufficient space to move around
- Provide surfaces to lean against if seating is not provided
- Omit steps between the sidewalk/bus pad and the shelter
- Maintain shelter openings to be a minimum of 36 inches (914 millimeters) clear to allow a wheelchair to pass through
- Consider heated shelters at high ridership stops in cold climates.

Seating

Seats provide comfort to waiting customers and increase the attractiveness of the bus service, especially for those with mobility impairments. Patrons who have difficulty standing will benefit from seating and will more likely use transit services. Seating located in the shelter should leave clear space for patrons with wheelchairs to use the shelter.

Environmental Controls

In orienting and configuring bus shelters, personnel should consider the environmental characteristics of each site. Shelters can be completely open to permit unlimited movement of air in hot climates, or panels can be erected to keep the interior of the bus shelter warm. The following examples provide guidance on the type and placement of shelters for various climates:

- **Cold Climates**

In areas where winter temperatures are low, installing shelters with wind protection and investing in heated shelters for large bus stops and transfer points may provide incentive for customers to use the transit service.



This shelter in Rochester, New York, provides two openings for entering and exiting, as well as wind protection from the northern climate.

Source: Rochester Genesee Regional Transportation



These two shelters in Toronto, Canada, open onto the sidewalk to provide protection from snow or water splashed by moving cars. The shelter is enclosed except for the entranceway to protect against inclement weather.

Source: SUNY Buffalo

¹⁴ Province of Alberta, Transportation & Utilities, 1996.



This shelter located in Palm Springs, California allows air to circulate. The panels are constructed of perforated metal to allow airflow while maintaining good visibility of the surrounding area.

Source: Robert Perrone Consulting



Shelter with advertising placed downstream of traffic flow and good visibility in Oakland, California.

Source: Nelson/Nygaard Consulting Associates

- **Hot Climates**

In southern climates with mild winter temperatures and extreme summer temperatures, shelters can be designed to be completely open to air circulation from all four sides. At sites with wind, rain, or glare problems, standardized shelters can be retrofitted with panels to provide protection and shade. In the Southwestern region of the United States, air temperatures can reach above 110 degrees Fahrenheit on a regular basis during the summer. Transit agencies can induce people to ride the bus in these conditions by providing cool air misters and evaporation cooling towers.

Location of Advertising

Many transit agencies have paid advertising in bus shelters to reduce costs and to provide other benefits. Passenger and pedestrian safety and security are of greater concern at shelters with advertising. The advertising panels may limit views in and around a bus stop, making it difficult for bus drivers to see patrons. The panels can also reduce incidental surveillance from passing traffic. To prevent restricted sight lines, advertising panels should be placed downstream of the traffic flow, to assist an approaching bus driver view the interior of the shelter easily. Indirect surveillance from passing traffic should be preserved through proper placement of the panels.¹⁵

¹⁵ Transit Cooperative Research Program (TCRP) Report 19, 1996.

Lighting

Lighting affects bus patrons' perception of safety and security at a bus stop, as well as the use of the site by non-bus patrons. Good lighting can enhance a waiting passenger's sense of comfort and security; poor lighting may encourage unintended use of the facility by non-bus patrons, especially after hours. Lighting is particularly important in northern climates where patrons may arrive and return to the stop in darkness during the winter season.¹⁶

Accessibility Benefits

Bus patrons who have low visibility in dimly lighted areas benefit from good lighting at and around the bus stop. As stated before, lighting benefits all users by increasing the safety and security of the stop.

Minimum ADA Requirements

No specific ADA lighting requirements.

Universal Design

The following are highly recommended to provide a safe waiting environment:

- Installing lighting that provides between 2 to 5 footcandles.¹⁷ A footcandle is a unit of illuminance on a surface that is a uniform point source of light of one candela and equal to one lumen per square foot.¹⁸
- Illuminating bus patron's faces. Multiple sources of light are more resistant to vandalism and provide illumination that casts fewer intimidating shadows. Lighting that is too bright in bus shelters can also compromise personal safety, creating a fish bowl effect whereby the transit user can easily be seen by others but cannot see outside.¹⁹

¹⁶ Transit Cooperative Research Program (TCRP) Report 19, 1996.

¹⁷ Transit Cooperative Research Program (TCRP) Report 19, 1996.

¹⁸ Merriam-Webster Online, <http://www.m-w.com/cgi-bin/dictionary?va=foot-candles>

¹⁹ Vogel, Mary and Pettinari, James L., *Personal Safety and Transit: Paths, Environments, Stops, and Stations* Center for Transportation Studies, University of Minnesota 2002.



Indirect lighting illuminates the shelter and sidewalk in New York City, New York. The shelter is constructed with glass panels on all four sides, providing good visibility and better security.

The shelter is designed with vandal proof, flexible PV cells with hidden batteries and energy efficient LEDs. Solar electricity is stored during the day to provide security at night. There is no connection to a grid or excavation costs to install electricity.

Source: SUNY Buffalo

- Ensuring light fixtures are vandal-proof but easily maintained. For example, avoid using exposed bulbs or elements that can be easily tampered with or destroyed.²⁰
- Locating bus stops near existing streetlights for indirect lighting. When coordinating bus shelter or bench locations with existing streetlights, the minimum clearance guidelines for the wheelchairs should be followed.²¹ Several transit agencies have installed shelters with solar panels so that light can be provided “free” even in remote areas.

Security²²

Passenger security is a major issue in bus stop design and location and can positively or negatively influence a bus patron’s perception of the bus stop. From the perspective of security, landscaping, walls, advertising panels, and solid structures can restrict sight lines and provide spaces to hide. Each of these items can be an integral part of the bus stop, either by design or by proximity of existing land uses. Therefore, the transit and public works agencies should carefully review which amenities are to be included at a bus stop and consider any factors that may influence security.

Accessibility Benefits

Security provisions enhance accessibility by increasing visibility of the stop. They reduce the safety concerns of waiting at the stop at all hours, improve visibility from the stop and also provide information that is useful for planning trips and maintaining personal safety.

Minimum ADA Requirements

No specific ADA security requirements.

²⁰ Transit Cooperative Research Program (TCRP) Report 19, 1996.

²¹ Ibid.

²² Ibid.

Universal Design

Some guidelines regarding security at bus stops are as follows:

- Constructing the bus shelter of materials that allow clear, unobstructed visibility of and to patrons waiting inside
- Locating bus stops at highly visible sites to permit approaching bus drivers and passing vehicular traffic to see the bus stop clearly. Proximity to stores and businesses also enhance surveillance of the site
- Limiting landscaping elements to low-growing shrubbery, ground cover and deciduous shade trees are preferred at bus stops. Evergreen trees provide a visual barrier and should be avoided
- Coordinating bus stops with existing street lighting to improve visibility.
- Maintaining the cleanliness of the bus stop. A well-maintained stop contributes to the concept of an owned environment. Refer to the Maintenance Section for more information
- Providing a Pay Phone or Police Call Box to allow emergency calls
- Providing accurate route and schedule information

Accessible Path

Walkways or sidewalks are essential links between the origin/destination of the trip and the bus stop. Their proper design and regular maintenance are important to providing a barrier-free travel path for all persons.

Accessibility Benefits

Accessible paths allow all users to reach their destination conveniently and safely. For users of mobility devices, an unobstructed, stable and wide pathway to the bus stop will facilitate use of the bus system. Wheelchair and scooter users require a wider path of travel than ambulatory pedestrians. Additionally, their stability and control can be affected by surfaces with cross-slopes, grades, or rough terrain. Cross-slopes that change very rapidly cause problems for wheelchair users. The rate of change of cross-slope is most problematic when it occurs over a distance of less than 24 feet (610 millimeters), the approximate distance covered by a wheelchair wheelbase.²³

²³ McMillen, Barbara et al. 1999.



People who use walking aids include those who use canes, crutches, or walkers to ease their ambulation. The limitations of walking-aid users might include the following:²⁴

- Difficulty negotiating steep grades
- Difficulty negotiating steep cross-slopes
- Decreased stability
- Slower walking speed
- Reduced endurance
- Inability to react quickly to dangerous situations
- Reduced floor reach

Minimum ADA Requirements²⁵

At minimum, an accessible path should accommodate the following:

- A minimum clear passage width of 48 inches (1,219 millimeters) is recommended by the Access Board's guidelines for the public right-of-way. This is especially important next to a curb drop-off;
- An accessible route from public transportation stops to the route for the general public;
- A maximum cross slope of 1:50;
- Stable, firm and slip-resistant ground and floor surfaces; and
- Grating spaces that are no greater than 9 1/2 inches (13 millimeters) wide in one direction.

Objects may not protrude on an accessible route or maneuvering space. Guidelines for protruding objects are below:²⁶

- Objects projecting from walls (for example, telephones) with their leading edges between 27 inches and 80 inches (685 millimeters and 2,030 millimeters) above the finished floor shall protrude no more than 4 inches (100 millimeters) into pathway;
- Objects mounted with their leading edges at or below 27 inches (685 millimeters) above the finished floor may protrude any amount;

²⁴ McMillen, Barbara et al. 1999.

²⁵ ADA Accessibility Guidelines for Buildings and Facilities (ADAAG), Section 4.3.

²⁶ Ibid.

- Free-standing objects mounted on posts or pylons may overhang 12 inches (305 millimeters) maximum from 27 inches to 80 inches (685 millimeters to 2,030 millimeters) above the ground or finished floor;
- 80 inches (2,030 millimeters) minimum clear headroom. If vertical clearance of an area adjoining an accessible route is reduced to less than 80 inches (nominal dimension), provide a barrier to warn blind or visually-impaired persons.

Universal Design

- Sidewalks²⁷
 - ✎ Widen sidewalks to five or more feet to accommodate pedestrian activity in two directions and provide comfortable bus stop waiting area
 - ✎ Maintain walkways and bus stop areas to be clear of snow, ice and other debris
 - ✎ Provide an accessible travel path that is the shortest distance between the bus stop and the sidewalk or accessible building
 - ✎ Distinguish the surface of the bus stop from the surrounding areas to accommodate persons with visual impairments. The use of different textures, such as concrete, paving stone, contrasting colors, tactile strips and curbs help to delineate pathways
- Street Furniture and Other Obstacles in Travel Path
 - ✎ Locate street furniture and signage, such as benches, sign posts, newspaper boxes out of the travel path of pedestrians and transit passengers
 - ✎ Define pathway junction points and clear them of obstructions

- Curb Ramps

Grade-level changes are difficult for the elderly and persons with disabilities to negotiate. Any grade-level change without the aid of a curb ramp creates a mobility barrier. Refer to ADAAG Section 4.7 on Curb Ramps for more information.



Example of a curb ramp leading to a bus stop in Buffalo, New York.

Source: SUNY Buffalo

²⁷ Province of Alberta, Transportation & Utilities, 1996.



An accessible path is provided to and from the stop, linking the stop to the surrounding land uses in Eugene, Oregon.

Source: G. Araki www.the-bus-stops-here.org.



The lack of an accessible path makes it difficult for a wheelchair user to use this stop in Red Bluff, California. All users would have to travel on gravel and on the roadway shoulder to use the stop.

Source: G. Araki www.the-bus-stops-here.org.

Examples of Bus Stops with and without Accessible Paths

Ensuring that there is an unobstructed, stable and slip resistant path to the bus stop is essential to providing access to the bus for people with disabilities. The following examples show a stop that is well connected and others that are inconvenient for all bus patrons.



This bus stop in Buffalo, New York is not accessible, lacking a plowed path to the shelter. Bus patrons with and without disabilities will have difficulty getting to the stop and getting onboard the bus due to the thick layer of snow.

As it is difficult to clear snow from every bus stop, particularly those in residential neighborhoods, an agreement with property managers or residents may help with snow removal (refer to Adopt-a-Stop Program programs). In this case, an agreement between the transit agency and the property manager of the building adjacent to the stop can ensure that the bus stop and a path leading to the stop are cleared of snow when the parking lot is plowed.

Source: SUNY Buffalo

Route and Timetable Information²⁸

Route and passenger information can be displayed in various ways. A flag sign is the most common method used by transit agencies to display information. Schedule holders and route information on the shelters are also commonly used.

Accessibility Benefits

Reducing transit's ambiguity in terms of arrival time and route allows those with cognitive disabilities and general transit riders to use the system more effectively.

Minimum ADA Requirements

Follow ADA requirements on Accessible Path, Signage and Protruding Objects for access to information by individuals with disabilities (see sections on Accessible Path and Transit Signage).

Universal Design

Recommendations for route or patron information displays are as follows:

- Provide updated information when changes are made to routes and schedules
- Consider the quality and appearance of information displays. A visually poor route map conveys a negative impression of the system
- Make information displays permanent. Temporary methods for displaying information (such as taping) create a cluttered, unsophisticated appearance at the bus stop
- Shelters or stops should be designed to accommodate route and schedule information so it is not added in places that reduce visibility or security
- Use interior panels of shelters for posting route and schedule information. Side panels may be large enough to display the entire system map and can include backlighting for display at night
- Install real time information display boards at key stops to give patrons up to the minute information on bus arrival times and delays. For people with visual impairments, a button may be provided that gives audio information when pressed. A discussion of real time information is included in the Technology and Product Links section.



Example of good route information and placement in Loveland, Colorado. The information is not cluttered, and is provided in a prominent location, which reduces ambiguity in using the service.

Source: Access Compliance Services

	8th St @ Lincoln	Good Samaritan Village	28th East of Duffield
1	6:38	6:46	6:54
	7:38	7:46	7:54
	8:38	8:46	8:54
	9:38	9:46	9:54
	10:38	10:46	10:54

This picture provides a close-up of the timetable information provided in the above figure. The schedule is provided in large, easy to read text.

Source: Access Compliance Services

²⁸ Transit Cooperative Research Program (TCRP) Report 19, 1996.



The bus stop pole in Seattle, Washington displays the routes servicing the stop on a flag and timetables in an information panel. The information panel is at eye level of a wheelchair user.

Source: Sound Transit

Transit Signage

Proper signs at bus stops are an important element of good transit service. Signs serve as a source of information to patrons and operators regarding the location of the bus stop and are excellent marketing tools to promote transit use. Letter styles, sign appearance, and color choice should be unique to the transit system so that passengers can readily identify bus stops.

Accessibility Benefits

Transit signs are usually installed in an accessible position on the bus stop landing pad. For patrons using wheelchairs, the bus stop pole usually indicates where to access the wheelchair lift. To indicate the stop location for a patron who has visual impairments, the sign pole may be stylized to distinguish it from other poles on the path. For example, a perforated square pole uniquely identifies the stop. In Vancouver, British Columbia, a pole collar serves as a tactile marker.

Minimum ADA Requirements²⁹

Provide bus stop signage that accommodates the following:

- Letters and numbers to be a width-to-height ratio between 3:5 and 1:1 and a stroke-width-to-height ratio between 1:5 and 1:10;
- Characters and numbers sized according to the viewing distance from which they are to be read;
- Minimum height is measured using an upper case X. Lower case characters are permitted;
- Accompany pictograms with the equivalent verbal description placed directly below, with a border dimension of 6 inches (152 millimeters) minimum in height;
- Characters and background of signs in a non-glare finish, with characters and symbols contrasting from their background; and
- Follow protruding objects requirements (given in the section Accessible Path)

²⁹ ADA Accessibility Guidelines for Buildings and Facilities (ADAAG), Section 4.30.

Universal Design³⁰

Unlike other traffic signs, which conform to national engineering standards, transit signage is typically unique to each individual transit property. Customer information signs should be readily identifiable, legible, clear, and consistent not only for the general public but also for persons with disabilities. The following considerations for signs are recommended:

- Providing doublesided signs for visibility from both directions and reflectorized or illuminated signs for nighttime visibility
- Placing bus stop signs at the location where people board the front door of the bus. The bus stop sign marks the area where passengers should stand while waiting for the bus and serves as a guide for the bus operator in positioning the vehicle at the stop. The bottom of the sign should be at least 7 feet (2.1 meters) above ground level and should not be located closer than 2 feet (0.6 meters) from the curb face
- Deciding locations for bus stops and signposts should be coordinated with local and/or state jurisdictions.
- Ensuring that the signs are not obstructed by trees, buildings, or other signs and located away from visual distractions

Refer to Transit Cooperative Research Program (TCRP) Report 12, *Guidelines for Transit Facility Signing and Graphics* (http://gulliver.trb.org/publications/tcrp/tcrp_rpt_12-a.pdf) for detailed information on transit signage. One section of the report, highlighted in Figure 1 below, provides guidance on acceptable color combinations for signs based on contrast. Color contrast is of critical importance to persons with visual impairments. When selecting colors for information/guidance and directional signs, care should be taken to select colors that provide adequate contrast between the background and the characters, images, or pictographs.

³⁰ Transit Cooperative Research Program (TCRP) Report 19, 1996.



Figure 1. Acceptable Color Combinations Based on Contrast³¹

	Beige	White	Dark Grey	Black	Brown	Pink	Purple	Green	Orange	Blue	Yellow	Red
Red												
Yellow												
Blue												
Orange												
Green												
Purple												
Pink												
Brown												
Black												
Dark Grey												
White												
Beige												

Acceptable (70% contrast or greater)

Do not use

³¹ Transit Cooperative Research Program (TCRP) Report 12, *Guidelines for Transit Facility Signing and Graphics* 1996.

Amenities

Amenities benefit all transit patrons, if they do not reduce the minimum clear spaces required by ADAAG. This section outlines the optimal placement of various amenities.

Benches

Accessibility Benefits

Transit users who experience difficulty walking and standing benefit from benches while waiting for the bus. Benches are beneficial when a shelter with seating is not provided and if bus headways are longer than 15 minutes. At stops with high ridership, benches may be provided in addition to shelters to accommodate patrons.

Minimum ADA Requirements³²

If benches are provided, they should adhere to the following ADA regulations:

- Clear floor or ground space for wheelchairs (complying with ADAAG Section 4.2.4);
- Seat dimensions: 20 inches (510 millimeters) minimum to 24 inches (610 millimeters) maximum in depth and 42 inches (1,065 millimeters) minimum in length;
- Seat height: 17 inches (430 millimeters) minimum to 19 inches (485 millimeters) maximum above the floor or ground;
- Back support: 42 inches (1,065 mm) minimum in length and that extends from a point 2 inches (51 mm) maximum above the seat to a point 18 inches (455 mm) minimum above the seat;
- Structure supporting vertical or horizontal forces of 250 pounds. (1,112 Newtons) applied at any point on the seat, fastener, mounting device, or supporting structure; and
- Exposed benches: slip resistant and designed to shed water

Universal Design³³

The following recommendations coordinate bench placement with the bus stop environment to enhance safety and accessibility:

- Provide 17-inch (430 millimeter) high benches. Higher benches will be uncomfortable for many users
- Coordinate bench locations with existing shade trees if possible. Otherwise, install landscaping to



Example of a bench-only stop in Boise, Idaho. The bench is not located on the bus landing pad and does not impede access to the stop.

Source: G. Araki www.the-bus-stops-here.org.



The exterior bench at a stop in Greeley, Colorado is poorly placed, obstructing accessibility on the landing pad and into the shelter. The stop would otherwise be accessible, with a path connecting the stop to the sidewalk and a suitable landing pad, if the bench was not placed in its current location.

Source: Access Compliance Services 2005

³² ADA Accessibility Guidelines for Buildings and Facilities (ADAAG), Section 4.37.

³³ Transit Cooperative Research Program (TCRP) Report 19, 1996.



provide protection from the wind and other elements. Uncomfortable bus stop environmental conditions, such as heat or sun, can discourage use of the bench, forcing patrons to find another place to wait for their bus

- Coordinate bench locations with existing streetlights to increase visibility and enhance security at the stop
- Locate benches on a non-slip, properly drained, concrete pad. Avoid locating benches in undeveloped areas of the right-of-way
- Provide grab handles along the bench for patrons to use as support when standing up (refer to the Rochester, New York photo on page 41 for an example of benches inside a shelter with multiple grab handles)
- Locate benches away from driveways to enhance patron safety and comfort
- Maintain a minimum separation of 24 inches (610 millimeters) (preferably 4 feet or 1,219 millimeters) between the bench and the back-face of the curb. As the traffic speed of the adjacent road increases, the distance from the bench to the curb should be increased to ensure patron safety and comfort
- Maintain general ADA mobility clearances between the bench and other street furniture or utilities at a bus stop
- Avoid installing the bench on the wheelchair landing pad.
- Provide additional waiting room near the bench (preferably protected by landscaping) at bench-only stops to encourage bus patrons to wait at the bus stop
- Avoid metal seating surfaces. Such surfaces are very cold in winter and very hot in summer

Vending Machines³⁴

Vending machines can provide passengers with reading material while they wait for the bus. However, for local, non-commuter routes, vending machines can be undesirable for the following reasons:

- The machines are often poorly maintained and reduce the amount of room for mobility and waiting; and
- Trash accumulates at bus stops with vending machines. Trash removal is time-consuming and costly.

³⁴ Transit Cooperative Research Program (TCRP) Report 19, 1996.

Transit agencies have limited regulatory authority concerning the placement of vending machines. Newsprint companies usually seek high-profile sites to locate their machines. Transit agencies should review the need for the installation of vending machines at bus stops or coordinate with their jurisdiction to implement a consolidated vending rack program. The benefits to patrons of having the machines near the stop versus having to maintain trash receptacles and keep the area free of improperly disposed material should be considered.

If vending machines are provided, they should be anchored to the ground to reduce vandalism. ADA mobility guidelines should be followed for improved site circulation. Vending machines, newspaper boxes and other street furniture cannot reduce the minimum clear spaces required by ADAAG.

Bicycle Storage Facilities³⁵

Bicycle storage facilities, such as bike racks, may be provided at bus stops for the convenience of bicyclists using transit. Designated storage facilities discourage bicycle riders from locking bikes onto the bus facilities or on an adjacent property. Proper storage of bicycles can reduce the amount of visual clutter and ensure a clear pathway. ADA mobility guidelines should be followed in bicycle storage placement.

Trash Receptacles³⁶

Trash receptacles can improve the appearance of a bus stop by providing a place to dispose of trash. The installation of trash receptacles is typically a system-wide decision and the size, shape, and color reflect transit agency or public works department policy. ADA mobility guidelines should be followed in receptacle placement to ensure circulation.

Shopping Cart Storage³⁷

Proper storage for shopping carts at bus stops adjacent to commercial shopping centers is needed. Because such bus stops normally do not have storage facilities for shopping carts, carts often litter the area



The consolidated vending racks in Berkeley, California contain various publications, including newspapers and rental magazines.

Source: Nelson/Nygaard Consulting Associates

³⁵ Transit Cooperative Research Program (TCRP) Report 19, 1996.
³⁶ Ibid.
³⁷ Ibid.



This transit center in Lakewood, Washington, provides an area to store shopping carts to help prevent random placement of carts in and around the center.

Source: Pierce Transit

around the stop and along the sidewalk leading to the stop. The sight of haphazardly placed shopping carts around a bus stop is visually unappealing and can block sidewalk accessibility.

Since shopping carts are generated by the shopping center, agreements should be made between the landowner and the transit agency to remove the carts regularly. One solution is to install a storage facility near the bus stop to prevent random storage in and around the stop. Factors affecting installation of a storage facility include the location of the sidewalk, available right-of-way, utilities, landscaping, terrain, and cost. Any cart storage facility should follow ADA circulation guidelines and remain clear of the sidewalk and wheelchair landing pad area.

Communications

Public telephones

Accessibility & Safety Benefits

Telephones at bus stops offer many potential benefits for bus patrons, including the ability to make personal and emergency calls while waiting for the bus.

Minimum ADA Requirements³⁸

Provide telephones that adhere to the following:

- Where public telephones are provided, at least one telephone should be accessible by persons using wheelchairs. It must be located so that the receiver, coin slot and control are no more than 48 inches (1,219 millimeters) above the floor;
- A clear floor or ground space at least 30 inches by 48 inches (762 millimeters by 1,219 millimeters), not impeded by bases, enclosures, and fixed seats, that allows either a forward or parallel approach by a person using a wheelchair;
- The highest operable part of the telephone and telephone books within the reach ranges specified in ADAAG Sections 4.2.5 or 4.2.6;
- Location follows guidelines detailed in the section on Accessible Path;
- Hearing Aid Compatible and Volume Control equipped in Accordance with ADAAG Section 4.1.3; and
- Length of cord a minimum of 29 inches (735 millimeters) long.

³⁸ ADA Accessibility Guidelines for Buildings and Facilities (ADAAG), Section 4.31.

Universal Design³⁹

Experience with pay phones at bus stops has given mixed results. For example, inclusion of phones at bus stops can create opportunities for illegal or unintended activities, such as drug dealing and loitering, compromising the safety in and around bus stops. Loitering by non-bus patrons at bus stops appears to increase with the installation of phones; this may discourage bus patrons from using the facility.

When locating a phone at a bus stop, the following guidelines should be considered:

- Separate the phone and the bus stop waiting area by a short distance when possible
- Remove the return phone number attached to the phone
- Limit the phone to outward calls only

Police Call Box

Police call boxes for transit systems are typically placed in rail stations or at large bus terminals. Providing call boxes at bus stops aids in establishing a safe environment, especially at stops that are less patronized or are located in suburban and rural areas.

Call boxes are an alternative to public telephones. They require less maintenance and do not encourage loitering by non-bus patrons. Police response is improved as call boxes may be geographically identified instantly in the event of an emergency.

Call boxes must not obstruct access to the stop and must be suitable for users with hearing impairments and those using a wheelchair.



Example of a police call box.

Source: Greater Cleveland Regional Transit Authority Police, <http://www.gcrtc.org/crimepre.asp>

³⁹ Transit Cooperative Research Program (TCRP) Report 19, 1996.



Identifying a Bus Stop by People with Visual Impairments

For people with visual disabilities to distinguish a bus stop from other street furniture, unique features should be incorporated into the design of each bus stop. Stops that have shelters are more readily identifiable due to the unique features of the shelter. However, bus stops that are identified only with a flag pole or that have the flag mounted on a utility pole can be difficult to identify. To address this issue, a pole design that is unique to bus stops should be provided at all locations. For example, the pole may be square with holes running down its length. If a unique pole is provided, the transit agency should educate customers who have visual impairments about this feature.

Maintenance of Bus Stops and Shelters

Maintenance is crucial to establishing and maintaining a barrier free bus stop environment. Trash and broken panel glass can reduce accessibility to a stop by obstructing the path of travel. Additionally, a poorly maintained stop presents an unfavorable image of the agency and may lead to crime. Stops left dirty or shelters left broken create unsafe conditions, sending a message that no one is in control of the stop and is thus open to crime.⁴⁰

Bus stop maintenance can be costly and time-consuming. Working agreements with local businesses or commercial centers can reduce the financial responsibilities of the transit agency or public works department. For stops next to convenience stores, the transit or public works agency should try to obtain a working agreement with the local store or businesses to provide trash removal and general maintenance at the bus stop. This should include snow removal.

Adopt-a-Stop programs are an effective way to maintain bus stops and provide informal community surveillance. King County Metro in Seattle, Washington, administers an Adopt-a-Stop program for maintaining bus stops and shelters. The agency installs the trash can at the stop and provides liners to the local program participant. The individual keeps the stop clean and empties the trash can in exchange for a monthly pass. The program has experienced success with the participation of several hundred individuals.⁴¹

Tri-Met in Portland, Oregon compensates its Adopt-a-Stop participants with ten bus tickets per month for maintaining their stops. More than 800 bus stops within Tri-Met's service area have been adopted, and litter reduced by 80 percent through the program.⁴² Tri-Met outlines their maintenance procedures in their Bus Stop Guidelines 2002, which is reproduced in Appendix B.

Maintenance requirements and resistance to vandalism are important considerations in the selection of an appropriate transit shelter. Most shelters are designed to minimize both of these concerns and

⁴⁰ Loukaitou-Sideris, Anastasia, *Hot Spots of Bus Stop Crime: the Importance of Environmental Attributes*.

⁴¹ Nelson/Nygaard, Interview with Ross Hudson, King County Metro.

⁴² Volinski, Joel and Tucker, Lisa E, *Safer Stops for Vulnerable Customers* 2003.

Adopt-a-Stop programs are an effective way to maintain bus stops and provide informal community surveillance. Participation can be high if incentives are given, such as bus passes.



The glass panels of this bus shelter are raised above the ground to accommodate cleaning, but not so high as to create a problem for white cane users. Picture taken in Toronto, Canada.

Source: SUNY Buffalo

To ensure regular maintenance, a database can be created to track the condition of the facilities.

servicing costs should therefore be minimal.⁴³ To enhance ventilation and to reduce the clutter that can accumulate inside a shelter, a 6-inch (152 millimeter) clearance between the ground and the bottom of the panels is standard in fully enclosed shelters.⁴⁴

To ensure regular maintenance, a database containing maintenance schedules can be created to track the condition of the facilities, including pavement surface conditions; age of the facilities; history of damage; and condition of shelter, benches, or other transit amenities. This information can be collected during the bus stop assessment. The maintenance database can be linked as a subsection of the bus stop inventory database.



Although snow has been removed from the entrance to the shelter and the bus landing pad, this bus stop in Toronto, Canada appears to be the collection area for the plowed snow. This conveys a poor message about the value of the bus stop and shelter. Additionally, the restaurant sign obstructs the sight lines of a wheelchair user.

Source: SUNY Buffalo

⁴³ British Columbia Transit Municipal Systems Program.
⁴⁴ Transit Cooperative Research Program (TCRP) Report 19, 1996.

KEY PLAYERS AND AGENCY COORDINATION

Since bus stops are located on public property, several players are involved in construction, improvements and maintenance. Therefore, partnerships between the transit agency, the public and municipal departments are valuable in providing accessible and safe bus stops.

Generally, transit agencies can benefit from partnerships with the following for bus stop improvements:

- Public Works departments
- City/Municipal offices
- Disability, paratransit offices and advocacy groups
- Businesses and developers
- General public

Partnerships with the public are helpful in maintaining stop accessibility. Through programs such as the previously mentioned Adopt-a-Stop, the public can assist in the maintenance of the bus stop by agreeing to pick up litter, clean the stop amenities and report any items needing repair. Tri-Met in Portland, Oregon, compensates individuals in their Adopt-a-Stop program with gloves, cleaning supplies and a steady supply of bus tickets. These types of partnerships are also successful with businesses and developers.⁴⁵

Examples of interagency coordination are provided in Appendix C.



⁴⁵ Tri-Met, *Bus Stop Guidelines* 2002.



Interdepartmental Collaboration

In addition to cooperating with municipal offices and agencies, implementing bus stop improvements is better facilitated by strong organization within the transit agency. An effective example from Tri-Met is provided in Appendix C.

Bus operators are often well-informed about safe locations for pulling over a bus, and should be consulted by planners responsible for bus stop design and location. Bus operators could then pull the bus over easily and serve customers with disabilities more effectively.

DRIVER TRAINING AND SUPPORT

Effective driver training can go a long way in providing accessible and safe service. Training programs may include:⁴⁶

- Sensitivity and awareness training for all transit personnel who come into contact with the public
- Discussion of different causes and characteristics of mobility, hearing, visual and cognitive disabilities
- Demonstration and hands-on experience with any technologies used, such as wheelchairs, hearing aids, white canes, guide dogs and assistive listening devices. Driver sensitivity classes can include the use of opaque glasses to help increase driver awareness and sensitivity towards people with visual impairments
- Training on the fundamentals of communication with persons with hearing impairments and some basic sign language
- Training on orientating visually impaired persons. The operator needs to give explicit directions when people with visual impairments are looking for a vacant seat or departing the vehicle
- Training on safety concerns related to loading and unloading wheeled mobility device users at bus stops

Reducing Bus Operator Tasks

Bus operators are responsible for many tasks besides driving. The introduction of new technology can help free up time for bus drivers to help patrons with disabilities. According to the ADA, drivers are required to announce major intersections and other specific bus stops, operate wheelchair lifts, assist passengers boarding the lift or ramp and secure wheelchairs and scooters. As part of their operator responsibilities, they must give schedule information, handle any difficult passenger situations and monitor the fare box. These responsibilities are in addition to negotiating traffic, making transfers, staying on schedule, and changing destination signs. Some of the tasks mentioned above could be replaced by technology, such as automatic changing of destination signs and automated intersection announcements.⁴⁷



The ADA requires drivers to announce major intersections and other specific bus stops, operate wheelchair lifts, assist passengers boarding the lift or ramp and secure wheelchairs and scooters.

⁴⁶ Hunter-Zaworski, Katharine M. and Hron, Martha, *Improving Bus Accessibility Systems for Persons with Sensory and Cognitive Impairments* 1993.

⁴⁷ Ibid.



This photo illustrates how guidance lines can be incorporated at a stop (*note: in this U.K. example, the bus travels on the other side of the street, but the guidance line principle can be applied in a U.S. context*).

Source: University College London.
<http://www.cts.ucl.ac.uk/arg/projects/excalib1.htm>

Cooperation Between Drivers and Bus Stop Planners

Pulling flush to the curb at a bus stop can be a challenging task for bus drivers. One option to assist drivers in pulling to the curb is painting a guidance line in the roadway to help the driver maintain the proper approach angle to position the bus parallel to the curb. The EXCALIBUR Project in London experiments with guidance lines at a prototype bus stop. The picture on the left shows an EXCALIBUR bus stop with guidance lines and bus cage that are color separated from the rest of the road.⁴⁸

Automated docking systems are another form of technology that can be used to help the driver pull in parallel at a bus stop to better assist boarding and alighting. Automated precision bus docking allows a bus to consistently pull up to a bus stop at precisely the desired distance to the curb, using a magnetic marker or laser guidance system. A discussion of these technologies can be found in the Technology Section.

⁴⁸ Tyler, Nick, Caiaffa Martha, *Design of Fully Accessible Bus Stops Infrastructure Elements for Buses and Drivers* Centre for Transport Studies, University College London.

TECHNOLOGY AND PRODUCT LINKS

Innovations in transit and wayfinding technology provide improved accessibility and safety for all users of bus systems. These include:

- Talking Signs
- Automated Docking Systems
- Side Collision Warning Systems
- NextBus
- i-Stop

Talking Signs® Technology

Remote infrared audible signs, or RIAS, allow people who are print disabled to directly know what and where objects are located. Unlike Braille, raised letters, or voice signs which passively label a location or give instructions to a specific goal, the remote signage technology developed at the Smith-Kettlewell Eye Research Institute (Talking Signs®) provides a repeating, directionally selective voice message which originates at the sign and is transmitted by infrared light to a hand-held receiver some distance away. To learn more about the technology, visit the Smith-Kettlewell Eye Research Institute website located at <http://www.ski.org/Rehab/WCrandall/introts.html>. The website contains reports detailing Talking Signs® research and tests.

Automated Docking Systems

Automated precision bus docking allows a bus to consistently pull up to a bus stop at precisely the desired distance to the curb, using a magnetic marker or laser guidance system.

The California Partners for Advanced Transit and Highways (PATH) at the University of California, Berkeley tested their automated precision bus docking system at Houston Metro. Their technology utilized magnetic markers onto which the bus could automatically latch and perform either fully automated or semi-automated docking. Their demonstration showed that automated docking exceeded human performance in precision and consistency. Potential applications of the PATH magnetic marker guidance system for bus operations include docking, automated bus daily maintenance, and “Bus Rapid Transit.”⁴⁹

⁴⁹ Partners for Advanced Transit and Highways (PATH). *Precision Docking System Demonstration at Houston*. Intellimotion, Vol. 7, No. 3. 1998.





Carnegie Mellon University in association with Université Blaise-Pascal developed a multiple sensor fusion for detecting the location of curbs, walls, and barriers. The researchers utilized a laser line striper, a vehicle state estimator, a video camera, and a laser scanner to detect the object at one location, track it alongside the vehicle, and search for it in front of the vehicle. The study showed that data from a laser line striper fused with vehicle state estimation, video image, and object detection gave reliable measurements of continuous objects alongside the vehicle. These systems can provide the driver with a higher degree of control and can prevent collisions.⁵⁰

For more information on both the systems, refer to the following websites:

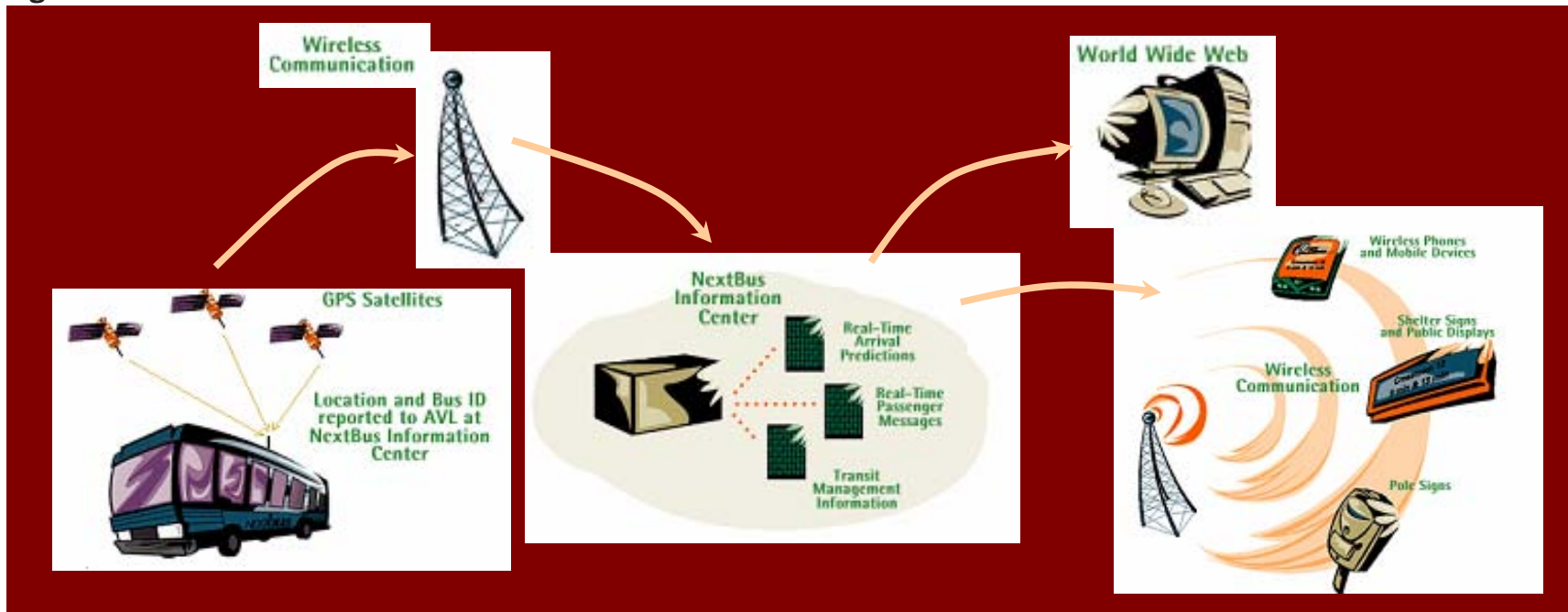
- PATH: <http://www.path.berkeley.edu/PATH/Intellimotion/intel73.pdf>
- Robotics Institute: http://www.ri.cmu.edu/pub_files/pub3/aufriere_romuald_2003_1/aufriere_romuald_2003_1.pdf

⁵⁰ Aufrère, Romuald, Mertz, Christoph, and Thorpe, Charles. Multiple Sensor Fusion for Detecting Location of Curbs, Walls, and Barriers. Proceedings of the IEEE Intelligent Vehicles Symposium (IV2003). 2003.

NextBus

NextBus uses Global Positioning System (GPS) tracking satellites to provide vehicle arrival information and real-time maps, not just bus schedules, to passengers and managers of public transit, shuttles, and trains. The flow of information is diagrammed in Figure 2.

Figure 2. NextBus Information Flow



Source: AC Transit

NextBus information provides actual arrival information, updated at regular intervals to account for traffic variations, breakdowns, and other day-to-day problems faced by any transit provider. The information displays can be installed in bus stop shelters as shown in Figure 3.

Figure 3. Bus Information Display



Source: AC Transit

Technology is now available that provides information to passengers through an audio broadcast, which may provide route or “next-bus” information. This information may be accessed by all passengers by pushing a button on the stop ID pole or may be limited to passengers holding a coded transmitter. This technology should also be combined with a visual display of route information to be accessible to all transit users.

For more information refer to the following website: www.nextbus.com.

i-Stops

i-Stops are solar-powered bus-stop illumination systems featuring a flashing beacon that notifies bus drivers of a stop request, overhead security lighting and an illuminated transit timetable. The i-Stops are self-contained with solar-charging during the day, and are activated by bus patrons after dark with touch switches. i-STOPS are commonly utilized at stops located in less developed areas with minimal lighting or fast moving traffic, mainly located in suburban and rural areas. Options to activate i-Stops with sensors instead of touch switches provide a better alternative for people with visual impairments.

For more information refer to the following website: <http://transitlights.com>.

Bus Stop Shelter Product Links

A variety of transit shelter types are readily available. The following are some of the companies that specialize in bus stop furniture and shelters:

- **JCDecaux**
 - ✧ Products: Street furniture including benches, bus shelters and advertising panels.
 - ✧ Website: <http://www.jcdecaux.co.uk/city/design>
- **Cemusa**
 - ✧ Products: Street furniture including benches, bus shelters, kiosks and trash receptacles.
 - ✧ Website: <http://www.cemusa.com>
- **Tolar Manufacturing Company Inc**
 - ✧ Products: Benches, bus shelters and kiosks and trash receptacles.
 - ✧ Website: <http://www.tolarmfg.com/product.htm>
- **Daytech MFG. LTD.**
 - ✧ Products: Benches, bus shelters, kiosks and map and schedule frames.
 - ✧ Website: <http://www.daytechlimited.com>



Example of an i-Stop.

Source: Carmanah, <http://www.transitlights.com/content/products/i-STOP/default.aspx>



- **Carmanah**
 - ✧ Products: Solar powered bus shelter, solar powered bus stop and bus signaling device.
 - ✧ Website: <http://www.transitlights.com/content/products/Default.aspx>
- **Simme LLC**
 - ✧ Products: Bus stop seating
 - ✧ Website: <http://simmeseat.com>
- **Sepco Plc**
 - ✧ Products: Solar powered bus shelters, stops, flags and advertising
 - ✧ Website: <http://www.sepcopl.com>

URBAN AND RURAL BUS STOPS⁵¹

The design and accessibility of urban and rural bus stops should reflect differences in demographics, density, and land use. Urban areas⁵² are more likely to have continuous sidewalks and high transit ridership compared to rural areas.⁵³ Since rural areas and urban clusters⁵⁴ have proportions of people with disabilities that are comparable to urbanized areas (refer to Figure 4), ensuring that the bus stop is accessible and safe even if continuous sidewalks are not available, is equally important.

Population with Disabilities in Urban and Rural Areas

Census data show that the percentage difference between populations with disabilities living in urban, suburban or rural areas is minimal. Applying accessibility improvements to bus stops is therefore equally valuable in rural areas as it is in suburban and urban areas. Refer to the Creating Accessible and Safe Bus Stops section for rural bus stop design guidelines.

Figure 4 shows the 2000 Census distribution of people in urban and rural areas. Approximately 10.9 million (20 percent) of the almost 55 million rural Americans aged five or older have a disability, while urban clusters have the highest proportion of the population with a disability, over 21 percent. These two categories are often combined by transportation authorities into a broader definition of rural. In this regard, there are about 89 million residents living in rural transportation areas, 16.5 million (20 percent) of whom have a disability.



⁵¹ Research and Training Center on Disability in Rural Communities, the University of Montana Rural Institute, *Update on the Demography of Rural Disability Part One: Rural and Urban 2005*.

⁵² Urban: Territory, population and housing units located within urbanized areas and urban clusters.

⁵³ Rural areas: Territory, population, and housing units located outside of urbanized areas or urban clusters. Rural areas have fewer than 2,500 people or areas where people live in open country.

⁵⁴ Urban Cluster: A densely settled area with a census population of 2,500 to 49,999.



A rural bus stop in Willows, California situated on an unpaved area. The stop is located a considerable distance away from the road, requiring either the patron to walk to the road's edge or the bus to pull off the road.

Source: G. Araki www.the-bus-stops-here.org.



This bus stop in Missoula, Montana is not accessible. It lacks a bus landing pad and accessible path, forcing riders to wait on the road. Additionally, the slope of wheelchair ramp from the bus to the ground will be too steep for wheelchair users to board the bus. Furthermore, placing the bus stop pole in landscaping off the side of the road makes it difficult for a user with visual impairments to locate the stop.

Source: Alexandra Enders, University of Montana

Figure 4. Disability Demographics in Urban and Rural America

	Total population (millions)	Civilian, non-institutionalized population, 5 years and older		
		Total number	Number with a disability	Percent with a disability
United States	281.5	257.2	49.7	19.3%
Urban	222.3	202.5	38.9	19.2%
Urbanized areas*	192.3	175.8	33.2	18.9%
Urban clusters	30.0	26.7	5.7	21.3%
Rural	59.0	54.6	10.9	19.9%
Rural Transit (Rural + Urban Clusters)	89.0	81.3	16.5	20.3%

* Urbanized area: A densely-settled area with a Census population of at least 50,000. A typical urbanized area has more than 500 people per square mile and consists of all or part of one or more incorporated places, such as towns.

Rural Bus Stops⁵⁵

In rural and isolated suburban areas, it is not uncommon to have paved roads with open ditches along the sides to channel storm water. Some of these areas have sidewalks, but most do not, and pedestrians are required to walk on the shoulder of the road. The shoulder often has a steep slope and is comprised of loose material such as gravel and dirt.

Municipalities typically have capital works programs to replace the open ditches with storm sewers. Given the capital cost of such an upgrading, the elimination of ditches and the provision of sidewalks will be a long-term objective in many instances. Transit riders, in the interim, have to board buses without the benefit of a curb to lift them closer to the first step of the bus. Additionally, transit passengers have to get on and off a bus on a gravel or dirt surface. This boarding and unloading situation is very difficult for older adults and especially for those using wheelchairs or other mobility devices.

To best accommodate rural and suburban transit users with disabilities, installing a concrete or asphalt pad on the shoulder of the road is a possible solution to create an accessible bus stop. The pad must be elevated 6 inches (150 millimeters) above road grade for both safety and accessibility purposes. The curb cut between the pad and the road grade must follow the ADA guidelines. Although the elevated pad creates grade changes, it is a preferred scenario to differentiate between vehicle and pedestrian rights-of-way, increasing pedestrian safety. The pad must follow regulations given in the Bus Stop Platforms and Bus Landing Pads section.

⁵⁵ BC Transit Municipal Systems Program, *Design Guidelines for Accessible Bus Stops*.

APPENDICES



APPENDIX A. QUICK BUS STOP CHECKLIST

QUICK BUS STOP CHECKLIST

<i>Route Name:</i>	<i>Location:</i>	<i>Weather Conditions:</i>	<i>Stop No.:</i>
--------------------	------------------	----------------------------	------------------

PART A: IDENTIFICATION/LOCATION							
A1	Street Name:						
A2	Nearest Cross Street (street name or landmark if mid-block):						
A3	Bus Route Direction:						
	<table border="1"> <tr> <td>North Bound <input type="checkbox"/></td> <td>South Bound <input type="checkbox"/></td> <td>More than one direction <input type="checkbox"/></td> </tr> <tr> <td>East Bound <input type="checkbox"/></td> <td>West Bound <input type="checkbox"/></td> <td></td> </tr> </table>	North Bound <input type="checkbox"/>	South Bound <input type="checkbox"/>	More than one direction <input type="checkbox"/>	East Bound <input type="checkbox"/>	West Bound <input type="checkbox"/>	
	North Bound <input type="checkbox"/>	South Bound <input type="checkbox"/>	More than one direction <input type="checkbox"/>				
East Bound <input type="checkbox"/>	West Bound <input type="checkbox"/>						
A4	Where is the bus stop positioned in relation to the nearest intersection?						
	Nearside (Before the bus crosses the intersection)	<input type="checkbox"/>					
	Far Side (After the bus crosses the intersection)	<input type="checkbox"/>					
	Mid-block or not near an intersection	<input type="checkbox"/>					
	Freeway bus pad	<input type="checkbox"/>					
	N/A	<input type="checkbox"/>					
A5	Distance from bus stop pole to curb in feet:						
A6	Adjacent property address or name of business (only if readily visible):						

<i>Date</i>	<i>Time:</i>	<i>Surveyor:</i>
-------------	--------------	------------------

QUICK BUS STOP CHECKLIST

<i>Route Name:</i>	<i>Location:</i>	<i>Weather Conditions:</i>	<i>Stop No.:</i>
--------------------	------------------	----------------------------	------------------

PART B: Landing Area Assessment

B1	Is there a landing area at least 5 feet wide and 8 feet deep adjacent to the curb/street?	Yes <input type="checkbox"/>	No <input type="checkbox"/>		
B2	Where is the landing area positioned in relation to the curb/street?				
	Below street level (low ground or shoulder) <input type="checkbox"/>	Shoulder <input type="checkbox"/>	Other (specify): <input type="checkbox"/>		
	Adjacent <input type="checkbox"/>				
Sidewalk <input type="checkbox"/>	Bus Bulb <input type="checkbox"/>	Off-Road/No sidewalk <input type="checkbox"/>			
B3	What is the material of the landing area?				
	Asphalt <input type="checkbox"/>	Dirt <input type="checkbox"/>	Gravel <input type="checkbox"/>	Other (specify): <input type="checkbox"/>	
	Concrete <input type="checkbox"/>	Grass <input type="checkbox"/>	Pavers <input type="checkbox"/>		
B4	Are there problems with the landing area surface?			Yes <input type="checkbox"/>	No <input type="checkbox"/>
	<i>If YES, rank resulting accessibility potential:</i>				
		Not Accessible	Minimally Accessible	Accessible	
	Uneven	<input type="checkbox"/>	<input type="checkbox"/>	<input type="checkbox"/>	
	Slopes up from the street	<input type="checkbox"/>	<input type="checkbox"/>	<input type="checkbox"/>	
	Slopes down from the street	<input type="checkbox"/>	<input type="checkbox"/>	<input type="checkbox"/>	
	Requires stepping over drain inlet	<input type="checkbox"/>	<input type="checkbox"/>	<input type="checkbox"/>	
Other (Specify)	<input type="checkbox"/>	<input type="checkbox"/>	<input type="checkbox"/>		
B5	Are there any obstacles that would limit the mobility of a wheelchair (trash receptacle, newspaper boxes, landscaping, other)?			Yes <input type="checkbox"/>	No <input type="checkbox"/>
	<i>If YES, describe obstruction:</i>				

<i>Date</i>	<i>Time:</i>	<i>Surveyor:</i>
-------------	--------------	------------------

QUICK BUS STOP CHECKLIST

<i>Route Name:</i>	<i>Location:</i>	<i>Weather Conditions:</i>	<i>Stop No.:</i>
--------------------	------------------	----------------------------	------------------

B6	Additional landing area comments:
-----------	-----------------------------------

PART C: PEDESTRIAN COMFORT AMENITIES

Section C-1: Shelters (move to Section C-2 if there is no shelter)

C1	What are the approximate dimensions (width, height and depth in feet) of the interior standing area?							
	Width:							
	Height:							
	Depth:							
C2	Could a person using a wheelchair maneuver into the shelter?	Yes <input type="checkbox"/> No <input type="checkbox"/>						
C3	Could a person using a wheelchair fit completely under the shelter (minimum space of a common mobility device is 30 in. by 48 in. (760 mm by 1200mm))?	Yes <input type="checkbox"/> No <input type="checkbox"/>						
C4	What is the distance of the front of the shelter from the curb in feet?							
	<table style="width: 100%; border: none;"> <tr> <td style="border: none;">0 - 2' <input type="checkbox"/></td> <td style="border: none;">2' - 4' <input type="checkbox"/></td> <td style="border: none;">4' - 6' <input type="checkbox"/></td> <td style="border: none;">6' - 8' <input type="checkbox"/></td> <td style="border: none;">8' - 10' <input type="checkbox"/></td> <td style="border: none;">>10' <input type="checkbox"/></td> </tr> </table>	0 - 2' <input type="checkbox"/>	2' - 4' <input type="checkbox"/>	4' - 6' <input type="checkbox"/>	6' - 8' <input type="checkbox"/>	8' - 10' <input type="checkbox"/>	>10' <input type="checkbox"/>	
0 - 2' <input type="checkbox"/>	2' - 4' <input type="checkbox"/>	4' - 6' <input type="checkbox"/>	6' - 8' <input type="checkbox"/>	8' - 10' <input type="checkbox"/>	>10' <input type="checkbox"/>			
C5	Additional shelter comments:							

Section C-2: Seating Assessment (move to Part D if there is no seating)

C6	What is the type of seating available?	
	Bench inside shelter – <i>skip to question C8</i>	<input type="checkbox"/>
	Freestanding bench	<input type="checkbox"/>
	Fold down bench	<input type="checkbox"/>
	Leaning bench	<input type="checkbox"/>
	Other (specify):	<input type="checkbox"/>

<i>Date</i>	<i>Time:</i>	<i>Surveyor:</i>
-------------	--------------	------------------

QUICK BUS STOP CHECKLIST

<i>Route Name:</i>	<i>Location:</i>	<i>Weather Conditions:</i>	<i>Stop No.:</i>
--------------------	------------------	----------------------------	------------------

C7	If not inside shelter, what is the distance of the seating from the curb in feet?					
	<table style="width: 100%; border-collapse: collapse;"> <tr> <td style="width: 15%; text-align: center;">0 - 2' <input type="checkbox"/></td> <td style="width: 15%; text-align: center;">2' - 4' <input type="checkbox"/></td> <td style="width: 15%; text-align: center;">4' - 6' <input type="checkbox"/></td> <td style="width: 15%; text-align: center;">6' - 8' <input type="checkbox"/></td> <td style="width: 15%; text-align: center;">8' - 10' <input type="checkbox"/></td> <td style="width: 15%; text-align: center;">>10' <input type="checkbox"/></td> </tr> </table>	0 - 2' <input type="checkbox"/>	2' - 4' <input type="checkbox"/>	4' - 6' <input type="checkbox"/>	6' - 8' <input type="checkbox"/>	8' - 10' <input type="checkbox"/>
0 - 2' <input type="checkbox"/>	2' - 4' <input type="checkbox"/>	4' - 6' <input type="checkbox"/>	6' - 8' <input type="checkbox"/>	8' - 10' <input type="checkbox"/>	>10' <input type="checkbox"/>	
C8	Rank the condition of the seating:					
	<table style="width: 100%; border-collapse: collapse;"> <tr> <td style="width: 15%; text-align: center;">1 <input type="checkbox"/></td> <td style="width: 15%; text-align: center;">2 <input type="checkbox"/></td> <td style="width: 15%; text-align: center;">3 <input type="checkbox"/></td> <td style="width: 15%; text-align: center;">4 <input type="checkbox"/></td> <td style="width: 15%; text-align: center;">5 <input type="checkbox"/></td> </tr> </table> <p style="font-size: small; margin-top: 5px;"> <i>1=hazardous – broken, someone could get hurt from normal use</i> <i>2=in poor shape though not hazardous</i> <i>3=fair – needs repainting, needs cosmetic attention,, protruding but not hazardous bolts</i> <i>4=good – not perfect but no immediate repair need</i> <i>5=cosmetically excellent; new</i> </p>	1 <input type="checkbox"/>	2 <input type="checkbox"/>	3 <input type="checkbox"/>	4 <input type="checkbox"/>	5 <input type="checkbox"/>
1 <input type="checkbox"/>	2 <input type="checkbox"/>	3 <input type="checkbox"/>	4 <input type="checkbox"/>	5 <input type="checkbox"/>		
C9	Additional seating comments:					

PART D: Information Features

D1	Is there a bus stop sign?	Yes	No
	<i>If NO, move to question D5.</i>	<input type="checkbox"/>	<input type="checkbox"/>
D2	Are bus routes indicated on the bus stop sign?	Yes	No
	<i>If YES, what routes?</i>	<input type="checkbox"/>	<input type="checkbox"/>
D3	How is the sign installed?		
	On its own pole	<input type="checkbox"/>	
	On a building	<input type="checkbox"/>	
	On a utility pole	<input type="checkbox"/>	
	On a shelter	<input type="checkbox"/>	
	Other (specify):	<input type="checkbox"/>	

<i>Date</i>	<i>Time:</i>	<i>Surveyor:</i>
-------------	--------------	------------------

QUICK BUS STOP CHECKLIST

<i>Route Name:</i>	<i>Location:</i>	<i>Weather Conditions:</i>	<i>Stop No.:</i>
--------------------	------------------	----------------------------	------------------

D4	Are there problems with the signage?	Yes No <input type="checkbox"/> <input type="checkbox"/>	
	<i>If YES, check all that apply:</i>		
	Sign in poor condition	<input type="checkbox"/>	
	Pole in poor condition	<input type="checkbox"/>	
	Sign position hazardous to pedestrians	<input type="checkbox"/>	
	Sign not permanently mounted	<input type="checkbox"/>	
	Lighting on sign is poor	<input type="checkbox"/>	
	Other (specify):	<input type="checkbox"/>	
D5	Is there route/schedule/map (circle as appropriate) information posted?	Yes No <input type="checkbox"/> <input type="checkbox"/>	
	<i>If NO, skip to Question D8</i>		
D6	Where is the route/schedule/map (circle as appropriate) information posted?		
	On pole under bus stop sign	<input type="checkbox"/>	
	On its own pole	<input type="checkbox"/>	
	On a building	<input type="checkbox"/>	
	On a utility pole	<input type="checkbox"/>	
	On a shelter	<input type="checkbox"/>	
	In a shelter	<input type="checkbox"/>	
	Other (specify):	<input type="checkbox"/>	
D7	Is the information at eye level of a wheelchair user?	Yes No <input type="checkbox"/> <input type="checkbox"/>	
D8	Additional signage & information comments:		

<i>Date</i>	<i>Time:</i>	<i>Surveyor:</i>
-------------	--------------	------------------

QUICK BUS STOP CHECKLIST

<i>Route Name:</i>	<i>Location:</i>	<i>Weather Conditions:</i>	<i>Stop No.:</i>
--------------------	------------------	----------------------------	------------------

PART E: Other Amenities

E1	What other amenities are at the bus stop?	
	Trash receptacle	<input type="checkbox"/>
	Telephone or police call box	<input type="checkbox"/>
	Newspaper boxes	<input type="checkbox"/>
	No other amenities	<input type="checkbox"/>
	Other (specify):	<input type="checkbox"/>
E2	Do any of these amenities block wheelchair access?	Yes No <input type="checkbox"/> <input type="checkbox"/>
	<i>If YES, specify what the amenity is blocking access to:</i>	
	Bus shelter	<input type="checkbox"/>
	Wheelchair seating area	<input type="checkbox"/>
	Bus ingress or egress	<input type="checkbox"/>
	Bus stop information	<input type="checkbox"/>
	Other (specify):	<input type="checkbox"/>

PART F: Traffic and Pedestrian Safety Issues

Section F-1: Traffic and Pedestrian Issues

F1	Where is the bus stop area located?	
	In travel lane	<input type="checkbox"/>
	Bus lane/pull off area	<input type="checkbox"/>
	Paved shoulder	<input type="checkbox"/>
	In right turn only lane	<input type="checkbox"/>
	Unpaved shoulder	<input type="checkbox"/>
	Off street	<input type="checkbox"/>
	"No Parking" portion of street parking lane	<input type="checkbox"/>
	Other (specify):	<input type="checkbox"/>

<i>Date</i>	<i>Time:</i>	<i>Surveyor:</i>
-------------	--------------	------------------

QUICK BUS STOP CHECKLIST

<i>Route Name:</i>	<i>Location:</i>	<i>Weather Conditions:</i>	<i>Stop No.:</i>
--------------------	------------------	----------------------------	------------------

F2	Is the bus stop zone designated as a no parking zone?	Yes No <input type="checkbox"/> <input type="checkbox"/>			
	<i>If YES, indicated by:</i>				
	One "No Parking" sign	<input type="checkbox"/>			
	2 or more "No Parking" signs	<input type="checkbox"/>			
	"Bus Only" sign	<input type="checkbox"/>			
	Painted curb	<input type="checkbox"/>			
	Painted street	<input type="checkbox"/>			
F3	Are cars parked between the landing area and the bus stopping area?	Yes No <input type="checkbox"/> <input type="checkbox"/>			
F4	What is the posted speed limit in MPH?	Not posted <input type="checkbox"/>			
F5	What are the traffic controls at the nearest intersection for the street?				
	Traffic signals	<input type="checkbox"/>			
	Flashing lights	<input type="checkbox"/>			
	Stop/Yield sign	<input type="checkbox"/>			
	None	<input type="checkbox"/>			
	Other (specify):	<input type="checkbox"/>			
F6	How many total lanes are on both sides of the road?				
	1 <input type="checkbox"/>	2 <input type="checkbox"/>	3 <input type="checkbox"/>	4 <input type="checkbox"/>	Other (specify): <input type="checkbox"/>
F7	Are there potential traffic hazards?		Yes No <input type="checkbox"/> <input type="checkbox"/>		
	<i>Yes, check all that apply:</i>				
	The bus stop is just over the crest of a hill		<input type="checkbox"/>		
	The bus stop is just after a curve in the road		<input type="checkbox"/>		
	The bus stop is near an at-grade railroad crossing		<input type="checkbox"/>		
	Waiting passengers are hidden from view of approaching bus		<input type="checkbox"/>		
	A stopped bus straddles the crosswalk		<input type="checkbox"/>		
	Bus stop just before crosswalk		<input type="checkbox"/>		
High speed traffic		<input type="checkbox"/>			

<i>Date</i>	<i>Time:</i>	<i>Surveyor:</i>
-------------	--------------	------------------

QUICK BUS STOP CHECKLIST

<i>Route Name:</i>	<i>Location:</i>	<i>Weather Conditions:</i>	<i>Stop No.:</i>
--------------------	------------------	----------------------------	------------------

	No crosswalk	<input type="checkbox"/>
	Other (specify)	<input type="checkbox"/>
F8	Additional traffic safety comments / recommendations:	

Section F-2: Lighting Assessment (assessment preferably taken in the evening or at night)
Go to Part G if no lighting

F9	What type of lighting is available?	
	Street light	<input type="checkbox"/>
	Shelter lighting	<input type="checkbox"/>
	Outside light on adjacent building	<input type="checkbox"/>
	Other (specify):	<input type="checkbox"/>
F10	Additional comments:	

PART G: Getting to the Bus Stop

G1	How wide is the sidewalk?				
	No sidewalk <input type="checkbox"/>	less than 3' <input type="checkbox"/>	3'-5' <input type="checkbox"/>	5' or greater <input type="checkbox"/>	N/A <input type="checkbox"/>
G2	Rank the condition of the sidewalk:				
	1 <input type="checkbox"/>	2 <input type="checkbox"/>	3 <input type="checkbox"/>	4 <input type="checkbox"/>	5 <input type="checkbox"/>
	<i>1=hazardous – large breaks, cracks, root uplifting, someone could get hurt from normal use or use of a wheelchair would be difficult</i> <i>2=in poor shape though not hazardous – very rough, some root uplifting, cracks, breaks</i> <i>3=fair – minor root uplifting, minor cracks or breaks</i> <i>4=good – not perfect but no immediate repair</i> <i>5=cosmetically excellent; new</i>				

<i>Date</i>	<i>Time:</i>	<i>Surveyor:</i>
-------------	--------------	------------------

QUICK BUS STOP CHECKLIST

<i>Route Name:</i>	<i>Location:</i>	<i>Weather Conditions:</i>	<i>Stop No.:</i>
--------------------	------------------	----------------------------	------------------

G3	Are there physical barriers that constrict the width of the sidewalk within the block on which the bus stop is located?			Yes <input type="checkbox"/>	No <input type="checkbox"/>		
	<i>If YES, what is the narrowest useable width:</i>						
Less than 3' <input type="checkbox"/>		3' or greater <input type="checkbox"/>					
G4	Does the landing pad connect to the sidewalk?				Yes <input type="checkbox"/>	No <input type="checkbox"/>	
	G5 Where is the nearest street crossing opportunity?						
The nearest intersection <input type="checkbox"/>		Mid-block crosswalk <input type="checkbox"/>					
G6	What pedestrian amenities are at the nearest intersection (or other crossing opportunity)?						
	Curb cuts all corners/ both sides <input type="checkbox"/>	Pedestrian crossing signal <input type="checkbox"/>	Traffic light <input type="checkbox"/>				
	Visible crosswalk <input type="checkbox"/>	Audible crosswalk signal <input type="checkbox"/>	Crossing guard assistance <input type="checkbox"/>				
	Curb cuts at some corners/one side <input type="checkbox"/>	Accessible Pedestrian Signal (APS) <input type="checkbox"/>	Tactile warning strip on curb cut <input type="checkbox"/>				
	Other (specify):					<input type="checkbox"/>	

<i>Date</i>	<i>Time:</i>	<i>Surveyor:</i>
-------------	--------------	------------------



APPENDIX B. TRI-MET MAINTENANCE GUIDELINES⁵⁶

Tri-Met in Portland, Oregon, provides guidelines on maintenance activities in their Bus Stop Guidelines 2002 manual. The agency defines a clean stop as free from:

- Debris, including cigarette butts, cups and newspapers
- Foreign substances, including gum, spills and food
- Insects and weeds
- Graffiti (written or etched)
- Unauthorized stickers or posters

Well-maintained stops reflect the following elements:

- Overall passenger facilities are in good repair
- Areas and improvements are in good condition and all repairs are current
- All amenities (shelters, benches, trash receptacles) are properly installed to meet the requirements of city ordinances and Americans with Disabilities Act (ADA)
- Furniture surfaces are in good condition, including no rust, marring or scratches
- Signage, walls, seating and kiosks are in good condition
- Lighting in good working order at all times
- Free from overhanging trees or brush

Tri-Met's guidelines for repair, maintenance and cleaning are detailed below:

- Repairs are performed by both in-house employees and contractors
- Pick up trash and debris within a 15 feet radius of bus stops (blowers shall not be used)
- Remove graffiti, stickers and unauthorized signs and posters
- Power wash all amenities with water. Using a ladder, clean the shelter roof inside and outside with a soft bristled brush until all dirt has been removed. Clean and flush gutters and drain holes of all debris. Clean the shelter frame, bench and windows (inside and outside) until all dirt has been removed using a soft bristled brush and pressure washer. Dry windows with a squeegee so that no smears or

⁵⁶ Tri-Met, 2002.

streaks remain visible. Wipe benches completely dry after cleaning or graffiti removal to allow immediate customer use and to prevent claims for damaged clothing

- Emergency cleaning – all emergency cleanings shall be completed within four hours of notification, except broken glass, which shall be replaced within two hours notification

Tri-Met operates several public-private partnerships in an effort to keep their stops clear of litter and graffiti. Whenever possible, Tri-Met seeks sponsors to assist with the growing trash problem. In most cases, Tri-Met provides the trash receptacle at a particular shelter. The sponsor collects and disposes of the trash as needed. A plaque on the trash can denotes the sponsor's name. Tri-Met maintains the trash can by providing the liner insert, and repairs and repaints (due to graffiti) on an as-needed basis. In addition, they operate their waste disposal routine.

For locations without sponsors, Tri-Met has its own in-house trash collection crew. The crew follows a regular route schedule and also assists in emergency trash pick-up as needed. When a sponsor neglects a trash can due to moving, vacation, etc., the crew assists until another sponsor is found.

Tri-Met partners with Stop Oregon Litter and Vandalism (SOLV) to provide anti-litter and graffiti programs in addition to the regular maintenance routines described above. The SOLV program consists of three major components:

- **Adopt-a-Stop:** A customer agrees to pick up litter, clean the stop amenities and report any items needing repair in exchange for gloves, cleaning supplies and a steady supply of bus tickets.
- **Keep-a-Can:** If a trash can needs to be cleaned at a particular stop, customers or local businesses can sponsor a trash can. Under the program, volunteers agree to empty and provide service for a trash can. In return, Tri-Met will provide an attractive, industrial strength can, liner and soda can recycling container for the stop.
- **First Step Youth Program:** During the summer, SOLV and Tri-Met organize groups of at-risk students to clean up street litter and graffiti, focusing on Tri-Met transit corridors. Tri-Met provides group payment, supervision and transportation.

Tri-Met's bus stop amenities are monitored and have an established shelf life for replacement as a result of accidents, vandalism or general wear over time. Regular maintenance will extend the life of bus shelters and other bus stop features, but their replacement is eventually required. The Capital Improvement (CIP) identifies the following criteria for the replacement of bus stop shelters:

- Condition compromises customer safety
- Exceeds a 15 year life cycle
- Customer security is in some way compromised
- Parts for repair and maintenance are no longer available
- The shelter is not in compliance with ADA

Bus stop signs are similarly replaced if they pose a safety concern for bus riders; they have been damaged or vandalized; they impede movement with ADA guidelines or exceed an 8-year life cycle. Bus stop features may be in good condition beyond their expected life in which case replacement would be deferred. Signs, shelters and other amenities may be upgraded or moved to reflect changes in bus stop use or coordination with other development projects.



APPENDIX C. CASE STUDIES/EXAMPLES OF AGENCY COORDINATION

City of Winnipeg Transit System's Organizational Support for Bus Stops⁵⁷

The City of Winnipeg Transit System in Canada, provides an example of partnerships that have helped implement bus stop improvements and projects. In 1992, the Mayor of Winnipeg established a Task Force to review the status of the paratransit service (referred to as Handi-Transit) and assess emerging technologies to make the fixed-route bus system accessible. Winnipeg Transit decided to convert their fleet to low floor buses - the first three low-floor buses procured were dedicated to Route 10. Improvements were implemented at the bus stops along the route through the following process:

1. The agency enlisted the support of local area city councilors of cities affected by the route
2. Citizens, accompanied by their city councilors, made safety and accessibility assessments along the route
3. With citizen input, the agency developed guidelines for the Route 10 bus stops which became the blueprint for all bus stops in the system
4. The agency continued the audit internally of all 4,500 stops, based on the input obtained through the Route 10 outreach and accessibility improvements. The guidelines serve as an example to staff and private contractors who are implementing the bus stop improvements

Winnipeg City departments have interdepartmental meetings to coordinate future projects. Construction projects are circulated to all the departments (including Transit and Fire) to obtain feedback. The feedback is then incorporated into the project plan. Bus stop improvements and considerations are therefore incorporated into the project before construction begins. The agency has cultivated a good working relationship with Public Works and Planning Departments and is apprised of sidewalk construction projects at least a year in advance.

⁵⁷ NelsonNygaard, Interview with Alex Regiec, City of Winnipeg Transit System, February 28, 2005.

Tri-Met Organizational Support for Bus Stop Management⁵⁸

Tri-Met in Portland, Oregon uses a comprehensive coordinated plan to ensure bus stop accessibility. Many of the elements of this plan could be replicated at other agencies that may not have placed as much focus on bus stop accessibility.

Public-Private Partnerships

An agreement between Tri-Met and the City of Portland has simplified the siting and permitting process for bus shelters and amenities to allow for quicker installation. Tri-Met encourages developing Intergovernmental Agreements and Memoranda of Understanding with municipal departments as they have improved Tri-Met's ability to provide bus stop accessibility and amenity improvements.

Piggybacking on development projects helps in the implementation of bus stop improvements. Depending on the size and nature of the development, Tri-Met may request improvements to adjacent bus stops. If frontage improvements are planned, Tri-Met will request the addition of an ADA landing pad and a rear door landing pad at stops that lack them. If ridership potential exists, the agency may request the developer provide a bus shelter, a bench or other bus stop amenities as warranted. Developers are also required to maintain the stop free of litter and vandalism.

Interdepartmental Coordination

In addition to cooperating with municipal offices and agencies, implementing bus stop improvements is better facilitated by strong organization within the transit agency. *Tri-Met's Bus Stop Guidelines 2002* provides a good description of the responsibilities of each position and department in implementing bus stop improvements.

Tri-Met developed a carriage walk agreement between the Project Planning Department, which oversees bus stop placement and design, and the Bureau of Maintenance. The Agreement coordinates bus stop accessibility improvements (including ADA landing pads and curb ramps), with the city's efforts to upgrade pedestrian infrastructure (such as curb ramps and accessible sidewalks).

⁵⁸ Tri-Met, 2002.

Capital Projects Management Section of the Project Planning Department is responsible for the design and placement of bus stops, including shelter and amenity placement. The section works closely with other Tri-Met departments to provide for the regular maintenance and management of bus stops as well as implementation of bus stop development programs. The following is a brief description of the Section's positions and their responsibilities:

- **Programs Manager:** Responsible for developing and implementing a 5-year Bus Stops Management and Development Plan, which includes negotiating agreements with each major jurisdiction. The Manager is also responsible for coordinating programs and managing the department and program budgets and contracts. The Capital Programs Management Section, including positions matrixed from other departments, report directly to the Programs Manager for bus stop program related activities.
- **Project Planner:** Provides support for field checks and sign placement. Works with the Programs Manager to develop and update the 5-year Bus Stops Management and Development Plan. Provides the lead support for development and coordination of the Streamline Bus Improvement Program and other agency initiatives. Prepares conceptual designs for bus stop improvements and identifies right-of-way permit requirements for new or modified stops.
- **Maintenance Supervisor:** Assesses and manages the cleaning and repair needs and contracts and is responsible for quality control for these efforts.
- **Engineer:** Works closely with all members of the section but also reports to the Project Implementation Department within the Capital Project and Facilities Division. Using Tri-Met and jurisdiction standards, the Engineer prepares design and construction drawings for all bus stop improvements. The Engineer orders utility checks, works with jurisdictions regarding joint construction or traffic managements issues, establishes specifications for procurement contracts of bus stop shelters, signs and other amenities and oversees their installation.
- **Adopt-a-Stop Program Coordinator:** This person monitors partnership agreements for the servicing of bus stops, shelters and trash receptacles and is a contract employee of Stop Oregon Litter and Vandalism (SOLV).
- **Planner/Analyst:** Responsible for building and maintaining Tri-Met's central bus stops database. This position is a significant resource for the planning, analysis and GIS mapping of bus stops and supporting information. The Planner/Analyst uses a Global Positioning System locator device to accurately locate bus stops within the geographic information system files. This person also prepares status and performance reports to track cleaning, repair, response to complaints and work orders.

- **Community Relations Specialist:** Serves as a central point of contact for all external and internal communications pertaining to bus stop related inquiries. This person prepares mailings and notices for bus stop changes and sets up community meetings pertaining to bus stop programs.

The overall responsibility for bus stops management resides with the Bus Stops Section. However, some issues require review and input from a broad cross-section of Tri-Met divisions.

- The **Service Planning Department**, in concert with the **Scheduling Department**, determines routes and the type of services to be provided along the routes. These have direct bearing on the location and design of bus stops.
- The **Field Operations Supervisors** are in the best position to identify bus stop problems and operational concerns that influence bus stop placement. Road Supervisors request bus stop changes based on field observations and as required to accommodate construction projects or events that cause the realignment of service. They also temporarily reroute service when bus stops are affected by construction activities. Road Supervisors also receive customer comments in the course of their surveillance activities. Similarly, Bus Operators also pass on issues that they identify or comments from their bus riders.
- **Maintenance Technicians** in the Facilities Management Department repair and maintain stops and shelters. Maintenance technicians also receive customer comments in the course of their activities, which are managed within their group or passed to the Bus Stops Section.
- The **Information Development Department** of the Marketing and Customer Service Division prepares specifications for signage and information displays and determines locations for other customer information. The **Marketing Department** manages the shelter and bench advertising programs. Individual requests and needs for bus stop changes funnel through the **Customer Service Department** and are recorded in a Customer Service Inquiry database, which is assessed by the Bus Stops Management Section for research and response. Employer outreach efforts conducted by the Marketing Department provide input for program development.
- Tri-Met's **Committee on Accessible Transportation (CAT)** provides a very important consultative role in the management of bus stops. This committee comments on bus stop design guidelines and the development of standard bus stop features (e.g., bus stop shelter design). This perspective helps to assure compliance with the ADA and helps set priorities for bus stop development programs.
- The **Public Art Program** also provides input for integrating art into bus stop design and in identifying opportunities for unique art projects associated with bus stops.
- Other groups are linked through the internal coordination plan and include **Safety, Training and Real Property**.

APPENDIX D: SAMPLE AGREEMENT FOR PRIVATE ROAD BUS STOP PLACEMENT⁵⁹

Pierce Transit in Tacoma, Washington signs a Private Road Bus Stop Placement Use Agreement with owners of private property on which they would like to locate a stop. The agreement is provided below.

PRIVATE ROAD BUS STOP PLACEMENT USE AGREEMENT

THIS USE AGREEMENT, made and entered into in triplicate, this day of 2005, by and between PIERCE COUNTY PUBLIC TRANSPORTATION BENEFIT AREA CORPORATION, a municipal corporation hereinafter called “Pierce Transit” and which represents the ownership and maintenance of a private road, hereinafter called the “Owner”.

WITNESSETH:

WHEREAS, Owner represents the ownership and maintenance of a private road physically located at and further depicted on attached Exhibit “A”; and

WHEREAS, the Owner has requested that Pierce Transit place a bus stop adjacent to the private road and in a location agreed to by the adjacent property owner, and in accordance with the provisions of this agreement; and,

WHEREAS, the parties herein desire to enter into a general use agreement to allow Pierce Transit access to the described private road and allow placement and use of a bus stop by the public to access public transportation services offered from the described location; and,

WHEREAS, Pierce Transit agrees to provide transportation services to this location in consideration of this access and agreement subject to Pierce Transit’s operating requirements; and,

WHEREAS, this agreement does not guarantee the delivery of any public transportation services to the property.

⁵⁹ Nelson\Nygaard, Interview with Tim Renfro, Pierce Transit, March 28, 2005.

NOW, THEREFORE, in consideration of the covenants and agreements the parties hereinafter set forth, Owner does hereby grant unconditional access and use of the private roadway described above including the placement of a bus stop on Owner's property.

1. Premises. The Owner grants to Pierce Transit the right to use that portion of the Owner's premises shown (called the "Premises") for a public bus stop.
2. Usage Rights Granted. Pierce Transit, at its expense, may install signs, paint markings, and other traffic control devices and make other improvements. All other changes shall require the consent of the Owner.
3. Owner's Rights. The Owner reserves the right to make other uses of the Premises that do not interfere with Pierce Transit's use.
4. Term. The term of this Agreement shall be ongoing commencing on this day of 2005. At any time, either Party may terminate this Agreement by giving two (2) months' notice to the other party of its intent to terminate.
5. Access. Pierce Transit may authorize the use of the Owner's driveways, walkways and improved surfaces surrounding the Premises for vehicular and pedestrian access to the Premises.
6. Maintenance. Pierce Transit shall only be responsible for maintenance of markings and improvements that it installs and will not be responsible for any roadway maintenance and repairs at the Premises location. Owner agrees that they have inspected the location of the bus stop and the adjacent roadway and have determined that the location of the bus stop is a safe location and that the roadway is adequate to accommodate public transit vehicles. Further, Owner will hold Pierce Transit harmless from any damage, claims, actions or losses to the roadway connection with the use of the Premises unless a result of Pierce Transit's sole negligence and to the extent permitted by law.
7. Towing of Vehicles. Pierce Transit may order vehicles to be towed away at its own expense and risk. Special consideration, however, shall be provided for vehicles displaying a government-issued "handicapped" license plate or decal.

8. Insurance. Pierce Transit will procure and maintain, for the duration of the Agreement, insurance and/or self-insurance against claims for injuries to persons or damage to property that may arise from or in connection with the use of the Premises.
9. Indemnification/Hold Harmless. Pierce Transit will defend, indemnify and hold harmless the Owner, its officers, officials, employees, and volunteers from and against any and all claims, suits, actions or liabilities for injury or death of any person, or for loss or damage to property, which arises out of the use of Premises or from any activity, work or things done, permitted or suffered by Pierce Transit in or about the Premises, except only such injury or damage as shall have been occasioned by the sole negligence of Owner.
10. Governmental Charges. Pierce Transit shall not be responsible for any taxes, assessments, or governmental charges of any kind that may be levied against the Premises.
11. Termination. Pierce Transit will discontinue its use of the Premises on termination of this Agreement; will remove all signs and structures placed on the Premises by Pierce Transit; will repair any damage to the Premises caused by the removal; and will restore the Premises to as good a condition, less reasonable wear and tear, as existed prior to the execution of this Agreement.
12. Accommodation. The parties agree to make reasonable accommodations with and to work together to resolve problems that may arise from time to time. Upon reasonable advance notice to Pierce Transit and its users, the Owner may secure the Premises on a limited number of dates to allow for construction on surrounding property or special events. The Owner agrees to provide special consideration for vehicles displaying a government-issued “handicapped” license plate or decal.
13. Entire Agreement. This document contains the entire agreement between the parties and supersedes all other statements or understandings between the parties.



APPENDIX E. FIELD TEST LOCATIONS

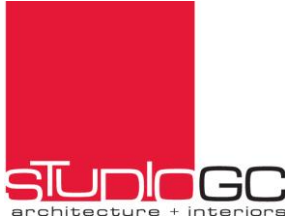
The Bus Stop Checklist was tested in the field with the following transit agencies:

- **AC Transit in Oakland, California**
Robert Del Rosario
Transportation Planner
AC Transit
1600 Franklin Street
Oakland, California 94612
- **Fairfax County Department of Transportation in Fairfax, Virginia**
Denis P. Paddeu
Senior Transportation Specialist
Fairfax County Department of Transportation/Fairfax Connector
12055 Government Center Parkway, Suite 1034
Fairfax, Virginia 22035-5515
- **Marin County Transit District in Marin, California**
Amy Van Doren
Transit Manager
Marin County Transit District
Marin County Civic Center
Room 304
San Rafael, California 94913-4186
- **Niagara Frontier Transportation Authority in Buffalo, New York**
Christopher Cronin
Traffic Data Administrator
Niagara Frontier Transportation Authority
181 Ellicott Street
Buffalo, New York 1420

- **Southeast Transportation Authority in Greenwood Village, Colorado**
Suzanne O’Neill
Transportation Manager
30 South Raritan Street
Denver, Colorado 80223
- **SunLine Transit Agency in Palm Springs**
Eunice Lovi
Director of Planning
SunLine Transit Agency
32-505 Harry Oliver Trail
Thousand Palms, California 92276

APPENDIX F. USEFUL RESOURCES

- ADA Accessibility Guidelines for Buildings and Facilities (ADAAG): <http://www.access-board.gov/adaag/html/adaag.htm>
- Center for People with Disabilities: To determine the accessibility barriers to using bus stops in the City of Boulder for people with disabilities, consumer volunteers researched the reported problems and documented the barriers they found. The barriers found may be applicable to transit systems throughout the U.S. The findings are detailed on their website: <http://www.cpwd-ilc.org/cpwd/ilp/survey05/>.
- Universal Design: IDEA Center, State University of New York at Buffalo; Global Universal Design Educator's Network, <http://www.udeducation.org/>. This site supports educators and students in their teaching and study of universal design. Provides information on universal design and links to resources.



223 West Jackson Boulevard
Suite 1200
Chicago, IL 60606
Phone: 312 253 3400
Fax: 312 253 3401

Memorandum

Date: October 2, 2019

Re: Orland Park Playground Assessment

At the request of Orland Park Parks and Recreation Department, StudioGC reviewed the playgrounds, sports amenities, and other aspects of the majority of the parks in the system. The parks were assessed on the following criteria:

- Security
- Accessibility
- General Conditions

Each category was given a score for the individual element, as applicable. Each amenity was scored on a scale of 1-5. The general concept was as follows:

- **1:** Significant remediation or work needed to bring the project into compliance with either code or general play area standards.
- **2:** Area is in some need of improvement. Disrepair or other concerns are not significantly affecting the ability for the patrons to use the amenity or significantly affecting the play experience.
- **3:** The amenity is meeting commonly accepted standards. There may be some deterioration, but it is within the expectations for the life expectancy of the unit.
- **4:** The amenity exceeds standards and is in exceptional shape or condition in regard to the anticipated life expectancy due to material choices or District maintenance.
- **5:** The amenity far exceeds standards. It was either designed in such a way to provide additional features, provides an inclusive play experience beyond the minimum standard or provides a unique play experience.

It is important to note these are general concepts applied during the assessment. Each criteria and location may have slightly different variables that may swing individual assessment scores.

Security:

The concept of security is a simple one which is intended to convey and provide a safe and secure area for recreational and play activities. The concept of safety is a minimum standard. Any safety concerns have been immediately relayed to the Department staff to rectify. Security is an ongoing and fluid topic for parks. An example of a “three” score would be a park that has some level of visibility from the road, protection from vehicular traffic, and provides a safe

means for the users. If the park provided general lighting to increase the visibility, the park would be rated higher. If the visibility was poor from the roadways or isolated pavilions that encourage after hours use, then the park score would be lowered accordingly.

Accessibility:

The vast majority of the parks were constructed prior to the enactment of the 2010 Accessibility guidelines. It is, therefore, difficult to score parks that are not currently accessible, but met the guidelines at the time they were built. For purposes of this guide we have determined that if the park is in good condition, though not accessible, it will be analyzed based on the applicable code at the time. Therefore, it would be given a “three.” If a park is designed and constructed after 2010 and it meets the accessibility requirements, it will also be given a “three” as that is the minimum standard at the time of construction. If a pre-2010 park appears to meet or exceed the current accessibility standards, it would be regarded as a score higher than “three.” The same is true of a post-2010 park that provides greater opportunity of inclusive play.

Please note, the assessments within this study are general guidelines and impressions of accessibility. It is highly recommended that any park that is post 2010 that does not meet the current requirements have a specific assessment by qualified personnel. This assessment was outside of the scope of this assessment. It is also important to recognize that pre-2010 parks are scored as they are because according to current legislation they are “grandfathered.” There have been indications that this may not be applicable in future and park facilities, but may require to be renovated to meet current accessibility standards regardless of their age upon a complaint by a patron.

The scores are also adjusted based on a concept of “accessibility of” and necessarily “accessibility to.” For example, there are a number of sand pits in the park inventory. Those may have an accessible route to them, but the play element is not accessible itself. Therefore, it would have a lower score.

General Conditions:

Conditions are assessed on the apparent deterioration of the equipment or amenity. The assessment is not based on the age of the unit, though the anticipated useful life is stated in the budgeting document. A new play element that is constructed of exceptional materials that is intended to last far longer than a typical play element would, is given an elevated score. An aged amenity at the end of its useful life would be given a lower score; wear and tear are beginning to impact the patron experience.

All of the parks are well maintained for their age. There has been a clear and well considered effort to extend the useful life of the equipment as long as possible. This is evident in many of the amenities use extending beyond the anticipated replacement dates.

PARK TYPES:

An additional level of classification for the parks generally follows the IPRA guidelines for park classification. A brief description of each is as follows:



Mini Parks: Mini Parks are specialized facilities that serve a concentrated or limited population area, or that serve a specific function or age group. Examples of amenities found in mini parks include playground/tot lot equipment, benches, picnic tables, gazebos, ornamental landscape features, etc. They tend to be less than an acre in size and do not typically have sports fields/courts.

Neighborhood Parks: The Neighborhood Park serves as the primary area for recreational and social activities of the neighborhood. Generally designed with a focus on informal active and passive recreation that serves neighborhood recreation needs, area is provided for recreational activities such as field games, court games, picnicking and playground areas. Parks of this size tend to be between 5 and 10 acres, but depending on amenities, they may vary in size.

Community Parks: Community Parks are diverse in nature, serving a broader purpose than the neighborhood or mini parks. While community parks may include neighborhood park amenities, and do act as neighborhood parks as well, the focus of a community park is on meeting community-based recreation, athletics, and open space needs. These parks may contain significant athletic complexes, aquatic amenities, walking paths, picnic areas and various other active and passive amenities depending upon community needs and site suitability. In some cases, a park with only a single athletic field that provides a venue for community athletic organizations may fall into this category regardless of its small size. Generally, these parks have unique elements or special features that draw patrons from across the service area.

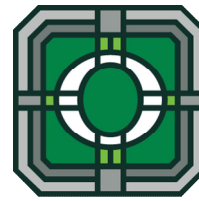
SUMMARY:

In summary, the parks at Orland Park are exceptionally well maintained. There has been a clear effort to extend the park inventory, experiences, and inclusiveness of play. The types and variety of parks are distributed well across the Village. The primary concern facing the Village is the number of parks that are facing low scores due to their age and applicability to the patrons. While there is often a focus on creating new and exciting parks in new areas, there is a renewed focus on rehabilitating and replacing aging, inadequate, and marginally successful parks. Please note that StudioGC recognizes there are additional considerations which include budgets, demographics of surrounding areas, new trends in play, and recreational experiences and guides the determination as to what to replace and when is appropriate to do so.

Sincerely,

Craig S Meadows, AIA
Principal

PARK #	PARK NAME	PARK TYPE	RATED SCORE			
			SECURITY	ACCESSIBILITY	GENERAL CONDITION	SCORE AVERAGE
MINI PARKS						
1	PULTE PARK	Mini	2.00	2.20	2.00	2.07
2	WEDGEWOOD COMMONS	Mini	3.00	1.40	2.29	2.23
3	BROWN PARK	Mini	2.00	2.67	2.38	2.35
4	BILL YOUNG PARK	Mini	1.00	3.25	3.00	2.42
5	PARKVIEW PARK	Mini	3.00	2.00	2.33	2.44
6	ORLAND WOODS	Mini	2.67	2.20	3.00	2.62
7	QUINTANA PARK	Mini	3.00	2.00	3.00	2.67
8	AVENEL PARK	Mini	2.50	3.00	3.00	2.83
9	BRECKENRIDGE PARK	Mini	2.00	3.38	3.27	2.88
10	TAMPIER-MCGINNIS PARK	Mini	3.00	2.83	2.86	2.90
11	GEORGETOWN PARK	Mini	3.00	2.75	3.20	2.98
12	FRONTIER PARK	Mini	3.00	3.14	3.25	3.13
13	CRYSTAL CREEK PARK	Mini	4.00	3.33	2.33	3.22



PARK ASSESSMENT SUMMARY - BY PARK TYPE

VILLAGE OF ORLAND PARK

PARK FACILITY ASSESSMENT

Friday, October 4, 2019

NEIGHBORHOOD PARKS						
14	DISCOVERY PARK	Neighborhood	2.00	2.22	1.83	2.02
15	VILLAGE SQUARE PARK	Neighborhood	2.00	2.00	2.25	2.08
16	MARLEY CREEK PARK	Neighborhood	2.00	2.00	2.58	2.19
17	ISHNALA WOODS PARK	Neighborhood	3.00	1.56	2.07	2.21
18	HERITAGE PARK	Neighborhood	3.00	1.57	2.40	2.32
19	SPRING CREEK ESTATES PARK	Neighborhood	3.00	1.83	2.17	2.33
20	ISHNALA PARK	Neighborhood	2.50	2.13	2.42	2.35
21	WEDGEWOOD ESTATES PARK	Neighborhood	3.00	1.83	2.25	2.36
22	CAMENO REAL PARK	Neighborhood	2.00	2.50	2.73	2.41
23	PERMINAS PARK	Neighborhood	3.00	2.29	2.00	2.43
24	LONG RUN CREEK PARK	Neighborhood	2.00	2.38	2.92	2.43
25	NEWBURY PARK	Neighborhood	3.00	2.00	2.42	2.47
26	MISSION HILLS PARK	Neighborhood	2.50	2.57	2.58	2.55
27	TREETOP PARK	Neighborhood	2.50	2.70	2.46	2.55
28	WLODARSKI PARK	Neighborhood	3.00	2.43	2.42	2.62
29	SARATOGA PARK	Neighborhood	3.00	2.00	3.00	2.67
30	EVERGREEN VIEW PARK	Neighborhood	3.00	2.56	2.67	2.74
31	EMERALD ESTATES PARK	Neighborhood	3.00	2.17	3.08	2.75
32	LAUREL PARK	Neighborhood	3.00	2.57	2.91	2.83
33	MALLARDS LANDING PARK	Neighborhood	3.00	2.88	2.73	2.87
34	EQUESTRIAN PARK	Neighborhood	4.00	2.00	2.73	2.91
35	GRASSLANDS PARK	Neighborhood	3.00	2.89	2.92	2.94
36	HELEN PARK	Neighborhood	3.00	3.08	2.79	2.96
37	SUNNY PINE PARK	Neighborhood	3.00	2.33	3.63	2.99
38	FOUNTAIN HILLS PARK	Neighborhood	3.00	2.89	3.18	3.02
39	COLONIAL PARK	Neighborhood	4.00	2.57	2.50	3.02
40	COUNTRY CLUB ESTATES	Neighborhood	3.50	2.88	2.80	3.06
41	EAGLE RIDGE III PARK	Neighborhood	4.00	3.13	2.83	3.32
42	DEER POINT PARK	Neighborhood	4.00	3.29	2.86	3.38
43	DOGWOOD PARK	Neighborhood	3.00	3.10	4.64	3.58
44	BUNRATTY PARK	Neighborhood	4.00	3.44	3.82	3.75
45	DEER HAVEN PARK	Neighborhood	4.00	3.00	4.36	3.79
46	GREYSTONE PARK	Neighborhood	3.00	3.63	5.00	3.88
47	COLETTE HIGHLANDS PARK	Neighborhood	4.00	3.38	4.36	3.91

LEGEND	DESCRIPTION
0-2.50	Park is in need of upgrades/renovation
2.51 - 2.99	Park has some areas of concern that need to be addressed
3.00-5.00	Park is in good, to exceptional, shape. Minor review of specific issues to address in future renovations

COMMUNITY PARKS						
48	SCHUSSLER PARK	Community	3.50	1.23	1.89	2.21
49	EAGLE RIDGE I PARK	Community	3.00	2.30	2.36	2.55
50	DOOGAN PARK	Community	3.00	2.67	2.87	2.84
51	EAGLE RIDGE II PARK	Community	3.00	3.30	2.31	2.87
52	CACHEY PARK	Community	3.75	2.31	2.83	2.96
53	VETERANS PARK	Community	3.00	2.67	4.06	3.24
54	CENTENNIAL HERTZ PARK	Community	4.00	3.40	3.62	3.67
55	BRENTWOOD PARK	Community	5.00	3.50	3.81	4.10

NAME: AVENEL PARK
ADDRESS: 16400 Avenel Drive Orland Park, IL 60462
PARK TYPE: Mini
EVALUATION YEAR: 2019



PARK MAP:



PARK DATA:

Last Renovated	1999
Park Age:	20
Total Acreage:	0.4
Total Parking Spaces	0

Amenities:

Walking Path
 "Porch" Swings
 Benches

SECURITY COMMENTS:

Score **2.50**

Park security is as to be expected for this size facility. See a few specific areas of note:
 - Rear walking area is not visible from the road
 - No security level of lighting is present
 - Landscaping should be trimmed to promote a reasonable amount of visibility from the road.

ACCESSIBILITY COMMENTS

Score **3.00**

This park fairs well on accessibility.
 - The swing benches do not have an accessible route to them

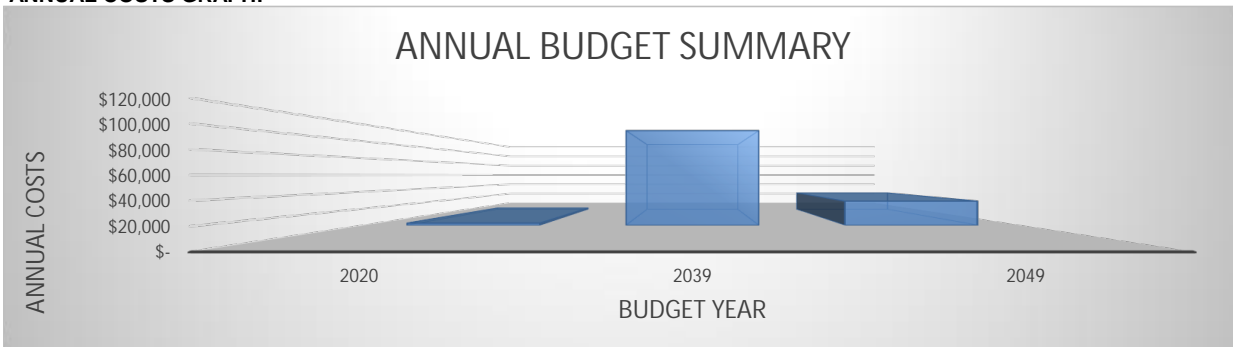
GENERAL CONDITION COMMENTS

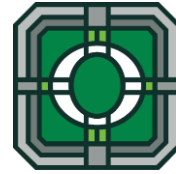
Score **3.00**

The park is in exceptional condition given it's age. The equipment shows deterioration as would be expected. A simple paint refresh is all that is necessary.

Score Average **2.83**

ANNUAL COSTS GRAPH:





COST BY BUDGET YEAR:

AVENEL PARK

Budget Year	Component	Detail	Values	
			Sum of 2019 Replacement Cost	Sum of Escalated Budget
2020	PARK AMENITIES	Benches	\$2,000.00	\$2,130.00
		Trash/Recycling	\$400.00	\$426.00
2020 Total			\$2,400.00	\$2,556.00
2039	SITE COMPONENTS	Concrete Walks	\$32,022.60	\$112,836.29
2039 Total			\$32,022.60	\$112,836.29
2049	SITE COMPONENTS	Landscaping	\$4,356.00	\$28,812.18
2049 Total			\$4,356.00	\$28,812.18
Grand Total			\$38,778.60	\$144,204.46

Description/Life Expectancy		Task	Installed Date	Service Life	Anticipated Replacement Date	General Conditions			Evaluated Condition			Estimated Cost Data - 2019						Comments	
Component	Detail		(year)	(years)	(year)	Security (1-5)	General (1-5)	Accessibility (1-5)	Evaluation Date	Life Expectancy Modifier	Life Expectancy Beyond Evaluation (years remaining)	Budget Year	Qty	Units	Prorate	Unit Cost	2019 Replacement Cost		Escalated Budget
						(0 is lowest)	(0 is lowest)	(0 is lowest)	(year)	%	(0 is lowest)						(As of Evaluation date)		
SITE COMPONENTS						2													
Site Components	Concrete Walks		1999	40	2039			5	2019	0%	0	2039	6,405	sf		\$5.00	\$32,023	\$112,836	
Site Components	Landscaping		1999	50	2049	3	3		2019	0%	0	2049	17,424	sf		\$0.25	\$4,356	\$28,812	
PLAY COMPONENTS																			
PARK AMENITIES																			
Park Amenities	Park Security																		\$0
Park Amenities	Benches		1999	10	2009		3	1	2019	110%	11	2020	2	each		\$1,000.00	\$2,000	\$2,130	
Park Amenities	Trash/Recycling		1999	10	2009		3	3	2019	110%	11	2020	1	each		\$400.00	\$400	\$426	
RECREATION COMPONENTS																			
						2.50	3.00	3.00										\$38,779	\$144,204

NOTES

Evaluation of building conditions focused on the elements likely to be included in the budget for items expected to require replacement or renovation within the next 10 to 15 years. Equipment, materials, or assemblies that are nominal in cost are not included. This is therefore not a comprehensive list but does identify major expenses that are likely to be incurred in the foreseeable future.

Conditions change with time, and this evaluation, along with the funds allocated to cover the associated expenses should be reviewed and revised periodically as the districts' needs evolve. Unanticipated expenses can develop for a number of reasons including accelerated use or changes in use patterns, accident, or deferred general maintenance. Such reviews should include updating baseline costs and dates for the components or assemblies identified in this study.

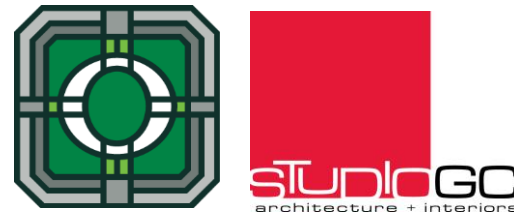
Costs are calculated at 2019 levels and escalated at the following presumed annual rate of inflation:

6.50% per annum

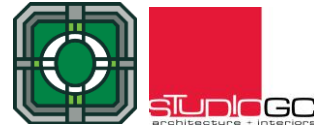
This report is broken up into different categories. The first three are organized by category with like expenses grouped together. The worksheets also covers Mechanical expenses, Electrical expenses, and Plumbing expenses. The last worksheet is organized by the computed year of expense (Budget Year).

Repair/replacement work items do not include A/E Design Fees in the cost.

Total Combined Facilities	
2020	\$2,556
2039	\$112,836
2049	\$28,812
Total:	\$144,204



NAME: BILL YOUNG PARK
ADDRESS: 15251 Huntington Ct, Orland Park, Illinois
PARK TYPE: Mini
EVALUATION YEAR: 2019



PARK MAP:



PARK DATA:

Year Renovated	1996
Park Age:	23
Total Acreage:	0.3
Total Parking Spaces	0

Amenities:

Playground Equipment: Landscape Structures
 Handicap Swing

SECURITY COMMENTS:

Score **1.00**

- Park security is as to be expected for this size facility. See a few specific areas of note and one concern:
- Great visibility from public ways
 - No security level of lighting is present
 - The fence should be replaced with a bollard system to provide protection against run-away cars. It is unclear if the PVC fence is reinforced enough to withstand out of control car. This is the primary reason for the lowered score.
 - Fence should be added along all roadways adjacent to the park where the play areas are within 100 feet of the road.

ACCESSIBILITY COMMENTS

Score **3.25**

- This park has wider accessibility than would be expected for it's age.
- The sand play features are not accessible
 - The PIP tiles are marginally accessible but require additional maintenance to maintain accessibility to equipment.
 - Sidewalks provide a good level of accessibility and are generally free from heaving.
 - Playground equipment will require additional evaluation to determine ADA compliance

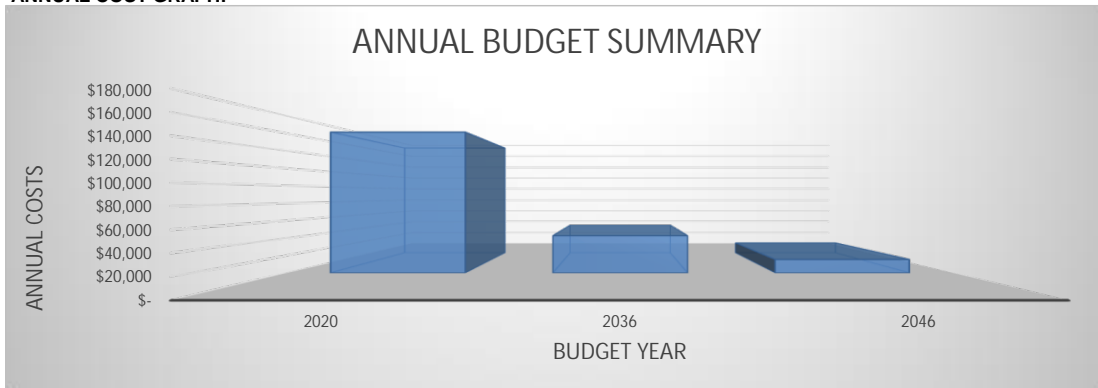
GENERAL CONDITION COMMENTS

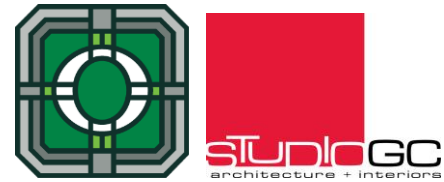
Score **3.00**

- The park is in exceptional condition given it's age. Much of the play equipment has aged well and has only minimal deterioration requiring spot repair.
- The PIP pads are deteriorated and are not stable. This is not unexpected given it is PIP tile system.
 - Sand has migrated into the mulch and is creating some accessibility issues and a general look of disrepair. Please note multiple parks have sand hornets/bees in the sand. Complaints were noted on site from users at multiple parks.

Score Average **2.42**

ANNUAL COST GRAPH:





COST BY BUDGET YEAR:

BILL YOUNG PARK

Budget Year	Component	Detail	Values	
			Sum of 2019 Replacement Cost	Sum of Escalated Budget
2020	PARK AMENITIES	Benches	\$2,000.00	\$2,130.00
		Trash/Recycling	\$400.00	\$426.00
	Play Component	Elevated Structures (2)	\$50,000.00	\$53,250.00
		Ground Equipment	\$2,500.00	\$2,662.50
		Mulch	\$23,712.14	\$25,253.42
	RECREATION COMPONENTS	Fencing	\$73,000.00	\$77,745.00
2020 Total			\$151,612.14	\$161,466.92
2036	SITE COMPONENTS	Concrete Walks	\$3,368.99	\$9,827.49
	Play Component	Edge Restraint		\$32,894.85
2036 Total			\$14,645.75	\$42,722.34
2046	SITE COMPONENTS	Landscaping	\$2,831.40	\$15,503.89
2046 Total			\$2,831.40	\$15,503.89
Grand Total			\$169,089.29	\$219,693.16

Description/Life Expectancy		Task	Installed Date	Service Life	Anticipated Replacement Date	Assessments			Evaluated Condition			Estimated Cost Data - 2019						Comments		
Component	Detail		(year)	(years)	(year)	Security (1-5) (0 is lowest)	General (1-5) (0 is lowest)	Accessibility (1-5) (0 is lowest)	Evaluation Date (year)	Life Expectancy Modifier %	Life Expectancy Beyond Evaluation (years remaining) (0 is lowest)	Budget Year	Qty	Units	Prorate	Unit Cost	2019 Replacement Cost (As of Evaluation date)	Escalated Budget		
SITE COMPONENTS						1														
Site Components	Concrete Walks		1996	40	2036		4	4	2019	0%	0	2036	674	sf		\$5.00	\$3,369	\$9,827		
Site Components	Landscaping		1996	50	2046		3		2019	0%	0	2046	11,326	sf		\$0.25	\$2,831	\$15,504		
PLAY COMPONENTS																				
Play Component	Elevated Structures (2)		1996	15	2011		2	3	2019	55%	8	2020	2	each		\$25,000.00	\$50,000	\$53,250	See Accessibility Chart	
Play Component	Ground Equipment		1996	15	2011		1	3	2019	55%	8	2020	1	each		\$2,500.00	\$2,500	\$2,663	See Accessibility Chart	
Play Component	Mulch		2010	10	2020		3	3	2019	0%	0	2020	4,742	sf		\$5.00	\$23,712	\$25,253		
Play Component	Edge Restraint		1996	40	2036		5		2019	0%	0	2036	297	lf		\$38.00	\$11,277	\$32,895	Plastic Edging	
PARK AMENITIES																				
Park Amenities	Benches		1996	10	2006		3		2019	140%	14	2020	2	each		\$1,000.00	\$2,000	\$2,130		
Park Amenities	Trash/Recycling		1996	10	2006		3		2019	140%	14	2020	1	each		\$400.00	\$400	\$426		
RECREATION COMPONENTS																				
Recreation Components	Fencing		1996	10	2006				2019	140%	14	2020	365	lf		\$200.00	\$73,000	\$77,745		
						1.00	3.00	3.25							\$96,089	\$141,948				

NOTES

Evaluation of building conditions focused on the elements likely to be included in the budget for items expected to require replacement or renovation within the next 10 to 15 years. Equipment, materials, or assemblies that are nominal in cost are not included. This is therefore not a comprehensive list but does identify major expenses that are likely to be incurred in the foreseeable future.

Conditions change with time, and this evaluation, along with the funds allocated to cover the associated expenses should be reviewed and revised periodically as the Department's needs evolve. Unanticipated expenses can develop for a number of reasons including accelerated use or changes in use patterns, accident, or deferred general maintenance. Such reviews should include updating baseline costs and dates for the components or assemblies identified in this study.

Costs are calculated at 2019 levels and escalated at the following presumed annual rate of inflation:

6.50% per annum

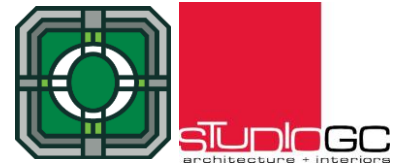
This report is broken up into different categories. The first three are organized by category with like expenses grouped together. The worksheets also covers Mechanical expenses, Electrical expenses, and Plumbing expenses. The last worksheet is organized by the computed year of expense (Budget Year).

Repair/replacement work items do not include A/E Design Fees in the cost.

Total Combined Facilities	
2020	\$161,467
2036	\$42,722
2046	\$15,504
Total:	\$219,693



NAME: BRECKENRIDGE PARK
ADDRESS: 11700 Imperial Lane, Orland Park
PARK TYPE: Mini
EVALUATION YEAR: 2019



PARK MAP:



PARK DATA:

Year Renovated:	2002
Park Age:	17
Total Acreage:	1.4
Total Parking Spaces:	0

Amenities:

Playground Equip:	Burke
Bocce Ball	2
Climbing Wall	
Fishing	
Horseshoes	2
Pavilion	
Grill	

SECURITY COMMENTS:

- Park is visible from surrounding houses.
- It is NOT visible from the public way.
- Security lighting should be considered if law enforcement has concerns.

Score **2.00**

ACCESSIBILITY COMMENTS

- This park is more accessible than would be expected for it's age.
- Bocce and Horseshoe areas are not accessible.
- Sidewalks provide a good level of accessibility and are generally free from heaving but in need of replacement
- Playground equipment will require additional evaluation to determine ADA compliance
- Back pathway, and accessible route to play area, has significant heaving

Score **3.38**

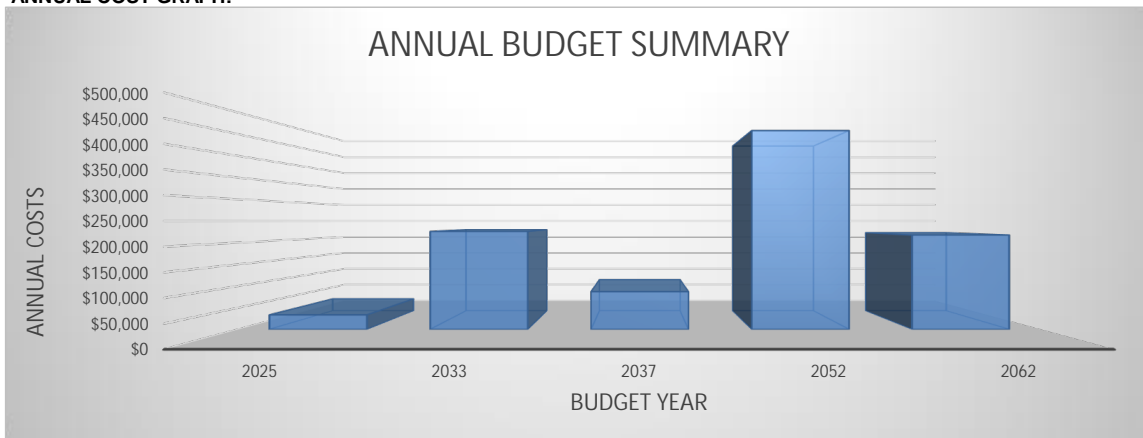
GENERAL CONDITION COMMENTS

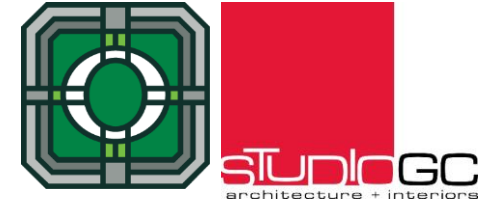
- The park is in exceptional condition given it's age. Much of the play equipment has aged well and has only minimal deterioration requiring spot repair.
- Asphalt walks have deteriorated and are beginning to effect accessibility.
- Artificial grass at climbing wall should be replaced, it is worn.
- Bocce Ball and Horseshoes edging and elements have aged and are deteriorated.

Score **3.27**

Score Average **2.88**

ANNUAL COST GRAPH:





COST BY BUDGET YEAR:

BRECKENRIDGE PARK

Budget Year	Component	Detail	Values	
			Sum of 2019 Replacement Cost	Sum of Escalated Budget
2025	Play Component	Fiber Play Surface	\$23,000.00	\$33,560.27
2025 Total			\$23,000.00	\$33,560.27
2033	PARK AMENITIES	Benches	\$2,000.00	\$4,829.75
		Trash/Recycling	\$400.00	\$965.95
		Drinking Fountain	\$6,500.00	\$15,696.68
	Play Component	Elevated Structures (2)	\$75,000.00	\$181,115.56
		Ground Equipment	\$9,600.00	\$23,182.79
2033 Total			\$93,500.00	\$225,790.74
2037	PARK AMENITIES	Pavilion	\$28,000.00	\$86,986.32
2037 Total			\$28,000.00	\$86,986.32
2052	SITE COMPONENTS	Concrete Walks	\$15,240.00	\$121,764.87
		Concrete Patio	\$28,800.00	\$230,106.85
	Play Component	Edge Restraint	\$13,300.00	\$106,264.62
2052 Total			\$57,340.00	\$458,136.34
2062	SITE COMPONENTS	Landscaping	\$14,500.00	\$217,470.89
2062 Total			\$14,500.00	\$217,470.89
Grand Total			\$216,340.00	\$1,021,944.57

BRECKENRIDGE PARK		11700 Imperial Lane, Orland Park				Assessments			Evaluated Condition			Estimated Cost Data - 2019						Comments	
Description/Life Expectancy		Task	Installed Date	Service Life	Anticipated Replacement Date	Security (1-5)	General (1-5)	Accessibility (1-5)	Evaluation Date	Life Expectancy Modifier	Life Expectancy Beyond Evaluation (years remaining)	Budget Year	Qty	Units	Prorate	Unit Cost	2019 Replacement Cost		Escalated Budget
Component	Detail		(year)	(years)	(year)	(0 is lowest)	(0 is lowest)	(0 is lowest)	(year)	%	(0 is lowest)						(As of Evaluation date)		
SITE COMPONENTS						2													
Site Components	Concrete Walks		2012	40	2052		2	4	2019	0%	0	2052	3,048	sf		\$5.00	\$15,240	\$121,765	
Site Components	Concrete Patio		2012	40	2052		3	3	2019	0%	0	2052	1,600	sf		\$18.00	\$28,800	\$230,107	
Site Components	Landscaping		2012	50	2062		3		2019	0%	0	2062	58,000	sf		\$0.25	\$14,500	\$217,471	
PLAY COMPONENTS																			
Play Component	Elevated Structures (2)		2012	15	2027		3	4	2019	40%	6	2033	3	each		\$25,000.00	\$75,000	\$181,116	See Accessibility Chart
Play Component	Ground Equipment		2012	15	2027		3	4	2019	40%	6	2033	8	each		\$1,200.00	\$9,600	\$23,183	See Accessibility Chart
Play Component	Fiber Play Surface		2017	8	2025		3	3	2019	0%	0	2025	4,600	sf		\$5.00	\$23,000	\$33,560	
Play Component	Edge Restraint		2012	40	2052		4		2019	0%	0	2052	350	lf		\$38.00	\$13,300	\$106,265	Plastic Edging
PARK AMENITIES																			
Park Amenities	Pavilion		2012	25	2037		3	3	2019	0%	0	2037	280	sf		\$100.00	\$28,000	\$86,986	
Park Amenities	Benches		2012	10	2022		3	3	2019	110%	11	2033	2	each		\$1,000.00	\$2,000	\$4,830	
Park Amenities	Grill		2012	10	2022		5	3	2019	40%	4	2026	1	each		\$6,500.00	\$6,500	\$10,101	
Park Amenities	Trash/Recycling		2012	10	2022		4		2019	110%	11	2033	1	each		\$400.00	\$400	\$966	
RECREATION COMPONENTS																			
						2.00	3.27	3.38									\$216,340	\$1,016,349	

NOTES

Evaluation of building conditions focused on the elements likely to be included in the budget for items expected to require replacement or renovation within the next 10 to 15 years. Equipment, materials, or assemblies that are nominal in cost are not included. This is therefore not a comprehensive list but does identify major expenses that are likely to be incurred in the foreseeable future.

Conditions change with time, and this evaluation, along with the funds allocated to cover the associated expenses should be reviewed and revised periodically as the department's needs evolve. Unanticipated expenses can develop for a number of reasons including accelerated use or changes in use patterns, accident, or deferred general maintenance. Such reviews should include updating baseline costs and dates for the components or assemblies identified in this study.

Costs are calculated at 2019 levels and escalated at the following presumed annual rate of inflation:

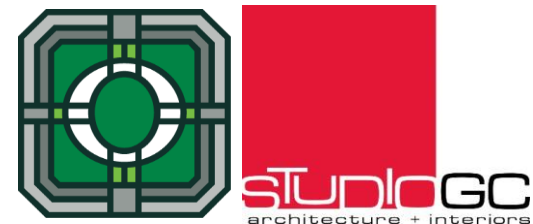
6.50% per annum

This report is broken up into different categories. The first three are organized by category with like expenses grouped together. The worksheets also covers Mechanical expenses, Electrical expenses, and Plumbing expenses. The last worksheet is organized by the computed year of expense (Budget Year).

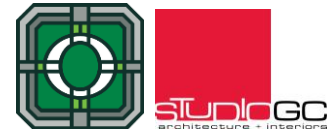
Repair/replacement work items do not include A/E Design Fees in the cost.

Total Combined Facilities

2025	\$33,560
2033	\$225,791
2037	\$86,986
2052	\$458,136
2062	\$217,471
Total:	\$1,021,945



NAME: BRENTWOOD PARK
ADDRESS: 8901 Pine St, Orland Park, IL 60462
PARK TYPE: Community
EVALUATION YEAR: 2019



PARK MAP:



PARK DATA:

Year Established:	2018
Park Age	1
Total Acreage:	5.2
Total Parking Spaces:	11

Amenities:

Playground Equipment	Little Tykes
Baseball	1 field
Soccer	1 field
Basketball	2 courts
Tennis	1 court
Water Mister	2 misters
Gaga Ball Pit	
Handicap Swing	
Pavilion	2

SECURITY COMMENTS:

Park security is as to be expected for this size facility. See a few specific areas of note and one concern:

- Great visibility from public ways
- No security level of lighting is present
- Fence should be added along all roadways adjacent to the park where the play areas are within 100 feet of the road.

Score **5.00**

ACCESSIBILITY COMMENTS

Park meets or exceeds current accessibility requirements

Score **3.50**

GENERAL CONDITION COMMENTS

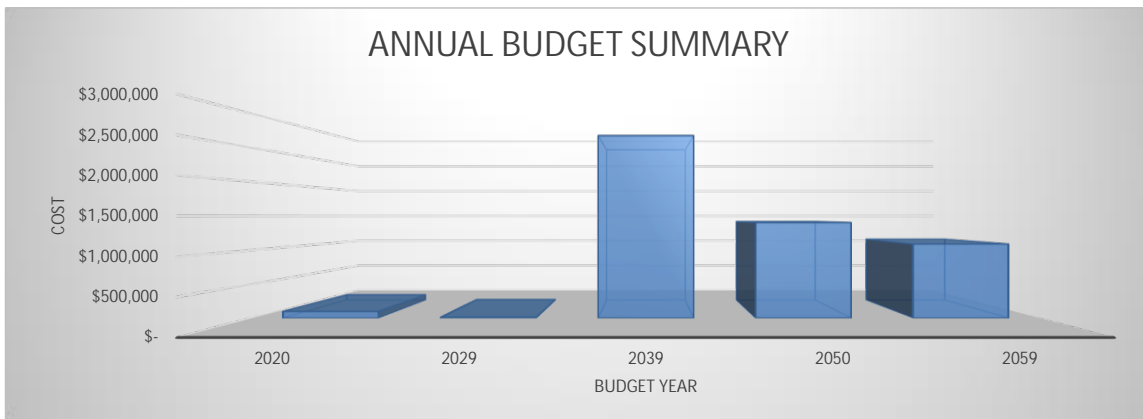
Park is essentially brand new. Very nice update.

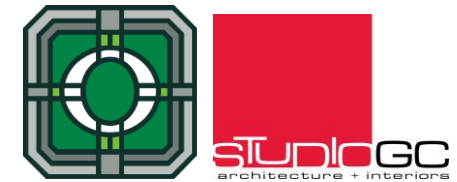
- Soccer goals are in need of a new coat of paint and re-evaluation for deterioration.
- Tennis courts are in need of resurfacing, surface cracks are evident and likely to heave over time creating tripping hazards

Score **3.81**

Score Average **4.10**

ANNUAL COST GRAPH:





COST BY BUDGET YEAR:

BRENTWOOD PARK

Budget Year	Component	Detail	Values	
			Sum of 2019 Replacement Cost	Sum of Escalated Budget
2020	SITE COMPONENTS	Asphalt - Sealcoat	\$2,872.00	\$3,058.68
		Parking Spaces/Lot (10+1HC)	\$1,200.00	\$1,278.00
	Play Component	Mulch	\$34,002.62	\$36,212.79
		Poured in Place	\$48,000.00	\$51,120.00
	RECREATION COMPONENTS	Soccer Goals	\$5,000.00	\$5,325.00
2020 Total			\$91,074.62	\$96,994.47
2029	PARK AMENITIES	Benches	\$4,000.00	\$7,508.55
		Trash/Recycling	\$1,200.00	\$2,252.56
		Bike Racks/Systems	\$1,200.00	\$2,252.56
2029 Total			\$6,400.00	\$12,013.68
2039	SITE COMPONENTS	Asphalt Replacement	\$20,104.00	\$70,839.36
		Play Component	Elevated Structures (2)	\$125,000.00
	Ground Equipment		\$10,000.00	\$35,236.45
	RECREATION COMPONENTS	Basketball Courts	\$230,000.00	\$810,438.36
		Tennis Court	\$135,000.00	\$475,692.08
		Water Mister	\$240,000.00	\$845,674.82
2039 Total			\$760,104.00	\$2,678,336.71
2050	PARK AMENITIES	Pavilion	\$164,023.80	\$1,155,432.85

Description/Life Expectancy						General Conditions			Evaluated Condition			Estimated Cost Data - 2019							
Component	Detail	Task	Installed Date	Service Life	Anticipated Replacement Date	Security (1-5)	General (1-5)	Accessibility (1-5)	Evaluation Date	Life Expectancy Modifier	Life Expectancy Beyond Evaluation (years remaining)	Budget Year	Qty	Units	Prorate	Unit Cost	2019 Replacement Cost	Escalated Budget	Comments
			(year)	(years)	(year)	(0 is lowest)	(0 is lowest)	(0 is lowest)	(year)	%	(0 is lowest)						(As of Evaluation date)		
SITE COMPONENTS																			
Site Components	Asphalt - Sealcoat		2018	2	2020				2019	0%	0	2020	2,872	sf		\$1.00	\$2,872	\$3,059	
Site Components	Asphalt Replacement		2019	15	2034		2		2019	30%	5	2039	2,872	sf		\$7.00	\$20,104	\$70,839	
Site Components	Concrete Walks		2019	40	2059		3	3	2019	0%	0	2059	11,895	sf		\$5.00	\$59,475	\$738,451	
Site Components	Landscaping		2019	50	2069		3		2019	-20%	-10	2059	195,128	sf		\$0.08	\$15,610	\$193,818	
Site Components	Parking Spaces/Lot (10+1HC)		2018	2	2020			3	2019	0%	0	2020	12	each		\$100.00	\$1,200	\$1,278	
PLAY COMPONENTS																			
						5													
Play Component	Elevated Structures (2)		2019	15	2034		5	5	2019	30%	5	2039	5	each		\$25,000.00	\$125,000	\$440,456	
Play Component	Ground Equipment		2019	15	2034		5	5	2019	30%	5	2039	4	each		\$2,500.00	\$10,000	\$35,236	
Play Component	Mulch		2010	10	2020		5	5	2019	0%	0	2020	6,801	sf		\$5.00	\$34,003	\$36,213	
Play Component	Poured in Place		2010	10	2020			5	2019	0%	0	2020	1,500	sf		\$32.00	\$48,000	\$51,120	
Play Component	Edge Restraint		2019	40	2059		4		2019	0%	0	2059	327	lf		\$38.00	\$12,426	\$154,282	
PARK AMENITIES																			
Park Amenities	Benches		2019	10	2029		4		2019	0%	0	2029	4	each		\$1,000.00	\$4,000	\$7,509	
Park Amenities	Trash/Recycling		2019	10	2029		4		2019	0%	0	2029	3	each		\$400.00	\$1,200	\$2,253	
Park Amenities	Bike Racks/Systems		2019	10	2029		4		2019	0%	0	2029	3	each		\$400.00	\$1,200	\$2,253	
Park Amenities	Pavilion		2019	25	2044		4	4	2019	25%	6	2050	1,640	sf		\$100.00	\$164,024	\$1,155,433	
RECREATION COMPONENTS																			
Recreation Components	Basketball Courts		2019	20	2039		4	3	2019	0%	0	2039	2.0	each		\$115,000.00	\$230,000	\$810,438	
Recreation Components	Baseball Field		2000	50	2050		2	1	2019	0%	0	2050	1	each		\$35,000.00	\$35,000	\$246,550	
Recreation Components	Soccer Goals		2000	20	2020		2	1	2019	0%	0	2020	1	each		\$5,000.00	\$5,000	\$5,325	
Recreation Components	Tennis Court		2019	20	2039		5	3	2019	0%	0	2039	1	each		\$135,000.00	\$135,000	\$475,692	
Recreation Components	Water Mister		2019	20	2039		5	4	2019	0%	0	2,039	2	each		\$60,000.00	\$240,000.00	\$845,675	
																	\$904,114	\$4,430,205	

NOTES

Evaluation of building conditions focused on the elements likely to be included in the budget for items expected to require replacement or renovation within the next 10 to 15 years. Equipment, materials, or assemblies that are nominal in cost are not included. This is therefore not a comprehensive list but does identify major expenses that are likely to be incurred in the foreseeable future.

Conditions change with time, and this evaluation, along with the funds allocated to cover the associated expenses should be reviewed and revised periodically as the Department's needs evolve. Unanticipated expenses can develop for a number of reasons including accelerated use or changes in use patterns, accident, or deferred general maintenance. Such reviews should include updating baseline costs and dates for the components or assemblies identified in this study.

Costs are calculated at 2019 levels and escalated at the following presumed annual rate of inflation:

6.50% per annum

This report is broken up into different categories. The first three are organized by category with like expenses grouped together. The worksheets also covers Mechanical expenses, Electrical expenses, and Plumbing expenses. The last worksheet is organized by the computed year of expense (Budget Year).

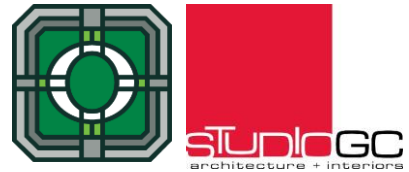
Repair/replacement work items do not include A/E Design Fees in the cost.

Total Combined Facilities

2020	\$96,994
2029	\$12,014
2039	\$2,678,337
2050	\$1,401,983
2059	\$1,086,551
Total:	\$5,275,880



NAME: BROWN PARK
ADDRESS: 14701 Westwood Dr, Orland Park, IL 60462
PARK TYPE: Mini
EVALUATION YEAR: 2019



PARK MAP:



PARK DATA:

Year Established:	1995
Park Age	24
Total Acreage:	3.4
Total Parking Spaces:	0

Amenities:

Playground Equip: Landscape Struct.
 Bike/ Walking Path
 Handicap Swing

SECURITY COMMENTS:

- Park security is moderately compromised. See a few specific areas of note:
- Park visibility is limited from public way.
 - Trimming the landscape and shrubs would help immensely.
 - No security level of lighting is present

Score **2.00**

ACCESSIBILITY COMMENTS

- This park is better accessible than would be expected for it's age.
- Given the age a full accessibility study should be completed.
 - The entries into the mulch area are not in compliance.

Score **2.67**

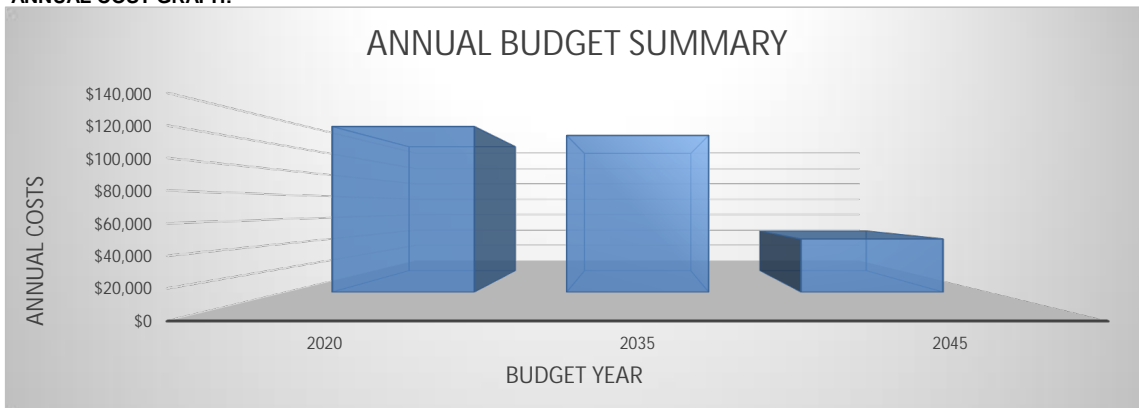
GENERAL CONDITION COMMENTS

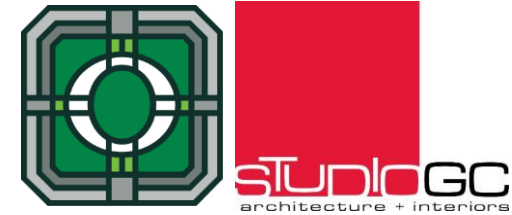
- The park is in generally good shape.
- Sidewalk repairs are necessary
 - Mildew and finish deterioration is present on the equipment.
 - Mulch appears to be overlay compacted, should be reviewed for refresh.
 - Grading issues and standing water

Score **2.38**

Score Average **2.35**

ANNUAL COST GRAPH:





COST BY BUDGET YEAR:

BROWN PARK

Budget Year	Component	Detail	Values	
			Sum of 2019 Replacement Cost	Sum of Escalated Budget
2020	PARK AMENITIES	Benches	\$6,000.00	\$6,390.00
		Trash/Recycling	\$1,500.00	\$1,597.50
	Play Component	Elevated Structures (2)	\$50,000.00	\$53,250.00
		Ground Equipment	\$2,500.00	\$2,662.50
		Mulch	\$67,720.00	\$72,121.80
2020 Total			\$127,720.00	\$136,021.80
2035	SITE COMPONENTS	Concrete Walks	\$28,710.00	\$78,637.00
	Play Component	Edge Restraint	\$18,278.00	\$50,063.64
2035 Total			\$46,988.00	\$128,700.63
2045	SITE COMPONENTS	Landscaping	\$8,494.20	\$43,672.93
2045 Total			\$8,494.20	\$43,672.93
Grand Total			\$183,202.20	\$308,395.36

Description/Life Expectancy						Assessments			Evaluated Condition			Estimated Cost Data - 2019						Comments	
Component	Detail	Task	Installed Date	Service Life	Anticipated Replacement Date	Security (1-5)	General (1-5)	Accessibility (1-5)	Evaluation Date	Life Expectancy Modifier	Life Expectancy Beyond Evaluation (years remaining)	Budget Year	Qty	Units	Prorate	Unit Cost	2019 Replacement Cost		Escalated Budget
			(year)	(years)	(year)	(0 is lowest)	(0 is lowest)	(0 is lowest)	(year)	%	(0 is lowest)						(As of Evaluation date)		
SITE COMPONENTS						2													
Site Components	Concrete Walks		1995	40	2035		2	3	2019	0%	0	2035	5,742	sf		\$5.00	\$28,710	\$78,637	
Site Components	Landscaping		1995	50	2045		1		2019	0%	0	2045	56,628	sf		\$0.15	\$8,494	\$43,673	
PLAY COMPONENTS																			
Play Component	Elevated Structures (2)		1995	15	2010		2	2	2019	65%	10	2020	2	each		\$25,000.00	\$50,000	\$53,250	
Play Component	Ground Equipment		1995	15	2010		2	2	2019	65%	10	2020	1	each		\$2,500.00	\$2,500	\$2,663	
Play Component	Mulch		2010	10	2020		2	3	2019	0%	0	2020	13,544	sf		\$5.00	\$67,720	\$72,122	
Play Component	Edge Restraint		1995	40	2035		4		2019	0%	0	2035	481	lf		\$38.00	\$18,278	\$50,064	
PARK AMENITIES																			
Park Amenities	Benches		1995	10	2005		3	3	2019	150%	15	2020	6	each		\$1,000.00	\$6,000	\$6,390	
Park Amenities	Trash/Recycling		1995	10	2005		3	3	2019	150%	15	2020	1	each		\$1,500.00	\$1,500	\$1,598	
RECREATION COMPONENTS																			
						2.0	2.4	2.7											
																	\$183,202	\$308,395	

NOTES

Evaluation of building conditions focused on the elements likely to be included in the budget for items expected to require replacement or renovation within the next 10 to 15 years. Equipment, materials, or assemblies that are nominal in cost are not included. This is therefore not a comprehensive list but does identify major expenses that are likely to be incurred in the foreseeable future.

Conditions change with time, and this evaluation, along with the funds allocated to cover the associated expenses should be reviewed and revised periodically as the Department's needs evolve. Unanticipated expenses can develop for a number of reasons including accelerated use or changes in use patterns, accident, or deferred general maintenance. Such reviews should include updating baseline costs and dates for the components or assemblies identified in this study.

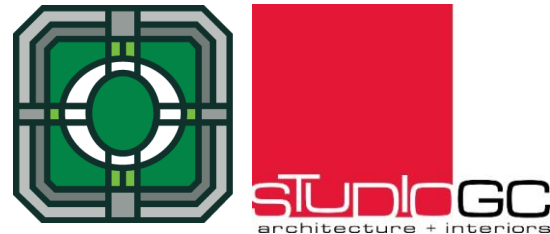
Costs are calculated at 2019 levels and escalated at the following presumed annual rate of inflation:

6.50% per annum

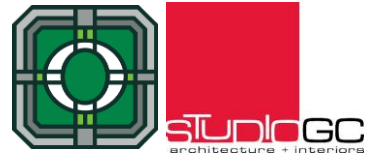
This report is broken up into different categories. The first three are organized by category with like expenses grouped together. The worksheets also covers Mechanical expenses, Electrical expenses, and Plumbing expenses. The last worksheet is organized by the computed year of expense (Budget Year).

Repair/replacement work items do not include A/E Design Fees in the cost.

Total Combined Facilities	
2020	\$136,022
2035	\$128,701
2045	\$43,673
Total:	\$308,395



NAME: BUNRATTY PARK
ADDRESS: 14045 Fermoy Ave, Orland Park, IL 60462
PARK TYPE: Neighborhood
EVALUATION YEAR: 2019



PARK MAP:



PARK DATA:

Year Established:	2008
Total Acreage:	11
Total Acreage:	4.2
Total Parking Spaces:	0

Amenities:

Playground Equipment: Landscape Structures
 Handicap Swing
 Pavilion
 Bean Bag Boards

SECURITY COMMENTS:

Park security is as to be expected for this size facility. See a few specific areas of note and one concern:
 - Great visibility from public ways
 - Security lighting should be considered if law enforcement has concerns.

Score 4.00

ACCESSIBILITY COMMENTS

Park is highly accessible. It appears to exceed the minimum requirements.

Score 3.44

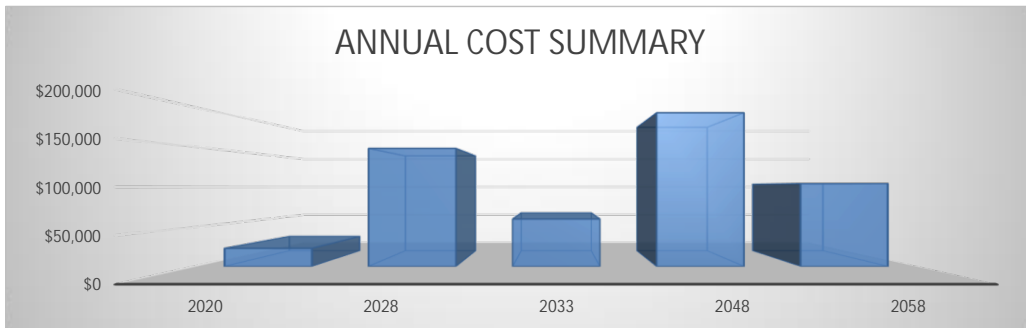
GENERAL CONDITION COMMENTS

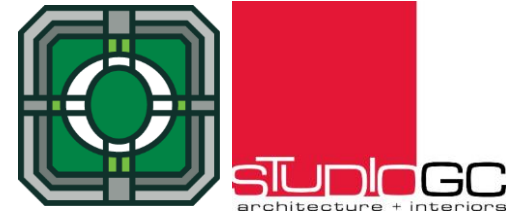
Park is in good condition and seems to be aging well. There are a few items of note:
 - There is some finish deterioration
 - There are some areas of concrete cracking. (e.g bean bag boxes)
 - Needs a drinking fountain

Score 3.82

Score Average 3.75

ANNUAL COST GRAPH:





COST BY BUDGET YEAR:

BUNRATTY PARK

Budget Year	Component	Detail	Values	
			Sum of 2019 Replacement Cost	Sum of Escalated Budget
2020	Play Component	Mulch	\$21,425.00	\$22,817.63
2020 Total			\$21,425.00	\$22,817.63
2028	SITE COMPONENTS	Concrete Patios	\$19,836.00	\$34,962.35
	PARK AMENITIES	Benches	\$5,000.00	\$8,812.85
		Trash/Recycling	\$400.00	\$705.03
		Drinking Fountain	\$6,500.00	\$11,456.71
	Play Component	Elevated Structures (2)	\$50,000.00	\$88,128.52
		Ground Equipment	\$2,500.00	\$4,406.43
2028 Total			\$84,236.00	\$148,471.88
2033	PARK AMENITIES	Pavilion	\$24,700.00	\$59,647.39
2033 Total			\$24,700.00	\$59,647.39
2048	SITE COMPONENTS	Concrete Walks	\$19,600.00	\$121,729.18
	Play Component	Edge Restraint	\$11,514.00	\$71,509.68
2048 Total			\$31,114.00	\$193,238.86
2058	SITE COMPONENTS	Landscaping	\$8,951.55	\$104,359.73
2058 Total			\$8,951.55	\$104,359.73
Grand Total			\$170,426.55	\$528,535.49

Description/Life Expectancy		Assessments				Evaluated Condition			Estimated Cost Data - 2019						Comments				
Component	Detail	Task	Installed Date	Service Life	Anticipated Replacement Date	Security (1-5)	General (1-5)	Accessibility (1-5)	Evaluation Date	Life Expectancy Modifier	Life Expectancy Beyond Evaluation (years remaining)	Budget Year	Qty	Units		Prorate	Unit Cost	2019 Replacement Cost	Escalated Budget
			(year)	(years)	(year)	(0 is lowest)	(0 is lowest)	(0 is lowest)	(year)	%	(0 is lowest)							(As of Evaluation date)	
Park Security						4													
SITE COMPONENTS																			
Site Components	Concrete Walks		2008	40	2048		4	4	2019	0%	0	2048	3,920	sf		\$5.00	\$19,600	\$121,729	
Site Components	Concrete Patios		2008	20	2028		4	4	2019	0%	0	2028	1,102	sf		\$18.00	\$19,836	\$34,962	
Site Components	Landscaping		2008	50	2058		2		2019	0%	0	2058	59,677	sf		\$0.15	\$8,952	\$104,360	
PLAY COMPONENTS																			
Play Component	Elevated Structures (2)		2008	15	2023		4	4	2019	30%	5	2028	2	each		\$25,000.00	\$50,000	\$88,129	
Play Component	Ground Equipment		2008	15	2023		4	4	2019	30%	5	2028	1	each		\$2,500.00	\$2,500	\$4,406	
Play Component	Mulch		2010	10	2020		3	3	2019	0%	0	2020	4,285	sf		\$5.00	\$21,425	\$22,818	
Play Component	Edge Restraint		2008	40	2048		5		2019	0%	0	2048	303	lf		\$38.00	\$11,514	\$71,510	
PARK AMENITIES																			
Park Amenities	Benches		2008	10	2018		4	3	2019	100%	10	2028	5	each		\$1,000.00	\$5,000	\$8,813	
Park Amenities	Drinking Fountain		2008	10	2018		4	3	2019	100%	10	2028	1	each		\$6,500.00	\$6,500	\$11,457	
Park Amenities	Trash/Recycling		2008	10	2018		4	3	2019	100%	10	2028	1	each		\$400.00	\$400	\$705	
Park Amenities	Pavilion		2008	25	2033		4	3	2019	0%	0	2033	247	sf		\$100.00	\$24,700	\$59,647	
RECREATION COMPONENTS																			
						4.00	3.82	3.44							\$170,427	\$528,535			

NOTES

Evaluation of building conditions focused on the elements likely to be included in the budget for items expected to require replacement or renovation within the next 10 to 15 years. Equipment, materials, or assemblies that are nominal in cost are not included. This is therefore not a comprehensive list but does identify major expenses that are likely to be incurred in the foreseeable future.

Conditions change with time, and this evaluation, along with the funds allocated to cover the associated expenses should be reviewed and revised periodically as the Department's needs evolve. Unanticipated expenses can develop for a number of reasons including accelerated use or changes in use patterns, accident, or deferred general maintenance. Such reviews should include updating baseline costs and dates for the components or assemblies identified in this study.

Costs are calculated at 2019 levels and escalated at the following presumed annual rate of inflation:

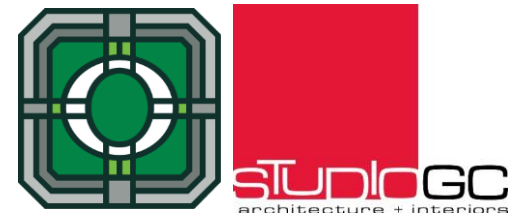
6.50% per annum

This report is broken up into different categories. The first three are organized by category with like expenses grouped together. The worksheets also covers Mechanical expenses, Electrical expenses, and Plumbing expenses. The last worksheet is organized by the computed year of expense (Budget Year).

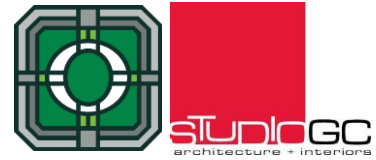
Repair/replacement work items do not include A/E Design Fees in the cost.

Total Combined Facilities

2020	\$22,818
2028	\$148,472
2033	\$59,647
2048	\$193,239
2058	\$104,360
Total:	\$528,535



NAME: CACHEY PARK
ADDRESS: 8401 Wheeler Dr, Orland Park, IL 60462
PARK TYPE: Community
EVALUATION YEAR: 2019



PARK MAP:



PARK DATA:

Year Renovated	1996
Park Age:	23
Total Acreage:	17.5
Total Parking Spaces	15

Amenities:

Playground Equip:	Burke
Baseball	2
Bocce Ball	2
Basketball	2
Drinking fountain	
LaCrosse Field	
Pavilion	
Pickleball	
Picnic Grills	
Playground	
Soccer Fields	9
Tennis Courts	3

Score **3.00**

SECURITY COMMENTS:

- The park is above average from a safety and security perspective.
- The general site lighting and good visibility from the road side provides a higher level of security.
- The location of the playground is reasonable and the trees provide good coverage from out of control vehicles
- Fence should be added along all roadways adjacent to the park where the play areas are within 100 feet of the road.

ACCESSIBILITY COMMENTS

Score **2.31**

- Though a final accessibility review should be completed the park appears to meet the 2010 Accessibility Standards.
- Other items of note:
 - The condition of the pavilion paving limits accessibility.
 - There are no ramps into the mulch area.
 - The soccer and Basketball courts are not accessible
 - Sand pit is not accessible for use

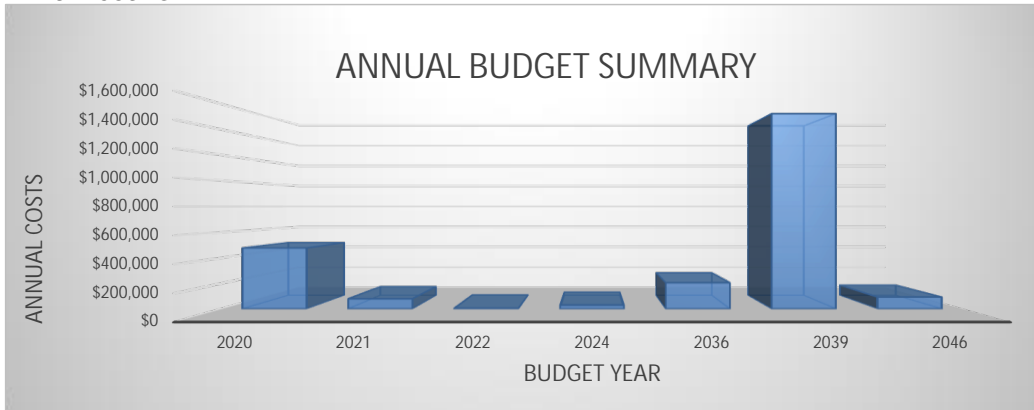
GENERAL CONDITION COMMENTS

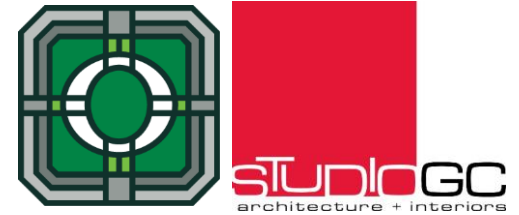
Score **2.72**

- Park is in generally good condition given it's age.
- Finish deterioration on the amenities.
- Basketball lighting is deteriorated and needs replacement
- Staff has consistent maintenance issues with play equipment.

Score Average **2.68**

ANNUAL COST GRAPH:





COST BY BUDGET YEAR:

CACHEY PARK

Budget Year	Component	Detail	Values	
			Sum of 2019 Replacement Cost	Sum of Escalated Budget
2020	PARK AMENITIES	Benches	\$8,000.00	\$8,520.00
		Trash/Recycling	\$2,400.00	\$2,556.00
		Drinking Fountains	\$3,000.00	\$3,195.00
	Play Component	Elevated Structures (2)	\$125,000.00	\$133,125.00
		Ground Equipment	\$2,400.00	\$2,556.00
		Mulch	\$38,780.00	\$41,300.70
	RECREATION COMPONENTS	Basketball Courts	\$230,000.00	\$244,950.00
		Fencing	\$37,100.00	\$39,511.50
2020 Total			\$446,680.00	\$475,714.20
2021	SITE COMPONENTS	Concrete Patios	\$9,990.00	\$11,330.91
		Pavilion	\$50,000.00	\$56,711.25
	PARK AMENITIES	Park Lighting	\$10,000.00	\$11,342.25
2021 Total			\$69,990.00	\$79,384.41
2022	SITE COMPONENTS	Asphalt - Sealcoat	\$3,927.00	\$4,743.62
2022 Total			\$3,927.00	\$4,743.62
2024	SITE COMPONENTS	Parking Spaces/Lot (10+1HC)	\$1,500.00	\$2,055.13
	RECREATION COMPONENTS	Soccer Goals (practice)	\$20,000.00	\$27,401.73
2024 Total			\$21,500.00	\$29,456.86
2036	SITE COMPONENTS	Concrete Walks	\$45,050.00	\$131,412.94
	Play Component	Edge Restraint	\$24,966.00	\$72,826.98
2036 Total			\$70,016.00	\$204,239.92
2039	SITE COMPONENTS	Asphalt Replacement	\$27,489.00	\$96,861.48
	RECREATION COMPONENTS	Tennis Court	\$405,000.00	\$1,427,076.25
2039 Total			\$432,489.00	\$1,523,937.73
2046	SITE COMPONENTS	Landscaping	\$16,896.90	\$92,522.30
2046 Total			\$16,896.90	\$92,522.30
Grand Total			\$1,061,498.90	\$2,409,999.04

CACHEY PARK 8401 Wheeler Dr, Orland Park, IL 60462																			
Description/Life Expectancy						Assessments			Evaluated Condition			Estimated Cost Data - 2019						Comments	
Component	Detail	Task	Installed Date	Service Life	Anticipated Replacement Date	Security (1-5)	General (1-5)	Accessibility (1-5)	Evaluation Date	Life Expectancy Modifier	Life Expectancy Beyond Evaluation (years remaining)	Budget Year	Qty	Units	Prorate	Unit Cost	2019 Replacement Cost		Escalated Budget
			(year)	(years)	(year)	(0 is lowest)	(0 is lowest)	(0 is lowest)	(year)	%	(0 is lowest)						(As of Evaluation date)		
Park Security																			
SITE COMPONENTS						3													
Site Components	Asphalt - Sealcoat		2019	2	2021		5		2019	25%	1	2022	3,927	sf		\$1.00	\$3,927	\$4,744	
Site Components	Asphalt Replacement		2019	15	2034		5	3	2019	30%	5	2039	3,927	sf		\$7.00	\$27,489	\$96,861	
Site Components	Concrete Walks		1996	40	2036		2	2	2019	0%	0	2036	9,010	sf		\$5.00	\$45,050	\$131,413	
Site Components	Concrete Patios		1996	20	2016		1	2	2019	22%	4	2021	555	sf		\$18.00	\$9,990	\$11,331	
Site Components	Landscaping		1996	50	2046				2019	0%	0	2046	563,230	sf		\$0.03	\$16,897	\$92,522	
Site Components	Parking Spaces/Lot (10+1HC)		2019	5	2024		5		2019	0%	0	2024	15	each		\$100.00	\$1,500	\$2,055	
PLAY COMPONENTS						3													
Play Component	Elevated Structures (2)		1996	15	2011		2	3	2019	60%	9	2020	5	each		\$25,000.00	\$125,000	\$133,125	
Play Component	Ground Equipment		1996	15	2011		2	3	2019	60%	9	2020	2	each		\$1,200.00	\$2,400	\$2,556	
Play Component	Mulch		2010	10	2020		1	1	2019	0%	0	2020	7,756	sf		\$5.00	\$38,780	\$41,301	
Play Component	Sand Pit Area		1996	10	2006		1	1	2019	0%	0	2006	7,756	sf		\$5.00	\$38,780	\$17,103	
Play Component	Edge Restraint		1996	40	2036		4		2019	0%	0	2036	657	lf		\$38.00	\$24,966	\$72,827	
PARK AMENITIES																			
Park Amenities	Park Lighting		1996	20	2016				2019	22%	4	2021	4	each		\$2,500.00	\$10,000	\$11,342	
Park Amenities	Benches		1996	10	2006		2		2019	140%	14	2020	8	each		\$1,000.00	\$8,000	\$8,520	
Park Amenities	Trash/Recycling		1996	10	2006		2		2019	140%	14	2020	6	each		\$400.00	\$2,400	\$2,556	
Park Amenities	Drinking Fountains		1996	15	2011				2019	60%	9	2020	1	each		\$3,000.00	\$3,000	\$3,195	
Park Amenities	Pavilion		1996	25	2021		2	3	2019	0%	0	2021	500	sf		\$100.00	\$50,000	\$56,711	
RECREATION COMPONENTS																			
Recreation Components	Basketball Courts		1996	20	2016		2	1	2019	20%	4	2020	2.0	each		\$115,000.00	\$230,000	\$244,950	
Recreation Components	Tennis Court		2019	20	2039		5	3	2019	0%	0	2039	3	each		\$135,000.00	\$405,000	\$1,427,076	
Recreation Components	Soccer Goals (practice)		2018	6	2024		3	3	2019	0%	0	2024	4	each		\$5,000.00	\$20,000	\$27,402	
Recreation Components	Fencing		1996	10	2006		3	3	2019	140%	14	2020	371	lf		\$100.00	\$37,100	\$39,512	
Recreation Components	Bocce Ball		1996				2	2					1	each					
						3.00	2.72	2.31							\$1,043,179	\$2,360,188			

NOTES

Evaluation of building conditions focused on the elements likely to be included in the budget for items expected to require replacement or renovation within the next 10 to 15 years. Equipment, materials, or assemblies that are nominal in cost are not included. This is therefore not a comprehensive list but does identify major expenses that are likely to be incurred in the foreseeable future.

Conditions change with time, and this evaluation, along with the funds allocated to cover the associated expenses should be reviewed and revised periodically as the Department's needs evolve. Unanticipated expenses can develop for a number of reasons including accelerated use or changes in use patterns, accident, or deferred general maintenance. Such reviews should include updating baseline costs and dates for the components or assemblies identified in this study.

Costs are calculated at 2019 levels and escalated at the following presumed annual rate of inflation:

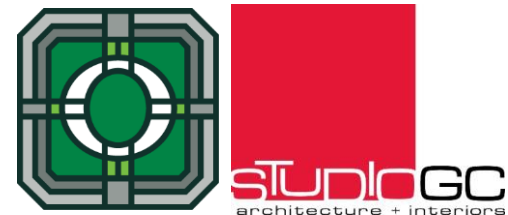
6.50% per annum

This report is broken up into different categories. The first three are organized by category with like expenses grouped together. The worksheets also covers Mechanical expenses, Electrical expenses, and Plumbing expenses. The last worksheet is organized by the computed year of expense (Budget Year).

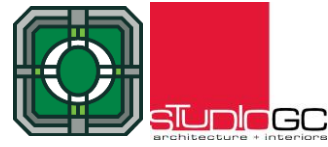
Repair/replacement work items do not include A/E Design Fees in the cost.

Total Combined Facilities

2020	\$475,714
2021	\$79,384
2022	\$4,744
2024	\$29,457
2036	\$204,240
2039	\$1,523,938
2046	\$92,522
Total:	\$2,409,999



NAME: CAMENO REAL PARK
ADDRESS: 15232 El Cameno Terrace, Orland Park, IL 60462
PARK TYPE: Neighborhood
EVALUATION YEAR: 2019



PARK MAP:



PARK DATA:

Year Renovated:	1997
Park Age	22
Total Acreage:	0.5
Total Parking Spaces:	13

Amenities:

Playground Equip: Landscape Structures
 Bike/ Walking Path
 Pergola

SECURITY COMMENTS:

- The park has some security concerns that should be reviewed and implemented:
- No security level lighting
 - Poor visibility to the playground due to distance and landscaping
 - Fence should be added along all roadways adjacent to the park where the play areas are within 100 feet of the road.

Score **2.00**

L

ACCESSIBILITY COMMENTS

- Park was constructed prior to the 2010 ADA requirements. Playground equipment though appears to meet the standards of accessibility. A few items of note:
- PIP tiles do not meet the accessibility requirements for access to the mulch.
 - Sand area for the ground equipment is not accessible

Score **2.50**

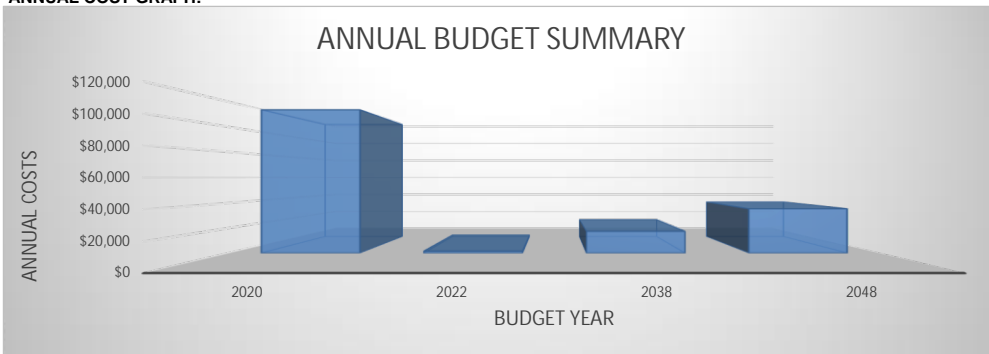
GENERAL CONDITION COMMENTS

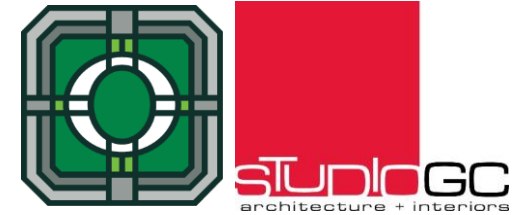
- The park is in reasonable condition given it's age. A few items of note:
- Edge restraints are either missing or overgrown in areas
 - Edge restraint in one area is concrete retaining blocks that are deteriorating or shifted.
 - Equipment has cosmetic issues that could be addressed.

Score **2.73**

Score Average **2.41**

ANNUAL COST GRAPH:





COST BY BUDGET YEAR:

CAMENO REAL PARK

Budget Year	Component	Detail	Values	
			Sum of 2019 Replacement Cost	Sum of Escalated Budget
2020	SITE COMPONENTS	Asphalt - Sealcoat	\$2,249.00	\$2,395.19
		Asphalt Replacement	\$15,743.00	\$16,766.30
	PARK AMENITIES	Benches	\$3,000.00	\$3,195.00
		Trash/Recycling	\$1,500.00	\$1,597.50
	Play Component	Elevated Structures (2)	\$50,000.00	\$53,250.00
		Ground Equipment	\$10,000.00	\$10,650.00
		Mulch	\$13,325.00	\$14,191.13
		Edge Restraint	\$10,868.00	\$11,574.42
2020 Total			\$106,685.00	\$113,619.53
2022	SITE COMPONENTS	Parking Spaces/Lot (10+1HC)	\$1,300.00	\$1,570.33
2022 Total			\$1,300.00	\$1,570.33
2038	SITE COMPONENTS	Concrete Walks	\$5,225.00	\$17,287.37
2038 Total			\$5,225.00	\$17,287.37
2048	SITE COMPONENTS	Landscaping	\$5,662.80	\$35,169.80
2048 Total			\$5,662.80	\$35,169.80
Grand Total			\$118,872.80	\$167,647.02

Description/Life Expectancy						Assessments			Evaluated Condition			Estimated Cost Data - 2019						Comments	
Component	Detail	Task	Installed Date	Service Life	Anticipated Replacement Date	Security (1-5)	General (1-5)	Accessibility (1-5)	Evaluation Date	Life Expectancy Modifier	Life Expectancy Beyond Evaluation (years remaining)	Budget Year	Qty	Units	Prorate	Unit Cost	2019 Replacement Cost		Escalated Budget
			(year)	(years)	(year)	(0 is lowest)	(0 is lowest)	(0 is lowest)	(year)	%	(0 is lowest)						(As of Evaluation date)		
SITE COMPONENTS						2													
Site Components	Asphalt - Sealcoat		2017	2	2019		3		2019	25%	1	2020	2,249	sf		\$1.00	\$2,249	\$2,395	2 Handicapped
Site Components	Asphalt Replacement		1998	15	2013		3		2019	45%	7	2020	2,249	sf		\$7.00	\$15,743	\$16,766	
Site Components	Concrete Walks		1998	40	2038		2	3	2019	0%	0	2038	1,045	sf		\$5.00	\$5,225	\$17,287	
Site Components	Landscaping		1998	50	2048		2		2019	0%	0	2048	21,780	sf		\$0.26	\$5,663	\$35,170	
Site Components	Parking Spaces/Lot (10+1HC)		2017	5	2022		3		2019	0%	0	2022	13	each		\$100.00	\$1,300	\$1,570	
PLAY COMPONENTS						2													
Play Component	Elevated Structures (2)		1998	15	2013		3	4	2019	45%	7	2020	2	each		\$25,000.00	\$50,000	\$53,250	See Accessibility Chart
Play Component	Ground Equipment		1998	15	2013		3	1	2019	45%	7	2020	4	each		\$2,500.00	\$10,000	\$10,650	See Accessibility Chart
Play Component	Mulch		2010	10	2020		3	2	2019	0%	0	2020	2,665	sf		\$5.00	\$13,325	\$14,191	
Play Component	Edge Restraint		1998	40	2038		2		2019	-45%	-18	2020	286	lf		\$38.00	\$10,868	\$11,574	Plastic Edging
PARK AMENITIES						2													
Park Amenities	Benches		1998	10	2008		3		2019	120%	12	2020	2	each		\$1,500.00	\$3,000	\$3,195	
Park Amenities	Trash/Recycling		1998	10	2008		3		2019	120%	12	2020	1	each		\$1,500.00	\$1,500	\$1,598	
RECREATION COMPONENTS																			
						2.00	2.73	2.50											
																	\$49,813	\$64,438	

NOTES

Evaluation of building conditions focused on the elements likely to be included in the budget for items expected to require replacement or renovation within the next 10 to 15 years. Equipment, materials, or assemblies that are nominal in cost are not included. This is therefore not a comprehensive list but does identify major expenses that are likely to be incurred in the foreseeable future.

Conditions change with time, and this evaluation, along with the funds allocated to cover the associated expenses should be reviewed and revised periodically as the Department's needs evolve. Unanticipated expenses can develop for a number of reasons including accelerated use or changes in use patterns, accident, or deferred general maintenance. Such reviews should include updating baseline costs and dates for the components or assemblies identified in this study.

Costs are calculated at 2019 levels and escalated at the following presumed annual rate of inflation:

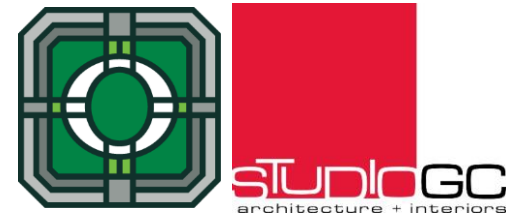
6.50% per annum

This report is broken up into different categories. The first three are organized by category with like expenses grouped together. The worksheets also covers Mechanical expenses, Electrical expenses, and Plumbing expenses. The last worksheet is organized by the computed year of expense (Budget Year).

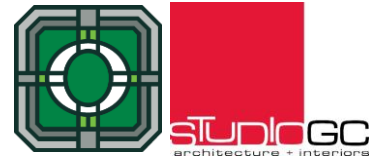
Repair/replacement work items do not include A/E Design Fees in the cost.

Total Combined Facilities

2020	\$113,620
2022	\$1,570
2038	\$17,287
2048	\$35,170
Total:	\$167,647



NAME: CENTENNIAL HERTZ PARK
ADDRESS: 15600 West Avenue Orland Park, IL 60462
PARK TYPE: Community
EVALUATION YEAR: 2019



PARK MAP:



PARK DATA:

Year Renovated:	2012
Park Age	7
Total Acreage:	192
Total Parking Spaces	562

Amenities:

Playground Equipment: Landscape Struct.
 Baseball/Softball Fields 9
 Bean Bag Boards
 Walking Paths
 Pavilions
 Skate Park
 Soccer Fields 8
 Volley Ball
 Water Park

SECURITY COMMENTS:

Park is well lit and easy access for supervision. No security concerns.

Score **4.00**

ACCESSIBILITY COMMENTS

Park is generally ADA accessible. There are a few items of note:
 - Playground is new and appears to meet accessibility regulations
 - The soccer stands are not connected to the asphalt pathways
 - The soccer stands are too wide for the asphalt platforms and not leaving any locations for handicapped spectators.
 - Slopes at the baseball fields are in excess of the accessibility code.

Score **3.40**

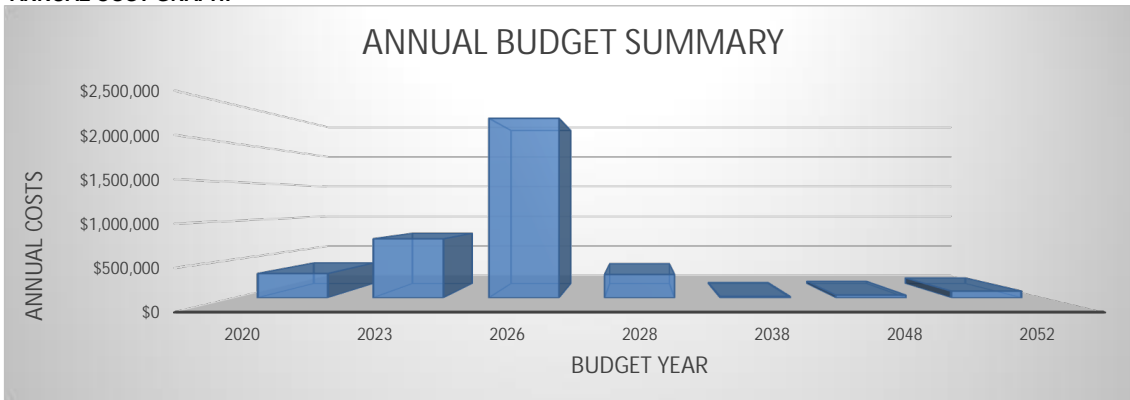
GENERAL CONDITION COMMENTS

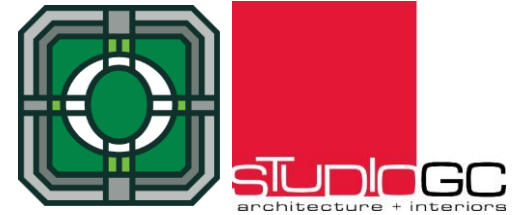
Park is generally in very good condition. A few items of note:
 - Soccer fields exhibit typical deterioration at goals and center pitch.
 - Playground is in very good condition as is the PIP.
 - Spectator and dugout areas for the baseball fields are deteriorated and the retaining walls are in need of significant repairs.
 - Baseball fencing and backstops are rusting and are in need of replacement.
 - Staff noted the play area is sinking. This should be investigated.

Score **3.62**

Score Average **3.67**

ANNUAL COST GRAPH:





COST BY BUDGET YEAR:

CENTENNIAL HERTZ PARK

Budget Year	Component	Detail	Values	
			Sum of 2019 Replacement Cost	Sum of Escalated Budget
2020	SITE COMPONENTS	Asphalt - Sealcoat	\$214,000.00	\$227,910.00
		Parking Spaces/Lot (10+1HC)	\$78,680.00	\$83,794.20
	PARK AMENITIES	Benches	\$2,000.00	\$2,130.00
		Trash/Recycling	\$1,200.00	\$1,278.00
2020 Total			\$295,880.00	\$315,112.20
2023	RECREATION COMPONENTS	Soccer Fields	\$280,000.00	\$360,210.58
		Baseball Field	\$315,000.00	\$405,236.90
2023 Total			\$595,000.00	\$765,447.48
2026	SITE COMPONENTS	Asphalt Replacement	\$1,498,000.00	\$2,327,871.85
2026 Total			\$1,498,000.00	\$2,327,871.85
2028	Play Component	Elevated Structures (2)	\$50,000.00	\$88,128.52
		Ground Equipment	\$10,000.00	\$17,625.70
		PIP	\$111,930.00	\$197,284.50
2028 Total			\$171,930.00	\$303,038.73
2038	SITE COMPONENTS	Concrete Walks	\$5,225.00	\$17,287.37
2038 Total			\$5,225.00	\$17,287.37
2048	SITE COMPONENTS	Landscaping	\$5,662.80	\$35,169.80
2048 Total			\$5,662.80	\$35,169.80
2052	Play Component	Edge Restraint	\$10,868.00	\$86,833.38
2052 Total			\$10,868.00	\$86,833.38
Grand Total			\$2,582,565.80	\$3,850,760.79

Description/Life Expectancy						Assessments			Evaluated Condition			Estimated Cost Data - 2019								
Component	Detail	Task	Installed Date	Service Life	Anticipated Replacement Date	Security (1-5)	General (1-5)	Accessibility (1-5)	Evaluation Date	Life Expectancy Modifier	Life Expectancy Beyond Evaluation (years remaining)	Budget Year	Qty	Units	Prorate	Unit Cost	2019 Replacement Cost	Escalated Budget	Comments	
			(year)	(years)	(year)	(0 is lowest)	(0 is lowest)	(0 is lowest)	(year)	%	(0 is lowest)						(As of Evaluation date)			
SITE COMPONENTS						4														
Site Components	Asphalt - Sealcoat		2017	2	2019		3		2019	25%	1	2020	214,000	sf		\$1.00	\$214,000	\$227,910		
Site Components	Asphalt Replacement		2008	15	2023		3		2019	20%	3	2026	214,000	sf		\$7.00	\$1,498,000	\$2,327,872		
Site Components	Concrete Walks		1998	40	2038		2		2019	0%	0	2038	1,045	sf		\$5.00	\$5,225	\$17,287		
Site Components	Landscaping		1998	50	2048		2		2019	0%	0	2048	21,780	sf		\$0.26	\$5,663	\$35,170		
Site Components	Parking Spaces/Lot (10+1HC)		2017	2	2019		3		2019	25%	1	2020	562	each		\$140.00	\$78,680	\$83,794	2 Handicapped	
PLAY COMPONENTS																				
Play Component	Elevated Structures (2)		2012	15	2027		5	5	2019	5%	1	2028	2	each		\$25,000.00	\$50,000	\$88,129	See Accessibility Chart	
Play Component	Ground Equipment		2012	15	2027		5	5	2019	5%	1	2028	4	each		\$2,500.00	\$10,000	\$17,626	See Accessibility Chart	
Play Component	PIP		2012	15	2027		5	5	2019	5%	1	2028	2,665	sf		\$42.00	\$111,930	\$197,285		
Play Component	Edge Restraint		2012	40	2052		5		2019	0%	0	2052	286	lf		\$38.00	\$10,868	\$86,833	Plastic Edging	
PARK AMENITIES																				
Park Amenities	Benches		1998	10	2008		5		2019	120%	12	2020	2	each		\$1,000.00	\$2,000	\$2,130		
Park Amenities	Trash/Recycling		1998	10	2008		5		2019	120%	12	2020	1	each		\$1,200.00	\$1,200	\$1,278		
RECREATION COMPONENTS																				
Recreation Components	Soccer Fields		1998	25	2023		2	1	2019	0%	0	2023	8	each		\$35,000.00	\$280,000	\$360,211		
Recreation Components	Baseball Field		1998	25	2023		2	1	2019	0%	0	2023	9	each		\$35,000.00	\$315,000	\$405,237		
						4.00	3.62	3.40									\$2,582,566	\$3,850,761		

NOTES

Evaluation of building conditions focused on the elements likely to be included in the budget for items expected to require replacement or renovation within the next 10 to 15 years. Equipment, materials, or assemblies that are nominal in cost are not included. This is therefore not a comprehensive list but does identify major expenses that are likely to be incurred in the foreseeable future.

Conditions change with time, and this evaluation, along with the funds allocated to cover the associated expenses should be reviewed and revised periodically as the Department's needs evolve. Unanticipated expenses can develop for a number of reasons including accelerated use or changes in use patterns, accident, or deferred general maintenance. Such reviews should include updating baseline costs and dates for the components or assemblies identified in this study.

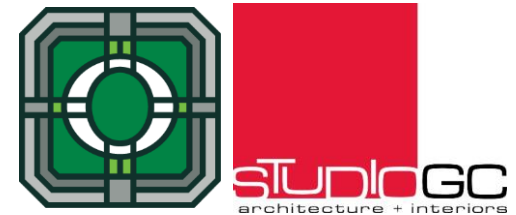
Costs are calculated at 2019 levels and escalated at the following presumed annual rate of inflation:

6.50% per annum

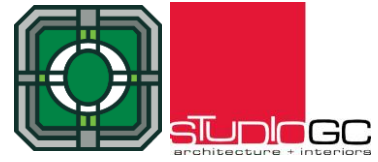
This report is broken up into different categories. The first three are organized by category with like expenses grouped together. The worksheets also covers Mechanical expenses, Electrical expenses, and Plumbing expenses. The last worksheet is organized by the computed year of expense (Budget Year).

Repair/replacement work items do not include A/E Design Fees in the cost.

Total Combined Facilities	
2020	\$315,112
2023	\$765,447
2026	\$2,327,872
2028	\$303,039
2038	\$17,287
2048	\$35,170
2052	\$86,833
Total:	\$3,763,927



NAME: COLETTE HIGHLANDS PARK
ADDRESS: 15701 Park Station Blvd, Orland Park
PARK TYPE: Neighborhood
EVALUATION YEAR: 2019



PARK MAP:



PARK DATA:

Year Renovated:	2012
Park Age:	7
Total Acreage:	2
Total Parking Spaces:	0

Amenities:

- Playground Equip:
- Drinking Fountain
- Handicap Swing
- Pavilion
- Fishing

SECURITY COMMENTS:

Score **4.00**

Park security is as to be expected for this size facility. See a few specific areas of note and one concern:

- Great visibility from public ways
- Security lighting should be considered if law enforcement has concerns.

ACCESSIBILITY COMMENTS

Score **3.38**

The park was constructed after the 2010 Accessibility Guidelines and appears to be in compliance. A few items to verify:

- Pathways are wide to accommodate all users
- There appears to be additional ground experiences beyond what is required.

GENERAL CONDITION COMMENTS

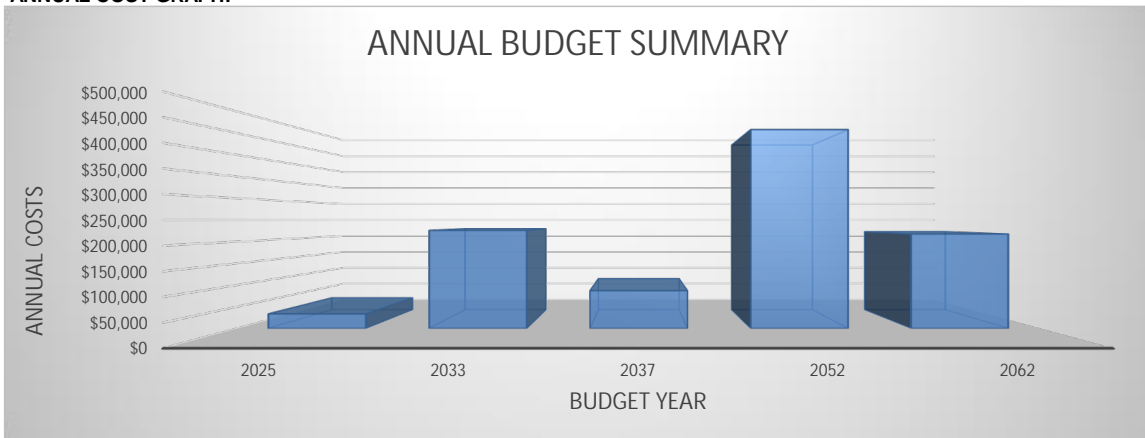
Score **4.36**

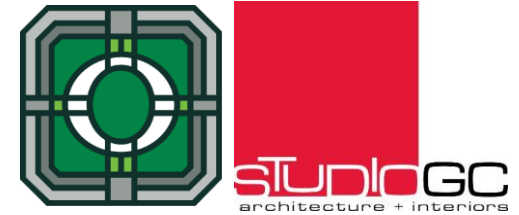
The park is in very good condition.

- No signs of finish deterioration
- Play surface is in very good condition and appears to have been recently refreshed.

Score Average **3.91**

ANNUAL COST GRAPH:





COST BY BUDGET YEAR:

COLETTE HIGHLANDS PARK

Budget Year	Component	Detail	Values	
			Sum of 2019 Replacement Cost	Sum of Escalated Budget
2025	Play Component	Fiber Play Surface	\$23,000.00	\$33,560.27
2025 Total			\$23,000.00	\$33,560.27
2033	PARK AMENITIES	Benches	\$2,000.00	\$4,829.75
		Trash/Recycling	\$400.00	\$965.95
		Drinking Fountain	\$6,500.00	\$15,696.68
	Play Component	Elevated Structures (2)	\$75,000.00	\$181,115.56
		Ground Equipment	\$9,600.00	\$23,182.79
2033 Total			\$93,500.00	\$225,790.74
2037	PARK AMENITIES	Pavilion	\$28,000.00	\$86,986.32
2037 Total			\$28,000.00	\$86,986.32
2052	SITE COMPONENTS	Concrete Walks	\$15,240.00	\$121,764.87
		Concrete Patio	\$28,800.00	\$230,106.85
	Play Component	Edge Restraint	\$13,300.00	\$106,264.62
2052 Total			\$57,340.00	\$458,136.34
2062	SITE COMPONENTS	Landscaping	\$14,500.00	\$217,470.89
2062 Total			\$14,500.00	\$217,470.89
Grand Total			\$216,340.00	\$1,021,944.57

Description/Life Expectancy		Task	Installed Date	Service Life	Anticipated Replacement Date	Assessments			Evaluated Condition			Estimated Cost Data - 2019						Comments		
Component	Detail		(year)	(years)	(year)	Security (1-5)	General (1-5)	Accessibility (1-5)	Evaluation Date	Life Expectancy Modifier	Life Expectancy Beyond Evaluation (years remaining)	Budget Year	Qty	Units	Prorate	Unit Cost	2019 Replacement Cost	Escalated Budget		
						(0 is lowest)	(0 is lowest)	(0 is lowest)	(year)	%	(0 is lowest)						(As of Evaluation date)			
SITE COMPONENTS						4														
Site Components	Concrete Walks		2012	40	2052		5	4	2019	0%	0	2052	3,048	sf		\$5.00	\$15,240	\$121,765		
Site Components	Concrete Patio		2012	40	2052		4	3	2019	0%	0	2052	1,600	sf		\$18.00	\$28,800	\$230,107		
Site Components	Landscaping		2012	50	2062		4		2019	0%	0	2062	58,000	sf		\$0.25	\$14,500	\$217,471		
PLAY COMPONENTS																				
Play Component	Elevated Structures (2)		2012	15	2027		4	4	2019	40%	6	2033	3	each		\$25,000.00	\$75,000	\$181,116	See Accessibility Chart	
Play Component	Ground Equipment		2012	15	2027		4	4	2019	40%	6	2033	8	each		\$1,200.00	\$9,600	\$23,183	See Accessibility Chart	
Play Component	Fiber Play Surface		2017	8	2025		5	3	2019	0%	0	2025	4,600	sf		\$5.00	\$23,000	\$33,560		
Play Component	Edge Restraint		2012	40	2052		5		2019	0%	0	2052	350	lf		\$38.00	\$13,300	\$106,265	Plastic Edging	
PARK AMENITIES																				
Park Amenities	Pavilion		2012	25	2037		4	3	2019	0%	0	2037	280	sf		\$100.00	\$28,000	\$86,986		
Park Amenities	Benches		2012	10	2022		4	3	2019	110%	11	2033	2	each		\$1,000.00	\$2,000	\$4,830		
Park Amenities	Drinking Fountain		2012	15	2027		5	3	2019	40%	6	2033	1	each		\$6,500.00	\$6,500	\$15,697		
Park Amenities	Trash/Recycling		2012	10	2022		4		2019	110%	11	2033	1	each		\$400.00	\$400	\$966		
RECREATION COMPONENTS																				
						4.00	4.36	3.38										\$216,340	\$1,021,945	

NOTES

Evaluation of building conditions focused on the elements likely to be included in the budget for items expected to require replacement or renovation within the next 10 to 15 years. Equipment, materials, or assemblies that are nominal in cost are not included. This is therefore not a comprehensive list but does identify major expenses that are likely to be incurred in the foreseeable future.

Conditions change with time, and this evaluation, along with the funds allocated to cover the associated expenses should be reviewed and revised periodically as the department's needs evolve. Unanticipated expenses can develop for a number of reasons including accelerated use or changes in use patterns, accident, or deferred general maintenance. Such reviews should include updating baseline costs and dates for the components or assemblies identified in this study.

Costs are calculated at 2019 levels and escalated at the following presumed annual rate of inflation:

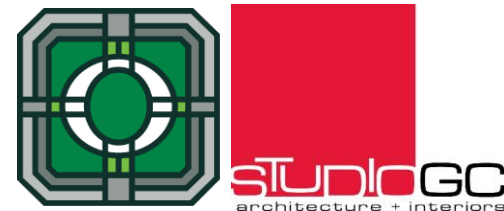
6.50% per annum

This report is broken up into different categories. The first three are organized by category with like expenses grouped together. The worksheets also covers Mechanical expenses, Electrical expenses, and Plumbing expenses. The last worksheet is organized by the computed year of expense (Budget Year).

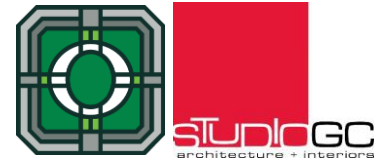
Repair/replacement work items do not include A/E Design Fees in the cost.

Total Combined Facilities

2025	\$33,560
2033	\$225,791
2037	\$86,986
2052	\$458,136
2062	\$217,471
Total:	\$1,021,945



NAME: COLONIAL PARK
ADDRESS: 9324 139 St, Orland Park, IL 60462
PARK TYPE: Neighborhood
EVALUATION YEAR: 2019



PARK MAP:



PARK DATA:

Year Renovated:	1998
Park Age	21
Total Acreage:	2.7
Total Parking Spaces:	0

Amenities:

Playground Equip: Gametime
 Bike/ Walking Path
 Pavilion
 Picnic Grills

SECURITY COMMENTS:

Score **4.00**

Park security is as to be expected for this size facility. See a few specific areas of note and one concern:

- Great visibility from public ways
- Security lighting should be considered if law enforcement has concerns.

ACCESSIBILITY COMMENTS

Score **2.57**

Park was constructed prior to the 2010 Accessibility Law.

- The fiber surfacing appears to have an appropriate entrance ramp and equipment has required playground transfer locations.
- Benches are not accessible.
- Tripping hazard where the plastic edging in the mulch is in the running area, though not likely in a safety zone.

GENERAL CONDITION COMMENTS

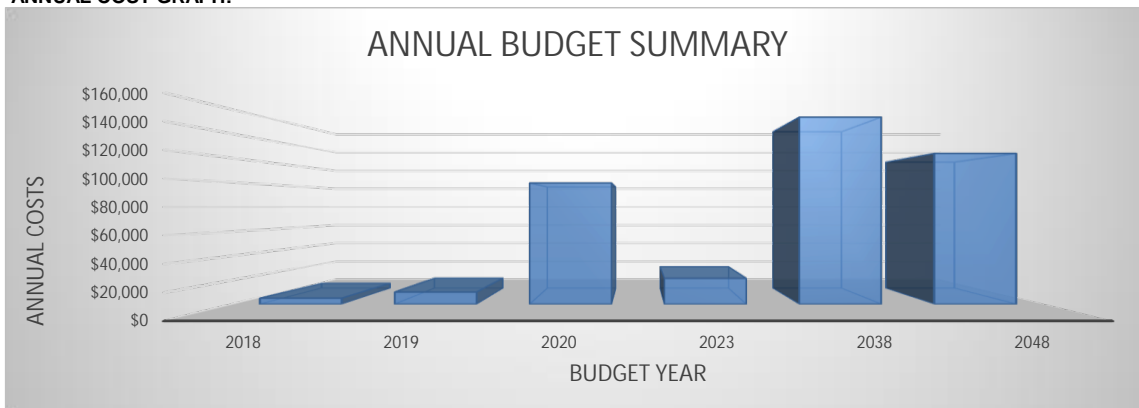
Score **2.50**

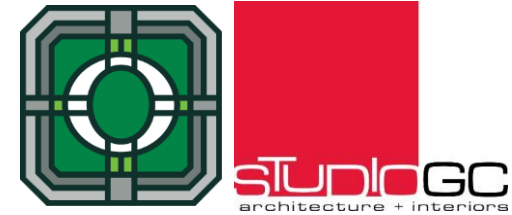
Park has deteriorated somewhat in alignment to the age. The ground playground equipment has deteriorated and is nearing the end of it's useful life.

- The pavilion patio has some trip hazards as the pavilion posts have settled.
- The edge restraint for the playground is plastic and is in need of replacement.
- Walkways are deteriorated and will be in need of replacement soon.
- Recommendation to remove sand pits, there are bees in numerous parks.

Score Average **3.02**

ANNUAL COST GRAPH:





COST BY BUDGET YEAR:

COLONIAL PARK

Budget Year	Component	Detail	Values	
			Sum of 2019 Replacement Cost	Sum of Escalated Budget
2018	SITE COMPONENTS	Concrete Patios	\$5,256.00	\$4,935.21
2018 Total			\$5,256.00	\$4,935.21
2019	Play Component	Ground Equipment	\$10,000.00	\$10,000.00
2019 Total			\$10,000.00	\$10,000.00
2020	PARK AMENITIES	Benches	\$3,000.00	\$3,195.00
		Trash/Recycling	\$400.00	\$426.00
	Play Component	Elevated Structures (2)	\$50,000.00	\$53,250.00
		Mulch	\$28,520.00	\$30,373.80
		Edge Restraint	\$11,704.00	\$12,464.76
2020 Total			\$93,624.00	\$99,709.56
2023	PARK AMENITIES	Pavilion	\$16,500.00	\$21,226.69
2023 Total			\$16,500.00	\$21,226.69
2038	SITE COMPONENTS	Concrete Walks	\$46,500.00	\$153,849.29
2038 Total			\$46,500.00	\$153,849.29
2048	SITE COMPONENTS	Landscaping	\$19,967.92	\$124,014.21
2048 Total			\$19,967.92	\$124,014.21
Grand Total			\$191,847.92	\$413,734.97

Description/Life Expectancy		Task	Installed Date	Service Life	Anticipated Replacement Date	General Conditions			Evaluated Condition			Estimated Cost Data - 2019						Comments		
Component	Detail		(year)	(years)	(year)	Security (1-5) <small>(0 is lowest)</small>	General (1-5) <small>(0 is lowest)</small>	Accessibility (1-5) <small>(0 is lowest)</small>	Evaluation Date <small>(year)</small>	Life Expectancy Modifier <small>%</small>	Life Expectancy Beyond Evaluation <small>(years remaining)</small> <small>(0 is lowest)</small>	Budget Year	Qty	Units	Prorate	Unit Cost	2019 Replacement Cost <small>(As of Evaluation date)</small>	Escalated Budget		
SITE COMPONENTS						4														
Site Components	Concrete Walks		1998	40	2038		4	3	2019	0%	0	2038	9,300	sf		\$5.00	\$46,500	\$153,849		
Site Components	Concrete Patios		1998	20	2018		2	3	2019	0%	0	2018	292	sf		\$18.00	\$5,256	\$4,935		
Site Components	Landscaping		1998	50	2048		3		2019	0%	0	2048	249,599	sf		\$0.08	\$19,968	\$124,014		
PLAY COMPONENTS																				
Play Component	Elevated Structures (2)		1998	15	2013		2	3	2019	45%	7	2020	2	each		\$25,000.00	\$50,000	\$53,250	See Accessibility Chart	
Play Component	Ground Equipment		1998	15	2013		2	3	2019	35%	5	2019	4	each		\$2,500.00	\$10,000	\$10,000	See Accessibility Chart	
Play Component	Mulch		2010	10	2020		4	3	2019	0%	0	2020	5,704	sf		\$5.00	\$28,520	\$30,374		
Play Component	Edge Restraint		1998	40	2038		1		2019	-45%	-18	2020	308	lf		\$38.00	\$11,704	\$12,465	Plastic Edging	
PARK AMENITIES																				
Park Amenities	Benches		1998	10	2008		3	1	2019	120%	12	2020	3	each		\$1,000.00	\$3,000	\$3,195		
Park Amenities	Trash/Recycling		1998	10	2008		2		2019	120%	12	2020	1	each		\$400.00	\$400	\$426		
Park Amenities	Pavilion		1998	25	2023		2	2	2019	0%	0	2023	165	sf		\$100.00	\$16,500	\$21,227		
RECREATION COMPONENTS																				
						4.00	2.50	2.57										\$191,848	\$413,735	

NOTES

Evaluation of building conditions focused on the elements likely to be included in the budget for items expected to require replacement or renovation within the next 10 to 15 years. Equipment, materials, or assemblies that are nominal in cost are not included. This is therefore not a comprehensive list but does identify major expenses that are likely to be incurred in the foreseeable future.

Conditions change with time, and this evaluation, along with the funds allocated to cover the associated expenses should be reviewed and revised periodically as the Department's needs evolve. Unanticipated expenses can develop for a number of reasons including accelerated use or changes in use patterns, accident, or deferred general maintenance. Such reviews should include updating baseline costs and dates for the components or assemblies identified in this study.

Costs are calculated at 2019 levels and escalated at the following presumed annual rate of inflation:

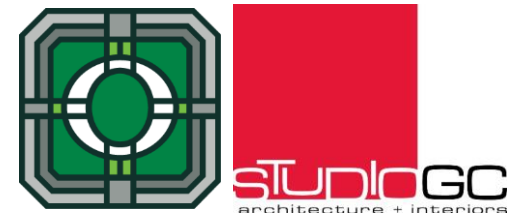
6.50% per annum

This report is broken up into different categories. The first three are organized by category with like expenses grouped together. The worksheets also covers Mechanical expenses, Electrical expenses, and Plumbing expenses. The last worksheet is organized by the computed year of expense (Budget Year).

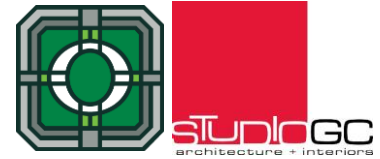
Repair/replacement work items do not include A/E Design Fees in the cost.

Total Combined Facilities

2018	\$4,935
2019	\$10,000
2020	\$99,710
2023	\$21,227
2038	\$153,849
2048	\$124,014
Total:	\$413,735



NAME: COUNTRY CLUB ESTATES
ADDRESS: 14449 Country Club Lane, Orland Park, IL 60462
PARK TYPE: Neighborhood
EVALUATION YEAR: 2019



PARK MAP:



PARK DATA:

Year Renovated:	1998
Park Age:	21
Total Acreage:	1.5
Total Parking Spaces:	0

Amenities:

Playground Equip: Gametime
 Bike/ Walking Path
 Pavilion

SECURITY COMMENTS:

- There are no security concerns. The park has good visibility from the public way.
- Maintain consistent trimming of landscape to maintain open visibility.
- Play area is not located near the roadway but is highly visible.
- Security lighting should be considered if law enforcement has concerns.

Score 3.50

ACCESSIBILITY COMMENTS

- Most features of the park were constructed prior to the 2010 Accessibility Code.
- Accessible ramps to the play surface appear to be compliant but not well located.
- There do not appear to be accessible tables at the pavilion.
- Playground equipment appears to be compliant but a full study should be completed.

Score 2.88

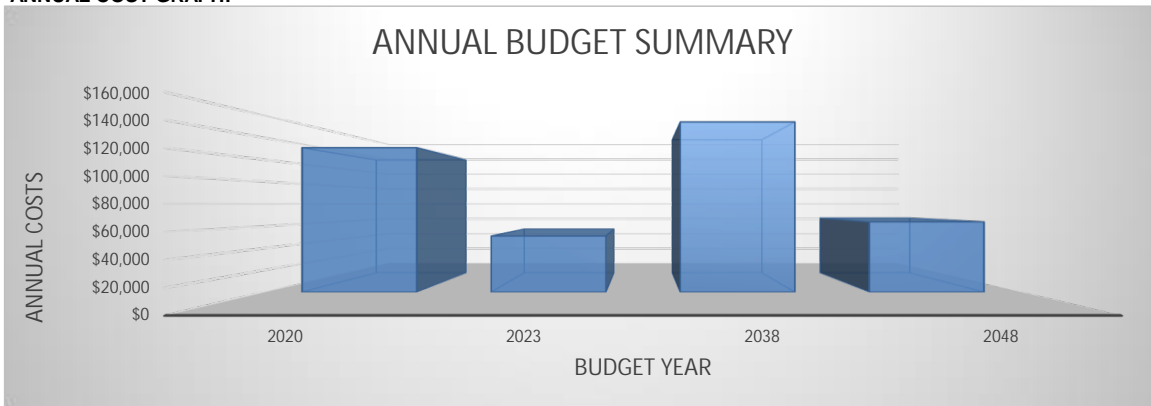
GENERAL CONDITION COMMENTS

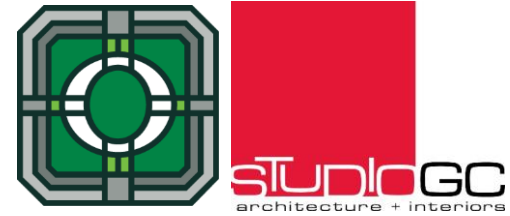
- Park is in good shape.
- Playground is in need of a replacement in the coming years.
- Concrete in edge restraint is in good shape for the age.
- Finishes are deteriorating but not to the point they are affecting activities.

Score 2.80

Score Average 3.06

ANNUAL COST GRAPH:





COST BY BUDGET YEAR:

COUNTRY CLUB ESTATES

Budget Year	Component	Detail	Values	
			Sum of 2019 Replacement Cost	Sum of Escalated Budget
2020	SITE COMPONENTS	Concrete Patios	\$22,014.00	\$23,444.91
		PARK AMENITIES	Benches	\$4,000.00
		Trash/Recycling	\$1,200.00	\$1,278.00
	Play Component	Elevated Structures (2)	\$50,000.00	\$53,250.00
		Ground Equipment	\$12,500.00	\$13,312.50
		Mulch	\$33,305.00	\$35,469.83
		Sand Play Area		
2020 Total			\$123,019.00	\$131,015.24
2023	PARK AMENITIES	Pavilion	\$39,595.20	\$50,937.89
2023 Total			\$39,595.20	\$50,937.89
2038	SITE COMPONENTS	Concrete Walks	\$29,025.00	\$96,031.74
	Play Component	Edge Restraint	\$17,632.00	\$58,337.00
2038 Total			\$46,657.00	\$154,368.74
2048	SITE COMPONENTS	Landscaping	\$10,258.35	\$63,711.25
2048 Total			\$10,258.35	\$63,711.25
Grand Total			\$219,529.55	\$400,033.12

Description/Life Expectancy		Task	Installed Date	Service Life	Anticipated Replacement Date	Assessments			Evaluated Condition			Estimated Cost Data - 2019						Comments	
Component	Detail		(year)	(years)	(year)	Security (1-5)	General (1-5)	Accessibility (1-5)	Evaluation Date	Life Expectancy Modifier	Life Expectancy Beyond Evaluation (years remaining)	Budget Year	Qty	Units	Prorate	Unit Cost	2019 Replacement Cost		Escalated Budget
						(0 is lowest)	(0 is lowest)	(0 is lowest)	(year)	%	(0 is lowest)						(As of Evaluation date)		
SITE COMPONENTS						4													
Site Components	Concrete Walks		1998	40	2038		3	3	2019	0%	0	2038	5,805	sf		\$5.00	\$29,025	\$96,032	
Site Components	Concrete Patios		1998	20	2018		3	3	2019	10%	2	2020	1,223	sf		\$18.00	\$22,014	\$23,445	
Site Components	Landscaping		1998	50	2048		3		2019	0%	0	2048	68,389	sf		\$0.15	\$10,258	\$63,711	
PLAY COMPONENTS																			
Play Component	Elevated Structures (2)		1998	15	2013		2	3	2019	45%	7	2020	2	each		\$25,000.00	\$50,000	\$53,250	See Accessibility Chart
Play Component	Ground Equipment		1998	15	2013		2	3	2019	45%	7	2020	5	each		\$2,500.00	\$12,500	\$13,313	See Accessibility Chart
Play Component	Mulch		2010	10	2020		3	4	2019	0%	0	2020	6,661	sf		\$5.00	\$33,305	\$35,470	
Play Component	Edge Restraint		1998	40	2038		4		2019	0%	0	2038	464	lf		\$38.00	\$17,632	\$58,337	Plastic Edging
Play Component	Sand Play Area		2010	10	2020				2019	0%	0	2020	264	sf		\$47.00			
PARK AMENITIES						3													
Park Amenities	Benches		1998	10	2008		3	1	2019	120%	12	2020	4	each		\$1,000.00	\$4,000	\$4,260	
Park Amenities	Trash/Recycling		1998	10	2008		3	3	2019	120%	12	2020	1	each		\$1,200.00	\$1,200	\$1,278	
Park Amenities	Pavilion		1998	25	2023		2	3	2019	0%	0	2023	396	sf		\$100.00	\$39,595	\$50,938	
						3.50	2.80	3									\$219,530	\$400,033	

NOTES

Evaluation of building conditions focused on the elements likely to be included in the budget for items expected to require replacement or renovation within the next 10 to 15 years. Equipment, materials, or assemblies that are nominal in cost are not included. This is therefore not a comprehensive list but does identify major expenses that are likely to be incurred in the foreseeable future.

Conditions change with time, and this evaluation, along with the funds allocated to cover the associated expenses should be reviewed and revised periodically as the Department's needs evolve. Unanticipated expenses can develop for a number of reasons including accelerated use or changes in use patterns, accident, or deferred general maintenance. Such reviews should include updating baseline costs and dates for the components or assemblies identified in this study.

Costs are calculated at 2019 levels and escalated at the following presumed annual rate of inflation:

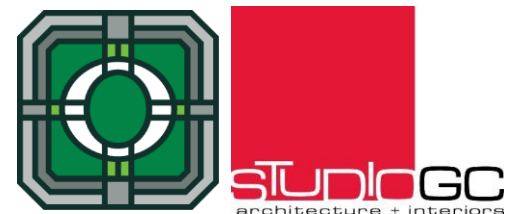
6.50% per annum

This report is broken up into different categories. The first three are organized by category with like expenses grouped together. The worksheets also covers Mechanical expenses, Electrical expenses, and Plumbing expenses. The last worksheet is organized by the computed year of expense (Budget Year).

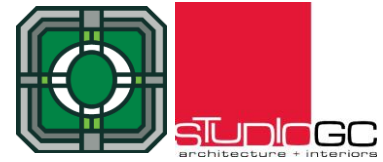
Repair/replacement work items do not include A/E Design Fees in the cost.

Total Combined Facilities

2020	\$131,015
2023	\$50,938
2038	\$154,369
2048	\$63,711
Total:	\$400,033



NAME: CRYSTAL CREEK PARK
ADDRESS: 16098 Laurel Dr, Orland Park, IL 60462
PARK TYPE: Mini
EVALUATION YEAR: 2019



PARK MAP:



PARK DATA:

Year Renovated:	1999
Park Age:	20
Total Acreage:	1.4
Total Parking Spaces:	0

Amenities:

Playground Equip: Landscape Structures

SECURITY COMMENTS:

- Park has no security concerns.
- Play area and park area is highly visible from public way.
- Consider security level lighting if needed.
- Play area is well located away from the road way.

Score 4.00

ACCESSIBILITY COMMENTS

- Play areas were constructed prior to the 2010 ADA Accessibility Code. A few items of note:
- Fiber Play surface is not accessible
- Condition of the PIP detracts from it's accessibility
- Play equipment has appropriate transfer stations.
- The sand area is not considered accessible.

Score 3.33

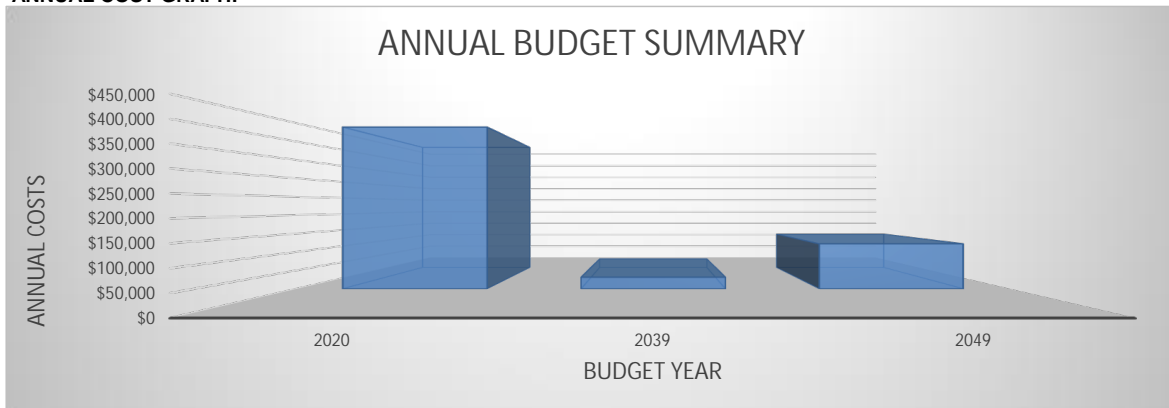
GENERAL CONDITION COMMENTS

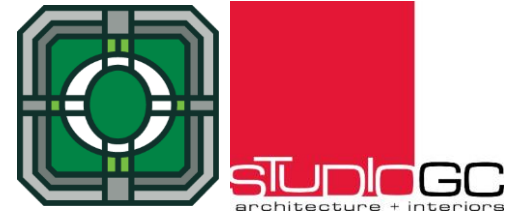
- The park is in reasonable condition given it's age.
- There is significant cosmetic deterioration which should be corrected before it becomes structural.
- The poured and play surface is deteriorated and needs to be replaced.

Score 2.33

Score Average 3.22

ANNUAL COST GRAPH:





COST BY BUDGET YEAR:

CRYSTAL CREEK PARK

Budget Year	Component	Detail	Values	
			Sum of 2019 Replacement Cost	Sum of Escalated Budget
2020	PARK AMENITIES	Benches	\$5,000.00	\$5,325.00
		Trash/Recycling	\$400.00	\$426.00
	Play Component	Elevated Structures (2)	\$50,000.00	\$53,250.00
		Ground Equipment	\$15,000.00	\$15,975.00
		Mulch	\$31,090.00	\$33,110.85
		Sand Play Area	\$292,246.00	\$311,241.99
		Edge Restraint	\$18,354.00	\$19,547.01
2020 Total			\$412,090.00	\$438,875.85
2039	SITE COMPONENTS	Concrete Walks	\$9,000.00	\$31,712.81
2039 Total			\$9,000.00	\$31,712.81
2049	SITE COMPONENTS	Landscaping	\$18,469.44	\$122,163.64
2049 Total			\$18,469.44	\$122,163.64
Grand Total			\$439,559.44	\$592,752.29

Description/Life Expectancy		Task	Installed Date	Service Life	Anticipated Replacement Date	Assessments			Evaluated Condition			Estimated Cost Data - 2019						Comments		
Component	Detail		(year)	(years)	(year)	Security (1-5) (0 is lowest)	General (1-5) (0 is lowest)	Accessibility (1-5) (0 is lowest)	Evaluation Date (year)	Life Expectancy Modifier %	Life Expectancy Beyond Evaluation (years remaining) (0 is lowest)	Budget Year	Qty	Units	Prorate	Unit Cost	2019 Replacement Cost (As of Evaluation date)	Escalated Budget		
SITE COMPONENTS						4														
Site Components	Concrete Walks		1999	40	2039		3		2019	0%	0	2039	1,800	sf		\$5.00	\$9,000	\$31,713		
Site Components	Landscaping		1999	50	2049		3		2019	0%	0	2049	46,174	sf		\$0.40	\$18,469	\$122,164		
PLAY COMPONENTS																				
Play Component	Elevated Structures (2)		1999	15	2014		2	4	2019	40%	6	2020	2	each		\$25,000.00	\$50,000	\$53,250	See Accessibility Chart	
Play Component	Ground Equipment		1999	15	2014		2	4	2019	40%	6	2020	6	each		\$2,500.00	\$15,000	\$15,975	See Accessibility Chart	
Play Component	Mulch		2010	10	2020		1	3	2019	0%	0	2020	6,218	sf		\$5.00	\$31,090	\$33,111		
Play Component	Sand Play Area		2010	10	2020		1	1	2019	0%	0	2020	6,218	sf		\$47.00	\$292,246	\$311,242		
Play Component	Edge Restraint		1999	41	2040		3		2019	-50%	-21	2020	483	lf		\$38.00	\$18,354	\$19,547	Plastic Edging	
PARK AMENITIES																				
Park Amenities	Benches		1999	10	2009		3	4	2019	110%	11	2020	5	each		\$1,000.00	\$5,000	\$5,325		
Park Amenities	Trash/Recycling		1999	10	2009		3	4	2019	110%	11	2020	1	each		\$400.00	\$400	\$426		
						4.00	2.33	3.33									\$439,559	\$592,752		

NOTES

Evaluation of building conditions focused on the elements likely to be included in the budget for items expected to require replacement or renovation within the next 10 to 15 years. Equipment, materials, or assemblies that are nominal in cost are not included. This is therefore not a comprehensive list but does identify major expenses that are likely to be incurred in the foreseeable future.

Conditions change with time, and this evaluation, along with the funds allocated to cover the associated expenses should be reviewed and revised periodically as the Department's needs evolve. Unanticipated expenses can develop for a number of reasons including accelerated use or changes in use patterns, accident, or deferred general maintenance. Such reviews should include updating baseline costs and dates for the components or assemblies identified in this study.

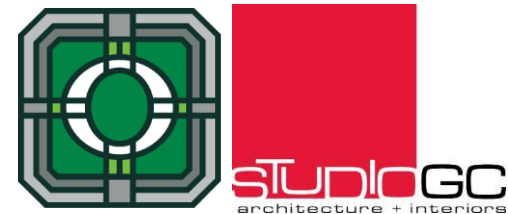
Costs are calculated at 2019 levels and escalated at the following presumed annual rate of inflation:

6.50% per annum

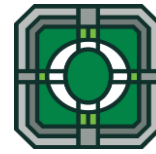
This report is broken up into different categories. The first three are organized by category with like expenses grouped together. The worksheets also covers Mechanical expenses, Electrical expenses, and Plumbing expenses. The last worksheet is organized by the computed year of expense (Budget Year).

Repair/replacement work items do not include A/E Design Fees in the cost.

Total Combined Facilities	
2020	\$438,876
2039	\$31,713
2049	\$122,164
Total:	\$592,752



NAME: DEER HAVEN PARK
ADDRESS: 11011 Deer Haven Lane, Orland Park IL
PARK TYPE: Neighborhood
EVALUATION YEAR: 2019



PARK MAP:



PARK DATA:

Year Renovated:	2018
Park Age:	1
Total Acreage:	3.07
Total Parking Spaces:	0

Amenities:

Playground Equip: Landscape Struct.
 Pavilion

SECURITY COMMENTS:

Score **4.00**

Park security is as to be expected for this size facility. See a few specific areas of note and one concern:

- Great visibility from public ways
- Security lighting should be considered if law enforcement has concerns.

ACCESSIBILITY COMMENTS

Score **3.00**

The park was constructed after the 2010 Accessibility Guidelines and appears to be in compliance. A few items to verify:

- Pathways are wide to accommodate all users
- Slight concern over the transition ramp from the sidewalk into the fiber play surface. It does not taper below the play surface material as it should.

GENERAL CONDITION COMMENTS

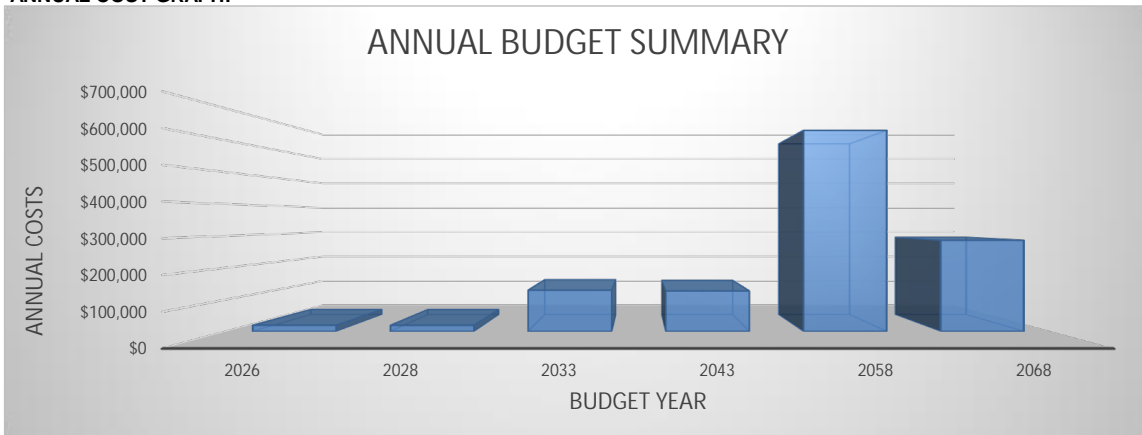
Score **4.36**

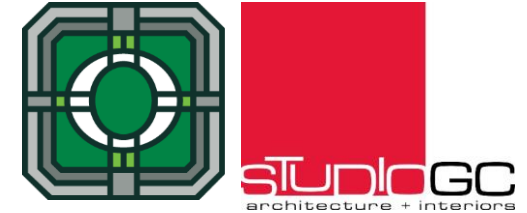
The park is in very good condition.

- No signs of finish deterioration
- Play surface is in very good condition and appears to have been recently refreshed.

Score Average **3.79**

ANNUAL COST GRAPH:





COST BY BUDGET YEAR:

DEER HAVEN PARK

Budget Year	Component	Detail	Values	
			Sum of 2019 Replacement Cost	Sum of Escalated Budget
2026	Play Component	Fiber Play Surface	\$12,500.00	\$19,424.83
2026 Total			\$12,500.00	\$19,424.83
2028	PARK AMENITIES	Benches	\$2,000.00	\$3,525.14
		Trash/Recycling	\$400.00	\$705.03
		Fencing (Vinyl)	\$8,500.00	\$14,981.85
2028 Total			\$10,900.00	\$19,212.02
2033	Play Component	Elevated Structures (2)	\$50,000.00	\$120,743.71
		Ground Equipment	\$3,600.00	\$8,693.55
2033 Total			\$53,600.00	\$129,437.26
2043	PARK AMENITIES	Pavilion	\$28,000.00	\$126,925.42
2043 Total			\$28,000.00	\$126,925.42
2058	SITE COMPONENTS	Concrete Walks	\$34,000.00	\$396,381.72
		Concrete Patio	\$9,486.00	\$110,590.50
	Play Component	Edge Restraint	\$10,640.00	\$124,044.16
2058 Total			\$54,126.00	\$631,016.39
2068	SITE COMPONENTS	Landscaping	\$13,068.0	\$285,982.8
2068 Total			\$13,068.00	\$285,982.80
Grand Total			\$172,194.00	\$1,211,998.71

Description/Life Expectancy		Task	Installed Date	Service Life	Anticipated Replacement Date	Assessments			Evaluated Condition			Estimated Cost Data - 2019					Comments			
Component	Detail		(year)	(years)	(year)	Security (1-5)	General (1-5)	Accessibility (1-5)	Evaluation Date	Life Expectancy Modifier	Life Expectancy Beyond Evaluation (years remaining)	Budget Year	Qty	Units	Prorate	Unit Cost	2019 Replacement Cost	Escalated Budget		
						(0 is lowest)	(0 is lowest)	(0 is lowest)	(year)	%	(0 is lowest)						(As of Evaluation date)			
SITE COMPONENTS						4														
Site Components	Concrete Walks		2018	40	2058		5	3	2019	0%	0	2058	6,800	sf		\$5.00	\$34,000	\$396,382		
Site Components	Concrete Patio		2018	40	2058		4	3	2019	0%	0	2058	527	sf		\$18.00	\$9,486	\$110,591		
Site Components	Landscaping		2018	50	2068		5		2019	0%	0	2068	130,680	sf		\$0.10	\$13,068	\$285,983		
PLAY COMPONENTS																				
Play Component	Elevated Structures (2)		2018	15	2033		4	3	2019	0%	0	2033	2	each		\$25,000.00	\$50,000	\$120,744	See Accessibility Chart	
Play Component	Ground Equipment		2018	15	2033		4	3	2019	0%	0	2033	3	each		\$1,200.00	\$3,600	\$8,694	See Accessibility Chart	
Play Component	Fiber Play Surface		2018	8	2026		5	3	2019	0%	0	2026	2,500	sf		\$5.00	\$12,500	\$19,425		
Play Component	Edge Restraint		2018	40	2058		5		2019	0%	0	2058	280	lf		\$38.00	\$10,640	\$124,044	Plastic Edging	
PARK AMENITIES																				
Park Amenities	Pavilion		2018	25	2043		4	3	2019	0%	0	2043	280	sf		\$100.00	\$28,000	\$126,925		
Park Amenities	Benches		2018	10	2028		4	3	2019	0%	0	2028	2	each		\$1,000.00	\$2,000	\$3,525		
Park Amenities	Trash/Recycling		2018	10	2028		4		2019	0%	0	2028	1	each		\$400.00	\$400	\$705		
Park Amenities	Fencing (Vinyl)		2018	10	2028		4		2019	0%	0	2028	85	lf		\$100.00	\$8,500	\$14,982		
RECREATION COMPONENTS																				
						4.00	4.36	3.00										\$172,194	\$1,211,999	

NOTES

Evaluation of building conditions focused on the elements likely to be included in the budget for items expected to require replacement or renovation within the next 10 to 15 years. Equipment, materials, or assemblies that are nominal in cost are not included. This is therefore not a comprehensive list but does identify major expenses that are likely to be incurred in the foreseeable future.

Conditions change with time, and this evaluation, along with the funds allocated to cover the associated expenses should be reviewed and revised periodically as the department's needs evolve. Unanticipated expenses can develop for a number of reasons including accelerated use or changes in use patterns, accident, or deferred general maintenance. Such reviews should include updating baseline costs and dates for the components or assemblies identified in this study.

Costs are calculated at 2019 levels and escalated at the following presumed annual rate of inflation:

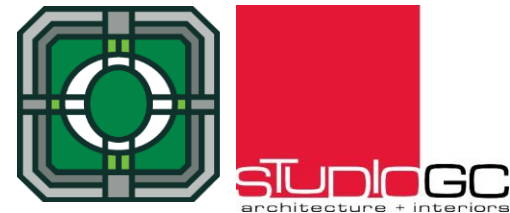
6.50% per annum

This report is broken up into different categories. The first three are organized by category with like expenses grouped together. The worksheets also covers Mechanical expenses, Electrical expenses, and Plumbing expenses. The last worksheet is organized by the computed year of expense (Budget Year).

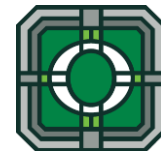
Repair/replacement work items do not include A/E Design Fees in the cost.

Total Combined Facilities

2026	\$19,425
2028	\$19,212
2033	\$129,437
2043	\$126,925
2058	\$631,016
2068	\$285,983
Total:	\$1,211,999



NAME: DEER POINT PARK
ADDRESS: 17300 Deer Point Dr, Orland Park, IL 60462
PARK TYPE: Neighborhood
EVALUATION YEAR: 2019



PARK MAP:



PARK DATA:

Year Renovated:	2000
Park Age:	19
Total Acreage:	5.1
Total Parking Spaces:	0

Amenities:

Playground Equip:	Landscape Struct.
Bean Bag Boards	
Bike/ Walking Path	
Drinking Fountain	
Handicap Swing	
Pavilion	

SECURITY COMMENTS:

- Park has no security concerns.
- Play area and park area is highly visible from public way.
- Consider security level lighting if needed.
- Play area is well located away from the road way.

Score **4.00**

ACCESSIBILITY COMMENTS

- Play areas were constructed prior to the 2010 ADA Accessibility Code. A few items of note:
- Fiber Play surface is not accessible
- Condition of the PIP detracts from it's accessibility
- Play equipment has appropriate transfer stations.
- The sand area is not considered accessible.

Score **3.29**

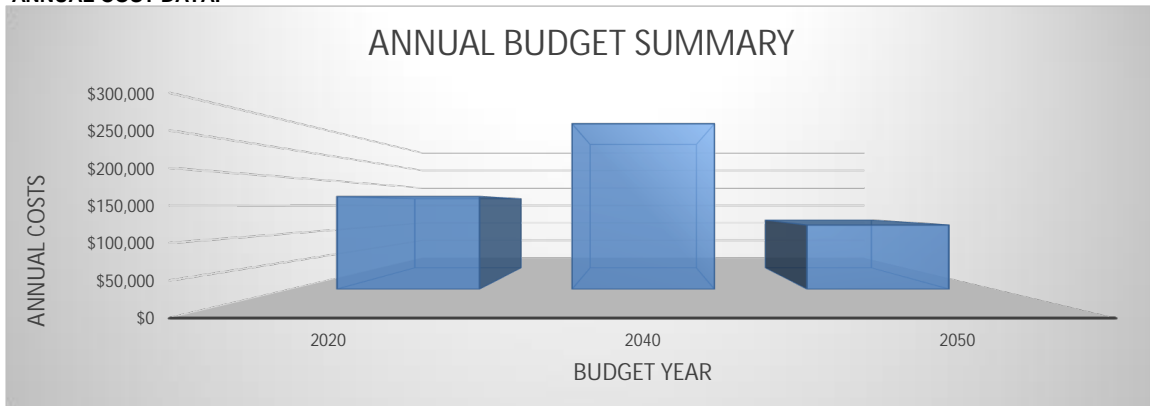
GENERAL CONDITION COMMENTS

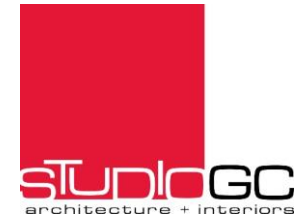
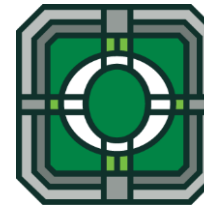
- The park is in reasonable condition given it's age.
- There is significant cosmetic deterioration which should be corrected before it becomes structural.
- The sand pit is detrimental to the overall condition of the park and is attracting nuisance insects.

Score **2.86**

Score Average **3.38**

ANNUAL COST DATA:





COST BY BUDGET YEAR:

DEER POINT PARK

Budget Year	Component	Detail	Values	
			Sum of 2019 Replacement Cost	Sum of Escalated Budget
2020	SITE COMPONENTS	Concrete Patios	\$49,572.00	\$52,794.18
		PARK AMENITIES	Benches	\$4,000.00
		Trash/Recycling	\$400.00	\$426.00
	Play Component	Elevated Structures (2)	\$62,500.00	\$66,562.50
		Ground Equipment	\$10,000.00	\$10,650.00
		Mulch	\$29,290.00	\$31,193.85
2020 Total			\$155,762.00	\$165,886.53
2040	SITE COMPONENTS	Concrete Walks	\$64,125.00	\$240,640.73
	Play Component	Edge Restraint	\$14,820.00	\$55,614.75
2040 Total			\$78,945.00	\$296,255.48
2050	SITE COMPONENTS	Landscaping	\$16,308.86	\$114,884.53
2050 Total			\$16,308.86	\$114,884.53
Grand Total			\$251,015.86	\$577,026.54

Description/Life Expectancy		Task	Installed Date	Service Life	Anticipated Replacement Date	Assessment			Evaluated Condition			Estimated Cost Data - 2019						Comments		
Component	Detail		(year)	(years)	(year)	Security (1-5)	General (1-5)	Accessibility (1-5)	Evaluation Date	Life Expectancy Modifier	Life Expectancy Beyond Evaluation (years remaining)	Budget Year	Qty	Units	Prorate	Unit Cost	2019 Replacement Cost	Escalated Budget		
						(0 is lowest)	(0 is lowest)	(0 is lowest)	(year)	%	(0 is lowest)						(As of Evaluation date)			
SITE COMPONENTS						4														
Site Components	Concrete Walks		2000	40	2040		2	3	2019	0%	0	2040	12,825	sf		\$5.00	\$64,125	\$240,641		
Site Components	Concrete Patios		2000	20	2020		4	3	2019	0%	0	2020	2,754	sf		\$18.00	\$49,572	\$52,794		
Site Components	Landscaping		2000	50	2050				2019	0%	0	2050	203,861	sf		\$0.08	\$16,309	\$114,885		
PLAY COMPONENTS						4														
Play Component	Elevated Structures (2)		2000	15	2015		2	3	2019	30%	5	2020	3	each		\$25,000.00	\$62,500	\$66,563	See Accessibility Chart	
Play Component	Ground Equipment		2000	15	2015		2	3	2019	30%	5	2020	4	each		\$2,500.00	\$10,000	\$10,650	See Accessibility Chart	
Play Component	Mulch		2010	10	2020			3	2019	0%	0	2020	5,858	sf		\$5.00	\$29,290	\$31,194		
Play Component	Edge Restraint		2000	40	2040		3		2019	0%	0	2040	390	lf		\$38.00	\$14,820	\$55,615	Plastic Edging	
PARK AMENITIES						4														
Park Amenities	Benches		2000	10	2010		4	4	2019	100%	10	2020	4	each		\$1,000.00	\$4,000	\$4,260		
Park Amenities	Trash/Recycling		2000	10	2010		3	4	2019	100%	10	2020	1	each		\$400.00	\$400	\$426		
						4.00	2.86	3.29												
																	\$251,016	\$577,027		

NOTES

Evaluation of building conditions focused on the elements likely to be included in the budget for items expected to require replacement or renovation within the next 10 to 15 years. Equipment, materials, or assemblies that are nominal in cost are not included. This is therefore not a comprehensive list but does identify major expenses that are likely to be incurred in the foreseeable future.

Conditions change with time, and this evaluation, along with the funds allocated to cover the associated expenses should be reviewed and revised periodically as the department's needs evolve. Unanticipated expenses can develop for a number of reasons including accelerated use or changes in use patterns, accident, or deferred general maintenance. Such reviews should include updating baseline costs and dates for the components or assemblies identified in this study.

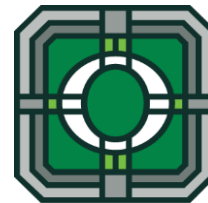
Costs are calculated at 2019 levels and escalated at the following presumed annual rate of inflation:

6.50% per annum

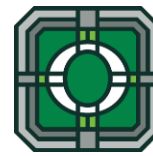
This report is broken up into different categories. The first three are organized by category with like expenses grouped together. The worksheets also covers Mechanical expenses, Electrical expenses, and Plumbing expenses. The last worksheet is organized by the computed year of expense (Budget Year).

Repair/replacement work items do not include A/E Design Fees in the cost.

Total Combined Facilities	
2020	\$165,887
2040	\$296,255
2050	\$114,885
Total:	\$577,027



NAME: DISCOVERY PARK
ADDRESS: 11501 Brookhill Dr, Orland Park, IL 60462
PARK TYPE: Neighborhood
EVALUATION YEAR: 2019



PARK MAPS:



PARK DATA:

Year Renovated:	2000
Park Age:	19
Total Acreage:	11.6
Total Parking Spaces:	24

Amenities:

Playground	Little Tykes
Baseball/Softball Field	1
Basketball Court	1
Bike/ Walking Path	
Bocce Ball	2
Drinking Fountain	
Horseshoes	
Pavilion	
Pickleball	
Picnic Grills	
Tennis Court	1
Soccer Fields	2

SECURITY COMMENTS:

- The park elements are somewhat isolated from the public way without good visibility.
- The pavilion is almost entirely isolated from adjacent visibility.
- Lighting should be considered given the location and how far apart the elements are.

Score **2.00**

ACCESSIBILITY COMMENTS

- The deterioration of the surfaces is significantly effecting the accessibility of the park.
- The play equipment was constructed prior to the 2010 ADA Code. Play equipment has transfer stations but a full analysis should be undertaken.
- The accessible path to the play surface seems to be via the PIP. This should be excavated to verify it provides an adequate transition.

Score **2.22**

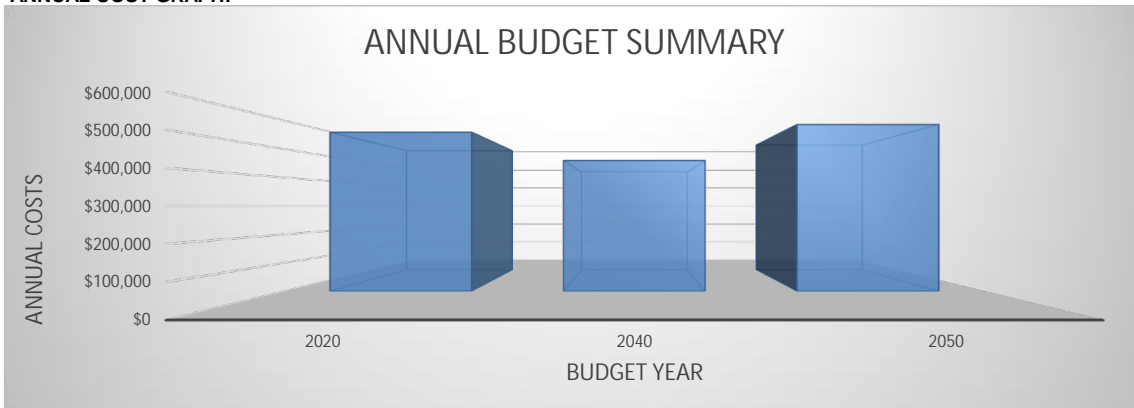
GENERAL CONDITION COMMENTS

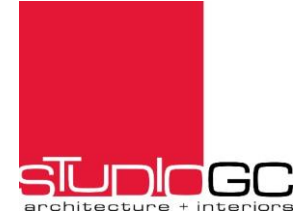
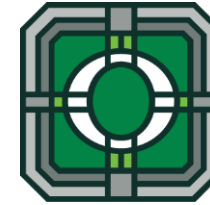
- The park is somewhat deteriorated more than would be anticipated for it's age.
- There is a concrete edge restraint that is a potential tripping hazard.
- The bocce ball courts need updating.
- The basketball court is significantly deteriorated and need of replacement.
- Fibar is washing out indicating grading and drainage issues.

Score **1.83**

Score Average **2.02**

ANNUAL COST GRAPH:





COST BY BUDGET YEAR:

DISCOVERY PARK
585864.9041

Budget Year	Component	Detail	Values		
			Sum of 2019 Replacement Cost	Sum of Escalated Budget	
2020	PARK AMENITIES	Benches	\$4,000.00	\$4,260.00	
		Park Lighting	\$10,000.00	\$10,650.00	
		Trash/Recycling	\$1,200.00	\$1,278.00	
		Bike Racks/Systems	\$1,200.00	\$1,278.00	
		Drinking Fountains	\$3,000.00	\$3,195.00	
		Play Component	Elevated Structures (2)	\$100,000.00	\$106,500.00
			Ground Equipment	\$7,500.00	\$7,987.50
			Mulch	\$48,850.00	\$52,025.25
			Sand Play Area	\$10,951.00	\$11,662.82
			Edge Restraint	\$27,854.00	\$29,664.51
			PIP Area	\$50,442.00	\$53,720.73
		RECREATION COMPONENTS	Basketball Courts	\$115,000.00	\$122,475.00
			Tennis Court	\$135,000.00	\$143,775.00
			Soccer Goals (practice)	\$10,000.00	\$10,650.00
2020 Total			\$524,997.00	\$559,121.81	
2040	SITE COMPONENTS	Concrete Walks	\$122,525.00	\$459,797.36	
2040 Total			\$122,525.00	\$459,797.36	
2050	SITE COMPONENTS	Landscaping	\$48,168.65	\$339,314.41	
	RECREATION COMPONENTS	Baseball Field	\$35,000.00	\$246,550.50	
2050 Total			\$83,168.65	\$585,864.90	
Grand Total			\$730,690.65	\$1,604,784.07	

Description/Life Expectancy		Task	Installed Date	Service Life	Anticipated Replacement Date	Assessments			Evaluated Condition			Estimated Cost Data - 2019					Comments		
Component	Detail		(year)	(years)	(year)	Security (1-5)	General (1-5)	Accessibility (1-5)	Evaluation Date	Life Expectancy Modifier	Life Expectancy Beyond Evaluation (years remaining)	Budget Year	Qty	Units	Prorate	Unit Cost		2019 Replacement Cost	Escalated Budget
						(0 is lowest)	(0 is lowest)	(0 is lowest)	(year)	%	(0 is lowest)							(As of Evaluation date)	
SITE COMPONENTS																			
Site Components	Concrete Walks		2000	40	2040		2		2019	0%	0	2040	24,505	sf		\$5.00	\$122,525	\$459,797	
Site Components	Landscaping		2000	50	2050				2019	0%	0	2050	802,811	sf		\$0.06	\$48,169	\$339,314	
PLAY COMPONENTS																			
Play Component	Elevated Structures (2)		2000	15	2015		2	3	2019	30%	5	2020	4	each		\$25,000.00	\$100,000	\$106,500	See Accessibility Chart
Play Component	Ground Equipment		2000	15	2015		2	3	2019	30%	5	2020	3	each		\$2,500.00	\$7,500	\$7,988	See Accessibility Chart
Play Component	Mulch		2010	10	2020		3	3	2019	0%	0	2020	9,770	sf		\$5.00	\$48,850	\$52,025	
Play Component	Sand Play Area		2010	10	2020		1	1	2019	0%	0	2020	233	sf		\$47.00	\$10,951	\$11,663	
Play Component	PIP Area		2010	10	2020		1	4	2019	0%	0	2020	1,201	sf		\$42.00	\$50,442	\$53,721	
Play Component	Edge Restraint		2000	40	2040		2		2019	-50%	-20	2020	733	lf		\$38.00	\$27,854	\$29,665	Plastic Edging
PARK AMENITIES																			
Park Amenities	Park Lighting		2000	20	2020				2019	0%	0	2020	4	each		\$2,500.00	\$10,000	\$10,650	
Park Amenities	Benches		2000	10	2010		2	1	2019	100%	10	2020	4	each		\$1,000.00	\$4,000	\$4,260	
Park Amenities	Trash/Recycling		2000	10	2010				2019	100%	10	2020	1	each		\$1,200.00	\$1,200	\$1,278	
Park Amenities	Bike Racks/Systems		2000	10	2010				2019	100%	10	2020	1	each		\$1,200.00	\$1,200	\$1,278	
Park Amenities	Drinking Fountains		2000	15	2015				2019	30%	5	2020	1	each		\$3,000.00	\$3,000	\$3,195	
RECREATION COMPONENTS																			
Recreation Components	Basketball Courts		2000	20	2020		1	1	2019	0%	0	2020	1	each		\$115,000.00	\$115,000	\$122,475	
Recreation Components	Baseball Field		2000	50	2050		2	1	2019	0%	0	2050	1	each		\$35,000.00	\$35,000	\$246,550	
Recreation Components	Tennis Court		2000	20	2020		3	3	2019	0%	0	2020	1	each		\$135,000.00	\$135,000	\$143,775	
Recreation Components	Soccer Goals (practice)		2000	5	2005		1		2019	290%	15	2020	2	each		\$5,000.00	\$10,000	\$10,650	
Recreation Components	Bocce Ball		2000										2	each		\$0.00	\$0	\$0	
																	\$720,691	\$1,594,134	

NOTES

Evaluation of building conditions focused on the elements likely to be included in the budget for items expected to require replacement or renovation within the next 10 to 15 years. Equipment, materials, or assemblies that are nominal in cost are not included. This is therefore not a comprehensive list but does identify major expenses that are likely to be incurred in the foreseeable future.

Conditions change with time, and this evaluation, along with the funds allocated to cover the associated expenses should be reviewed and revised periodically as the districts' needs evolve. Unanticipated expenses can develop for a number of reasons including accelerated use or changes in use patterns, accident, or deferred general maintenance. Such reviews should include updating baseline costs and dates for the components or assemblies identified in this study.

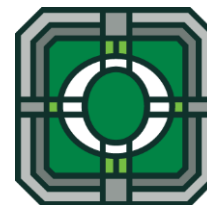
Costs are calculated at 2019 levels and escalated at the following presumed annual rate of inflation:

6.50% per annum

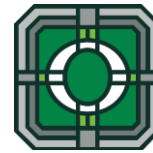
This report is broken up into different categories. The first three are organized by category with like expenses grouped together. The worksheets also covers Mechanical expenses, Electrical expenses, and Plumbing expenses. The last worksheet is organized by the computed year of expense (Budget Year).

Repair/replacement work items do not include A/E Design Fees in the cost.

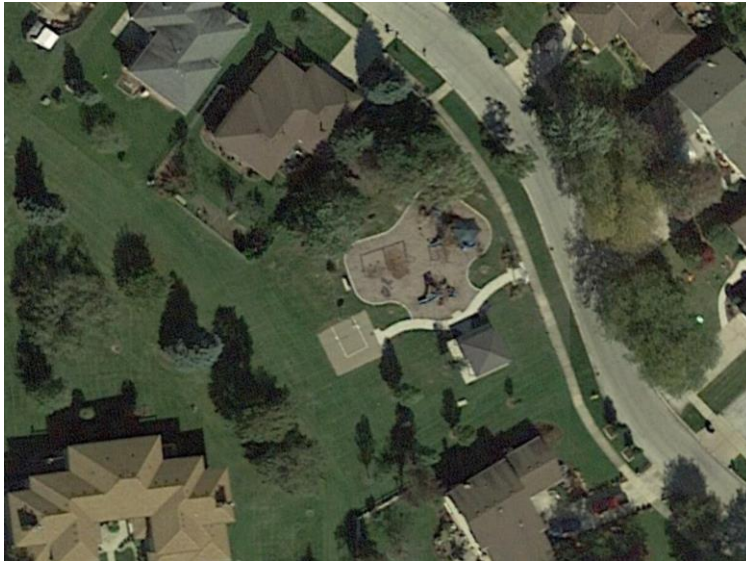
Total Combined Facilities	
2020	\$559,122
2040	\$459,797
2050	\$585,865
Total:	\$1,604,784



NAME: DOGWOOD PARK
ADDRESS: 14946 Dogwood Dr, Orland Park, IL 60462
PARK TYPE: Neighborhood
EVALUATION YEAR: 2019



PARK MAPS:



PARK DATA:

Year Renovated:	2016
Park Age:	3
Total Acreage:	11.6
Total Parking Spaces:	0

Amenities:

Playground	Gametime
Basketball Court	1
Bean Bag Boards	
Pavilion	

SECURITY COMMENTS:

- There are no security concerns at the park.
- There is good visibility from the road for all park elements
- Security lighting should be considered if law enforcement has concerns.

Score **3.00**

ACCESSIBILITY COMMENTS

Park is newly constructed and appears to meet current accessibility requirements.

Score **3.10**

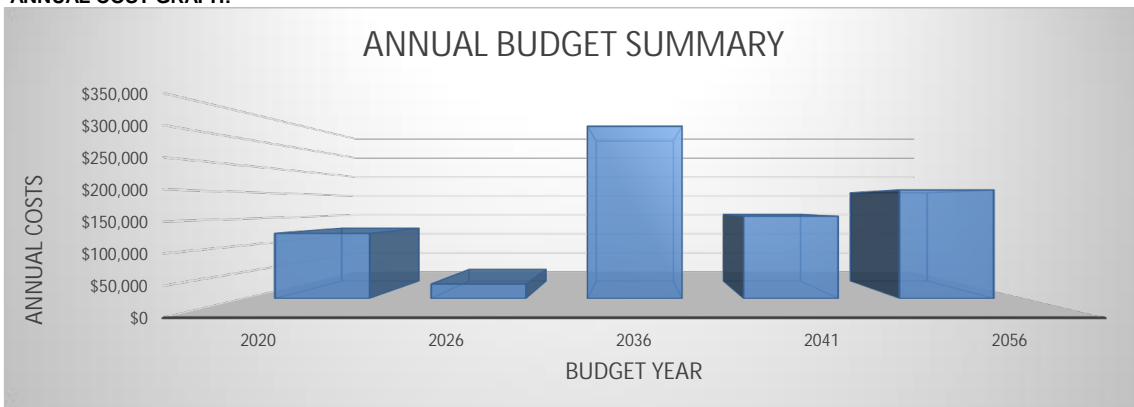
GENERAL CONDITION COMMENTS

- Play area is in fantastic condition due to it essentially being new construction.
- However the basketball court has some significant deterioration.

Score **4.64**

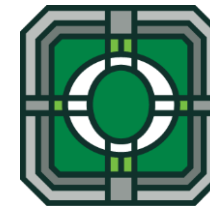
Score Average 3.58

ANNUAL COST GRAPH:



COST BY BUDGET YEAR:

DOGWOOD PARK



Budget Year	Component	Detail	Values	
			Sum of 2019 Replacement Cost	Sum of Escalated Budget
2020	RECREATION COMPONENT	Basketball Courts	\$115,000.0	\$122,475.0
2020 Total			\$115,000.0	\$122,475.0
2026	Play Component	Mulch	\$17,530.0	\$27,241.4
2026 Total			\$17,530.0	\$27,241.4
2036	SITE COMPONENTS PARK AMENITIES	Concrete Patios	\$10,836.0	\$31,609.1
		Benches	\$4,000.0	\$11,668.2
		Trash/Recycling	\$400.0	\$1,166.8
		Drinking fountain		\$6,500.0
	Play Component	Elevated Structures (2)	\$75,000.0	\$218,778.5
		Ground Equipment	\$5,000.0	\$14,585.2
		Edge Restraint	\$9,234.0	\$26,936.0
2036 Total			\$110,970.0	\$323,704.6
2041	PARK AMENITIES	Pavilion	\$38,700.0	\$154,668.7
2041 Total			\$38,700.0	\$154,668.7
2056	SITE COMPONENTS	Concrete Walks	\$7,225.0	\$74,263.1
		Landscaping	\$12,632.4	\$129,843.8
2056 Total			\$19,857.4	\$204,107.0
Grand Total			\$302,057.4	\$832,196.7

DOGWOOD PARK		14946 Dogwood Dr, Orland Park, IL 60462				Assessments			Evaluated Condition			Estimated Cost Data - 2019						Comments	
Description/Life Expectancy		Task	Installed Date	Service Life	Anticipated Replacement Date	Security (1-5)	General (1-5)	Accessibility (1-5)	Evaluation Date	Life Expectancy Modifier	Life Expectancy Beyond Evaluation (years remaining)	Budget Year	Qty	Units	Prorate	Unit Cost	2019 Replacement Cost		Escalated Budget
Component	Detail		(year)	(years)	(year)	(0 is lowest)	(0 is lowest)	(0 is lowest)	(year)	%	(0 is lowest)						(As of Evaluation date)		
SITE COMPONENTS						3													
Site Components	Concrete Walks		2016	40	2056		5	3	2019	0%	0	2056	1,445	sf		\$5.00	\$7,225	\$74,263	
Site Components	Concrete Patios		2016	20	2036		5	3	2019	0%	0	2036	602	sf		\$18.00	\$10,836	\$31,609	
Site Components	Landscaping		2000	50	2050				2019	12%	6	2056	25,265	sf		\$0.50	\$12,632	\$129,844	
PLAY COMPONENTS																			
Play Component	Elevated Structures (2)		2016	15	2031		5	4	2019	35%	5	2036	3	each		\$25,000.00	\$75,000	\$218,778	See Accessibility Chart
Play Component	Ground Equipment		2016	15	2031		5	4	2019	35%	5	2036	2	each		\$2,500.00	\$5,000	\$14,585	See Accessibility Chart
Play Component	Mulch		2016	10	2026		5	4	2019	0%	0	2026	3,506	sf		\$5.00	\$17,530	\$27,241	
Play Component	Edge Restraint		2016	40	2056		5		2019	-50%	-20	2036	243	lf		\$38.00	\$9,234	\$26,936	Plastic Edging
PARK AMENITIES																			
Park Amenities	Benches		2016	10	2026		5	2	2019	100%	10	2036	4	each		\$1,000.00	\$4,000	\$11,668	
Park Amenities	Drinking fountain		2016	10	2026		5	3	2019	100%	10	2036	1	each		\$6,500.00	\$6,500	\$18,961	
Park Amenities	Trash/Recycling		2016	10	2026		5	3	2019	100%	10	2036	1	each		\$400.00	\$400	\$1,167	
Park Amenities	Pavilion		2016	25	2041		5	3	2019	0%	0	2041	387	sf		\$100.00	\$38,700	\$154,669	
RECREATION COMPONENTS																			
Recreation Components	Basketball Courts		2000	20	2020		1	2	2019	0%	0	2020	1	each		\$115,000.00	\$115,000	\$122,475	
						3.00	4.64	3.10							\$302,057	\$832,197			

NOTES

Evaluation of building conditions focused on the elements likely to be included in the budget for items expected to require replacement or renovation within the next 10 to 15 years. Equipment, materials, or assemblies that are nominal in cost are not included. This is therefore not a comprehensive list but does identify major expenses that are likely to be incurred in the foreseeable future.

Conditions change with time, and this evaluation, along with the funds allocated to cover the associated expenses should be reviewed and revised periodically as the Department's needs evolve. Unanticipated expenses can develop for a number of reasons including accelerated use or changes in use patterns, accident, or deferred general maintenance. Such reviews should include updating baseline costs and dates for the components or assemblies identified in this study.

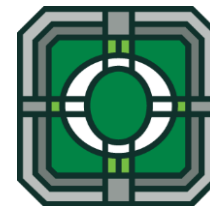
Costs are calculated at 2019 levels and escalated at the following presumed annual rate of inflation:

6.50% per annum

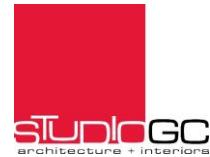
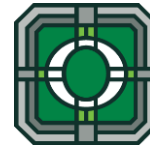
This report is broken up into different categories. The first three are organized by category with like expenses grouped together. The worksheets also covers Mechanical expenses, Electrical expenses, and Plumbing expenses. The last worksheet is organized by the computed year of expense (Budget Year).

Repair/replacement work items do not include A/E Design Fees in the cost.

Total Combined Facilities	
2020	\$122,475
2026	\$27,241
2036	\$323,705
2041	\$154,669
2056	\$204,107
Total:	\$832,197



NAME: DOOGAN PARK
ADDRESS: 14700 Park Lane, Orland Park
PARK TYPE: Community
EVALUATION YEAR: 2019



PARK MAP:



PARK DATA:

Year Renovated:	1999
Total Acreage:	17
Total Parking Spaces:	20+

Amenities:

Playground Equip:	Gametime/Tykes
Baseball/Softball Field	1
Basketball Courts	1
Bean Bag Boards	
Drinking Fountain	
Frisbee Golf	
Pavilion	
Pickleball	
Grills	
Tennis Courts	2
Bocce	

SECURITY COMMENTS:

Park security is as to be expected for this size facility. See a few specific areas of note and one concern:

- Great visibility from public ways
- Pathways have limited lighting but along play areas.
- There is an older unused play area (likely an old sand pit) that has a concrete curb. It is in the play area and could be considered a trip hazard.

Score **3.00**

ACCESSIBILITY COMMENTS

This park is more accessible than would be expected for it's age.

- The sand area is not accessible for play.
- Sidewalks provide a good level of accessibility and are generally free from heaving.
- Playground equipment will require additional evaluation to determine ADA compliance
- The tennis court access has a lip that exceeds tolerances
- The baseball field has a paved path to the spectator areas but it exceeds the allowable slope

Score **2.67**

GENERAL CONDITION COMMENTS

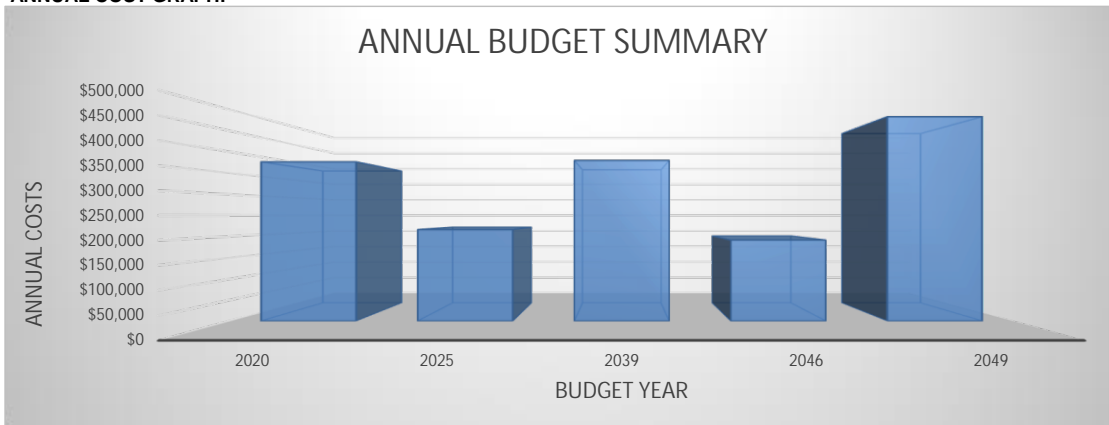
The park is in exceptional condition given it's age.

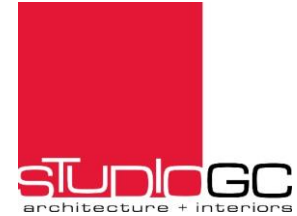
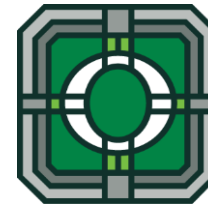
- Much of the play equipment has aged well and has only minimal deterioration requiring spot repair.
- The sand play area is nicely separated from the surrounding area but is hard packed.
- Tennis courts has some cracks but not effecting play.

Score **2.87**

Score Average **2.84**

ANNUAL COST GRAPH:





COST BY BUDGET YEAR:

DOOGAN PARK

Budget Year	Component	Detail	Values	
			Sum of 2019 Replacement Cost	Sum of Escalated Budget
2020	PARK AMENITIES	Benches	\$2,000.00	\$2,130.00
		Trash/Recycling	\$800.00	\$852.00
		Drinking Fountain	\$6,500.00	\$6,922.50
	Play Component	Elevated Structures (2)	\$75,000.00	\$79,875.00
		Ground Equipment	\$6,000.00	\$6,390.00
	RECREATION COMPONENTS	Basketball Courts	\$67,500.00	\$71,887.50
		Tennis Court	\$196,000.00	\$208,740.00
2020 Total			\$353,800.00	\$376,797.00
2025	PARK AMENITIES	Pavilion	\$100,000.00	\$145,914.23
	Play Component	Fiber Play Surface	\$33,500.00	\$48,881.27
	RECREATION COMPONENTS	Football Posts	\$15,000.00	\$21,887.13
2025 Total			\$148,500.00	\$216,682.63
2039	SITE COMPONENTS	Concrete Walks	\$71,525.00	\$252,028.71
		Concrete Patio	\$21,600.00	\$76,110.73
	Play Component	Edge Restraint	\$14,782.00	\$52,086.52
2039 Total			\$107,907.00	\$380,225.97
2046	RECREATION COMPONENTS	Baseball Field	\$35,000.00	\$191,649.40
2046 Total			\$35,000.00	\$191,649.40

Description/Life Expectancy		Task	Installed Date	Service Life	Anticipated Replacement Date	Assessments			Evaluated Condition			Estimated Cost Data - 2019						Comments		
Component	Detail		(year)	(years)	(year)	Security (1-5) (0 is lowest)	General (1-5) (0 is lowest)	Accessibility (1-5) (0 is lowest)	Evaluation Date (year)	Life Expectancy Modifier %	Life Expectancy Beyond Evaluation (years remaining) (0 is lowest)	Budget Year	Qty	Units	Prorate	Unit Cost	2019 Replacement Cost (As of Evaluation date)	Escalated Budget		
SITE COMPONENTS						3														
Site Components	Concrete Walks		1999	40	2039		2	4	2019	0%	0	2039	14,305	sf		\$5.00	\$71,525	\$252,029		
Site Components	Concrete Patio		1999	40	2039		2	3	2019	0%	0	2039	1,200	sf		\$18.00	\$21,600	\$76,111		
Site Components	Landscaping		1999	50	2049		2		2019	0%	0	2049	731,000	sf		\$0.10	\$73,100	\$483,510		
PLAY COMPONENTS																				
Play Component	Elevated Structures (2)		1999	15	2014		3	3	2019	40%	6	2020	3	each		\$25,000.00	\$75,000	\$79,875	See Accessibility Chart	
Play Component	Ground Equipment		1999	15	2014		3	3	2019	40%	6	2020	5	each		\$1,200.00	\$6,000	\$6,390	See Accessibility Chart	
Play Component	Fiber Play Surface		2017	8	2025		3	3	2019	0%	0	2025	6,700	sf		\$5.00	\$33,500	\$48,881		
Play Component	Edge Restraint		1999	40	2039		4		2019	0%	0	2039	389	lf		\$38.00	\$14,782	\$52,087	Plastic Edging	
PARK AMENITIES																				
Park Amenities	Pavilion		1999	25	2024		3	3	2019	5%	1	2025	1,000	sf		\$100.00	\$100,000	\$145,914		
Park Amenities	Benches		1999	10	2009		3	3	2019	110%	11	2020	2	each		\$1,000.00	\$2,000	\$2,130		
Park Amenities	Drinking Fountain		1999	15	2014		3	3	2019	40%	6	2020	1	each		\$6,500.00	\$6,500	\$6,923		
Park Amenities	Trash/Recycling		1999	10	2009		3		2019	110%	11	2020	2	each		\$400.00	\$800	\$852		
RECREATION COMPONENTS																				
Recreation Components	Basketball Courts		1996	20	2016		3	2	2019	20%	4	2020	0.5	each		\$135,000.00	\$67,500	\$71,888		
Recreation Components	Baseball Field		1996	50	2046		2	3	2019	0%	0	2046	1.0	each		\$35,000.00	\$35,000	\$191,649		
Recreation Components	Tennis Court		1996	20	2016		3	1	2019	20%	4	2020	2	each		\$98,000.00	\$196,000	\$208,740		
Recreation Components	Football Posts		1996	20	2016		4	1	2019	45%	9	2025	1	each		\$15,000.00	\$15,000	\$21,887		
						3.00	2.87	2.67									\$718,307	\$1,648,865		

NOTES

Evaluation of building conditions focused on the elements likely to be included in the budget for items expected to require replacement or renovation within the next 10 to 15 years. Equipment, materials, or assemblies that are nominal in cost are not included. This is therefore not a comprehensive list but does identify major expenses that are likely to be incurred in the foreseeable future.

Conditions change with time, and this evaluation, along with the funds allocated to cover the associated expenses should be reviewed and revised periodically as the department's needs evolve. Unanticipated expenses can develop for a number of reasons including accelerated use or changes in use patterns, accident, or deferred general maintenance. Such reviews should include updating baseline costs and dates for the components or assemblies identified in this study.

Costs are calculated at 2019 levels and escalated at the following presumed annual rate of inflation:

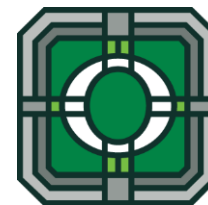
6.50% per annum

This report is broken up into different categories. The first three are organized by category with like expenses grouped together. The worksheets also covers Mechanical expenses, Electrical expenses, and Plumbing expenses. The last worksheet is organized by the computed year of expense (Budget Year).

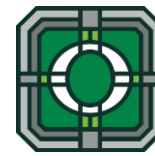
Repair/replacement work items do not include A/E Design Fees in the cost.

Total Combined Facilities

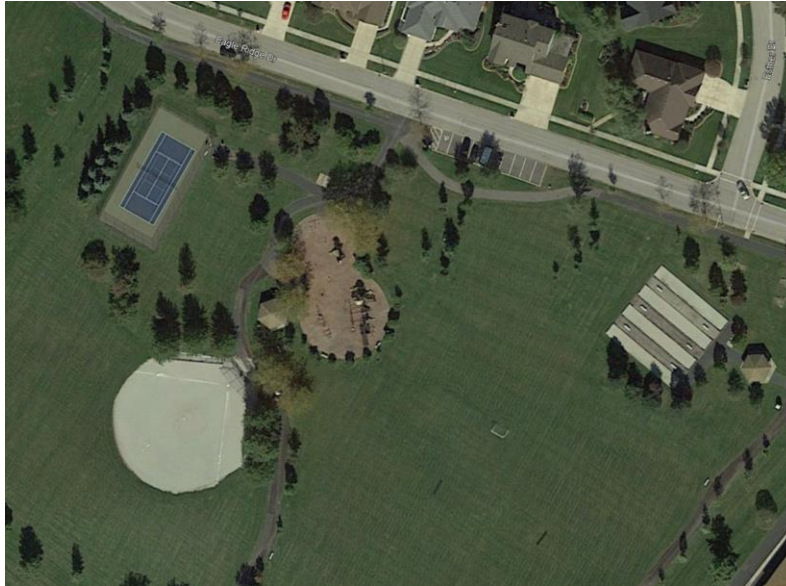
2020	\$376,797
2025	\$216,683
2039	\$380,226
2046	\$191,649
2049	\$483,510
Total:	\$1,648,865



NAME: EAGLE RIDGE I PARK
ADDRESS: 10755 Eagle Ridge Dr, Orland Park, IL 60462
PARK TYPE: Community
EVALUATION YEAR: 2019



PARK MAP:



PARK DATA:

Year Renovated:	2013
Park Age:	6
Total Acreage:	10
Total Parking Spaces:	10

Amenities:

Playground Equip:	Landscape Struct.
Baseball/ Softball Field	1
Bean Bag Boards	
Bocce Ball	4
Drinking Fountain	
Horseshoes	
Pavilion	2
Pickleball	
Picnic Grills	
Playground	
Soccer Field	1
Tennis Court	1

SECURITY COMMENTS:

Score **3.00**

Park security is as to be expected for this size facility. See a few specific areas of note and one concern:
 - Great visibility from public ways
 - Security lighting should be considered if law enforcement has concerns.

ACCESSIBILITY COMMENTS

Score **2.30**

The park is generally accessible. In general all park amenities are accessible via an asphalt path. The deterioration of the path is affecting the compliance. Other aspects appear to meet the 2010 Accessibility Code. However there is no accessible route to the bocce ball area and the fiber play surfacing.

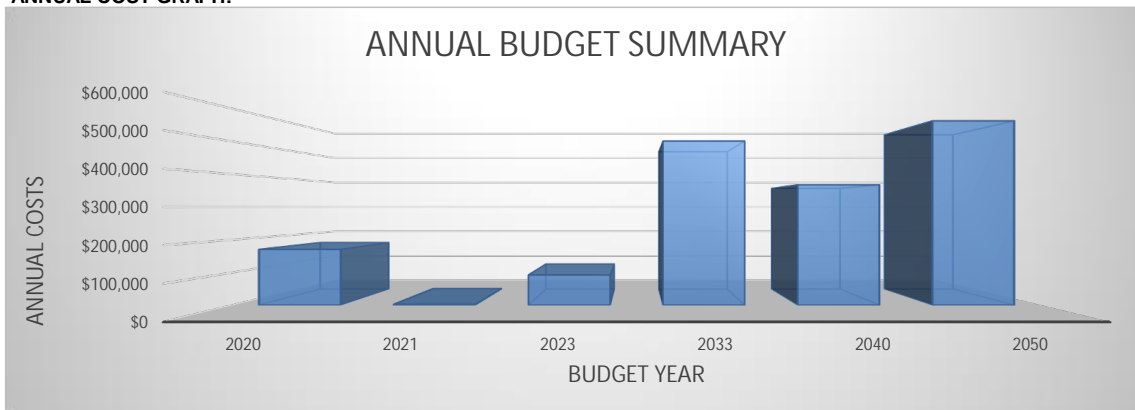
GENERAL CONDITION COMMENTS

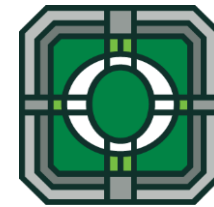
Score **2.36**

The play equipment appears to be in good condition. The rest of the park does not appear to have been renovated when the play equipment was updated.

Score Average 2.55

ANNUAL COST GRAPH:





COST BY BUDGET YEAR:

EAGLE RIDGE I PARK

Budget Year	Component	Detail	Values	
			Sum of 2019 Replacement Cost	Sum of Escalated Budget
2020	SITE COMPONENTS	Concrete Patios	\$32,184.00	\$34,275.96
	PARK AMENITIES	Benches	\$17,000.00	\$18,105.00
		Pavilion	\$104,500.00	\$111,292.50
		Trash/Recycling	\$1,200.00	\$1,278.00
	RECREATION COMPONENTS	Soccer Goals (practice)	\$5,000.00	\$5,325.00
2020 Total			\$159,884.00	\$170,276.46
2021	PARK AMENITIES	Drinking Fountains	\$2,500.00	\$2,835.56
2021 Total			\$2,500.00	\$2,835.56
2023	Play Component	Mulch		\$51,542.27
	RECREATION COMPONENTS	Fencing	\$31,440.00	\$40,446.50
2023 Total			\$71,505.00	\$91,988.78
2033	Play Component	Elevated Structures (2)	\$62,500.00	\$150,929.64
		Ground Equipment	\$10,000.00	\$24,148.74
	RECREATION COMPONENTS	Tennis Court	\$135,000.00	\$326,008.01
2033 Total			\$207,500.00	\$501,086.39
2040	SITE COMPONENTS	Concrete Walks	\$83,800.00	\$314,474.75
	Play Component	Edge Restraint	\$14,136.00	\$53,047.91
2040 Total			\$97,936.00	\$367,522.66
2050	SITE COMPONENTS	Landscaping	\$44,888.58	\$316,208.62
	RECREATION COMPONENTS	Baseball Field	\$35,000.00	\$246,550.50
2050 Total			\$79,888.58	\$562,759.12
Grand Total			\$619,213.58	\$1,696,468.98

Description/Life Expectancy		Task	Installed Date	Service Life	Anticipated Replacement Date	Assessments			Evaluated Condition			Estimated Cost Data - 2019					Comments		
Component	Detail		(year)	(years)	(year)	Security (1-5)	General (1-5)	Accessibility (1-5)	Evaluation Date		Life Expectancy Beyond Evaluation (years remaining)	Budget Year	Qty	Units	Prorate	Unit Cost		2019 Replacement Cost	Escalated Budget
						(0 is lowest)	(0 is lowest)	(0 is lowest)	(year)	%	(0 is lowest)							(As of Evaluation date)	
SITE COMPONENTS						3													
Site Components	Concrete Walks		2000	40	2040		2		2019	0%	0	2040	16,760	sf		\$5.00	\$83,800	\$314,475	
Site Components	Concrete Patios		2000	20	2020				2019	0%	0	2020	1,788	sf		\$18.00	\$32,184	\$34,276	
Site Components	Landscaping		2000	50	2050		2		2019	0%	0	2050	498,762	sf		\$0.09	\$44,889	\$316,209	
PLAY COMPONENTS						3													
Play Component	Elevated Structures (2)		2013	15	2028		3	3	2019	30%	5	2033	3	each		\$25,000.00	\$62,500	\$150,930	See Accessibility Chart
Play Component	Ground Equipment		2013	15	2028		3	3	2019	30%	5	2033	4	each		\$2,500.00	\$10,000	\$24,149	See Accessibility Chart
Play Component	Mulch		2013	10	2023		3	1	2019	0%	0	2023	8,013	sf		\$5.00	\$40,065	\$51,542	
Play Component	Edge Restraint		2000	40	2040		2		2019	0%	0	2040	372	lf		\$38.00	\$14,136	\$53,048	Plastic Edging
PARK AMENITIES						3													
Park Amenities	Benches		2000	10	2010		2	2	2019	100%	10	2020	17	each		\$1,000.00	\$17,000	\$18,105	
Park Amenities	Trash/Recycling		2000	10	2010		3	3	2019	100%	10	2020	3	each		\$400.00	\$1,200	\$1,278	
Park Amenities	Drinking Fountains		2000	15	2015				2019	35%	5	2021	1	each		\$2,500.00	\$2,500	\$2,836	
Park Amenities	Pavilion		2000	20	2020		3	3	2019	0%	0	2020	1,045	sf		\$100.00	\$104,500	\$111,293	
RECREATION COMPONENTS						3													
Recreation Components	Baseball Field		2000	50	2050		3	3	2019	0%	0	2050	1	each		\$35,000.00	\$35,000	\$246,550	
Recreation Components	Tennis Court		2013	20	2033		2	3	2019	0%	0	2033	1	each		\$135,000.00	\$135,000	\$326,008	
Recreation Components	Soccer Goals (practice)		2013	5	2018		3	1	2019	30%	2	2020	1	each		\$5,000.00	\$5,000	\$5,325	
Recreation Components	Fencing		2013	10	2023		1	1	2019	0%		2023	524	lf		\$60.00	\$31,440	\$40,447	
Recreation Components	Bocce Ball Court		2013		2013		1	2	2019	0%		2013	4	each		\$0.00	\$0	\$0	
						3.00	2.36	2.30						\$582,774	\$1,650,697				

NOTES

Evaluation of building conditions focused on the elements likely to be included in the budget for items expected to require replacement or renovation within the next 10 to 15 years. Equipment, materials, or assemblies that are nominal in cost are not included. This is therefore not a comprehensive list but does identify major expenses that are likely to be incurred in the foreseeable future.

Conditions change with time, and this evaluation, along with the funds allocated to cover the associated expenses should be reviewed and revised periodically as the department's needs evolve. Unanticipated expenses can develop for a number of reasons including accelerated use or changes in use patterns, accident, or deferred general maintenance. Such reviews should include updating baseline costs and dates for the components or assemblies identified in this study.

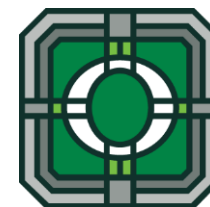
Costs are calculated at 2019 levels and escalated at the following presumed annual rate of inflation:

6.50% per annum

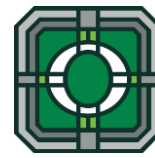
This report is broken up into different categories. The first three are organized by category with like expenses grouped together. The worksheets also covers Mechanical expenses, Electrical expenses, and Plumbing expenses. The last worksheet is organized by the computed year of expense (Budget Year).

Repair/replacement work items do not include A/E Design Fees in the cost.

Total Combined Facilities	
2020	\$170,276
2021	\$2,836
2023	\$91,989
2033	\$501,086
2040	\$367,523
2050	\$562,759
Total:	\$1,696,469



NAME: EAGLE RIDGE II PARK
ADDRESS: 11190 Bernard Dr, Orland Park, IL 60462
PARK TYPE: Community
EVALUATION YEAR: 2019



PARK MAPS:



PARK DATA:

Year Renovated:	1999
Park Age:	20
Total Acreage:	7
Total Parking Spaces:	42

Amenities:

Playground Equip:	Gametime
Baseball/Softball Field	1
Bike/ Walking Path	
Bocce Ball	2
Fishing	
Lacrosse Field	
Pavilion	
Picnic Grills	

SECURITY COMMENTS:

Score 3.00

- Park security is as to be expected for this size facility. See a few specific areas of note and one concern:
- Great visibility from public ways
 - Security lighting should be considered if law enforcement has concerns.

ACCESSIBILITY COMMENTS

Score 3.30

- Generally most of the park appears to meet the 2010 Accessibility Code.
- In general all park amenities are accessible via an asphalt path. The deterioration of the path is effecting the compliance.
 - However there is no accessible route to the bocce ball area and the fiber play surfacing.

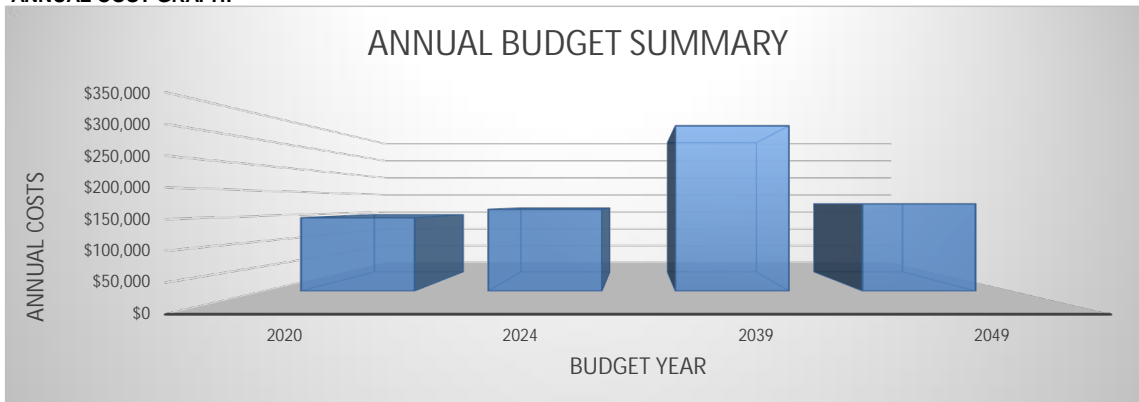
GENERAL CONDITION COMMENTS

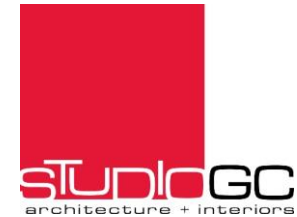
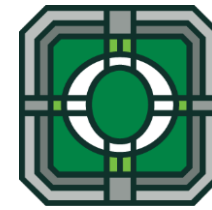
Score 2.31

- The play equipment appears to be in good condition given the age.
- There is some deterioration on the play equipment that will eventually necessitate replacement of the equipment.
 - The pavilion seems to be in good condition.
 - The asphalt walking path paving is in poor condition
 - Fibar is washing out indicating drainage or grading issues.

Score Average 2.87

ANNUAL COST GRAPH:





COST BY BUDGET YEAR:

EAGLE RIDGE II PARK

Budget Year	Component	Detail	Values	
			Sum of 2019 Replacement Cost	Sum of Escalated Budget
2020	SITE COMPONENTS	Concrete Patios	\$34,488.00	\$36,729.72
		Asphalt - Sealcoat	\$16,848.00	\$17,943.12
	PARK AMENITIES	Benches	\$15,000.00	\$15,975.00
		Trash/Recycling	\$1,600.00	\$1,704.00
	Play Component	Elevated Structures (2)	\$25,002.00	\$26,627.13
		Ground Equipment	\$2,502.00	\$2,664.63
		Mulch	\$31,540.00	\$33,590.10
	RECREATION COMPONENTS	Play Sand Area	\$10,246.00	\$10,911.99
		Bocce Ball Court	\$0.00	\$0.00
2020 Total			\$137,226.00	\$146,145.69
2024	PARK AMENITIES	Pavilion	\$83,900.00	\$114,950.27
	RECREATION COMPONENTS	Baseball Field	\$35,000.00	\$47,953.03
2024 Total			\$118,900.00	\$162,903.30
2039	SITE COMPONENTS	Concrete Walks	\$79,300.00	\$279,425.05
	Play Component	Edge Restraint	\$14,136.00	\$49,810.25
2039 Total			\$93,436.00	\$329,235.30
2049	SITE COMPONENTS	Landscaping	\$26,266.68	\$173,737.44
2049 Total			\$26,266.68	\$173,737.44
Grand Total			\$375,828.68	\$812,021.73

Description/Life Expectancy						Assessments			Evaluated Condition			Estimated Cost Data - 2019								
Component	Detail	Task	Installed Date	Service Life	Anticipated Replacement Date	Security (1-5)	General (1-5)	Accessibility (1-5)	Evaluation Date	Life Expectancy Modifier	Life Expectancy Beyond Evaluation (years remaining)	Budget Year	Qty	Units	Prorate	Unit Cost	2019 Replacement Cost	Escalated Budget	Comments	
			(year)	(years)	(year)	(0 is lowest)	(0 is lowest)	(0 is lowest)	(year)	%	(0 is lowest)						(As of Evaluation date)			
SITE COMPONENTS						3														
Site Components	Asphalt - Sealcoat		2017	2	2019				2019	25%	1	2020	16,848	sf		\$1.00	\$16,848	\$17,943		
Site Components	Concrete Walks		1999	40	2039		2	3	2019	0%	0	2039	15,860	sf		\$5.00	\$79,300	\$279,425		
Site Components	Concrete Patios		1999	20	2019		3		2019	5%	1	2020	1,916	sf		\$18.00	\$34,488	\$36,730		
Site Components	Landscaping		1999	50	2049		2		2019	0%	0	2049	525,334	sf		\$0.05	\$26,267	\$173,737		
Site Components	Parking Spaces/Lot (10+1HC)		2017	5	2022				2019	0%	0	2022	42	each		\$100.00	\$4,200	\$5,073	2 Handicapped	
PLAY COMPONENTS																				
Play Component	Elevated Structures (2)		1999	15	2014		2	4	2019	40%	6	2020	2	each		\$25,000.00	\$25,002	\$26,627	See Accessibility Chart	
Play Component	Ground Equipment		1999	15	2014		2	4	2019	40%	6	2020	2	each		\$2,500.00	\$2,502	\$2,665	See Accessibility Chart	
Play Component	Mulch		2010	10	2020		1	3	2019	0%	0	2020	6,308	sf		\$5.00	\$31,540	\$33,590		
Play Component	Play Sand Area		2010	10	2020		1	1	2019	0%	0	2020	218	sf		\$47.00	\$10,246	\$10,912		
Play Component	Edge Restraint		1999	40	2039		4		2019	0%	0	2039	372	lf		\$38.00	\$14,136	\$49,810	Plastic Edging	
PARK AMENITIES																				
Park Amenities	Benches		1999	10	2009		3	3	2019	110%	11	2020	15	each		\$1,000.00	\$15,000	\$15,975		
Park Amenities	Trash/Recycling		1999	10	2009		3	3	2019	110%	11	2020	4	each		\$400.00	\$1,600	\$1,704		
Park Amenities	Pavilion		1999	25	2024		4	4	2019	0%	0	2024	839	sf		\$100.00	\$83,900	\$114,950		
RECREATION COMPONENTS																				
Recreation Components	Bocce Ball Court		1999				2	2	2,019	0%	0	2020	2			\$0.00	\$0	\$0		
Recreation Components	Baseball Field		1999	25	2024		2	4	2019	0%	0	2024	1	each		\$35,000.00	\$35,000	\$47,953		
						3.00	2.38	3.10							\$380,029	\$817,095				

NOTES

Evaluation of building conditions focused on the elements likely to be included in the budget for items expected to require replacement or renovation within the next 10 to 15 years. Equipment, materials, or assemblies that are nominal in cost are not included. This is therefore not a comprehensive list but does identify major expenses that are likely to be incurred in the foreseeable future.

Conditions change with time, and this evaluation, along with the funds allocated to cover the associated expenses should be reviewed and revised periodically as the department's needs evolve. Unanticipated expenses can develop for a number of reasons including accelerated use or changes in use patterns, accident, or deferred general maintenance. Such reviews should include updating baseline costs and dates for the components or assemblies identified in this study.

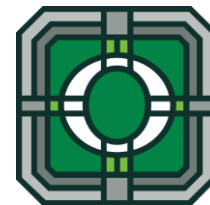
Costs are calculated at 2019 levels and escalated at the following presumed annual rate of inflation:

6.50% per annum

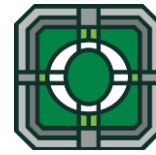
This report is broken up into different categories. The first three are organized by category with like expenses grouped together. The worksheets also covers Mechanical expenses, Electrical expenses, and Plumbing expenses. The last worksheet is organized by the computed year of expense (Budget Year).

Repair/replacement work items do not include A/E Design Fees in the cost.

Total Combined Facilities	
2020	\$146,146
2024	\$162,903
2039	\$329,235
2049	\$173,737
Total:	\$812,022



NAME: EAGLE RIDGE III PARK
ADDRESS: 10630 Rachel Lane, Orland Park, IL 60462
PARK TYPE: Neighborhood
EVALUATION YEAR: 2019



PARK MAP:



PARK DATA:

Year Renovated:	2001
Park Age:	18
Total Acreage:	3
Total Parking Spaces:	0

Amenities:

Playground Equip	Miracle
Bike/ Walking	
Bocce Ball	2
Climbing Wall	
Drinking Fountain	
Handicap Swing	
Horseshoes	
Pavilion	
Picnic Grills	

SECURITY COMMENTS:

- No security concerns.
- Park is well visible from the roadway and there is sufficient distance to allow for roadway safety.
- General site lighting is recommended due to park size if law enforcement has concerns.

Score 4.00

ACCESSIBILITY COMMENTS

- There are no accessibility concerns.
- A full study should be completed as this park predates the 2010 Accessibility Code update.
- This scores higher because there appears to be an accessible route into the play area.

Score 3.13

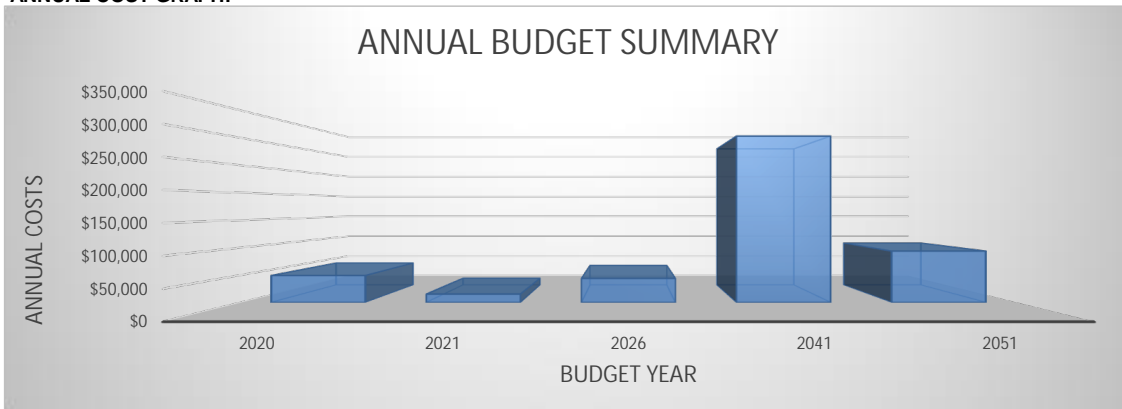
GENERAL CONDITION COMMENTS

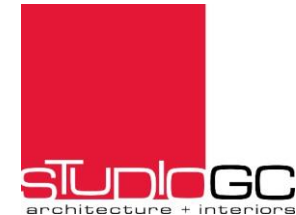
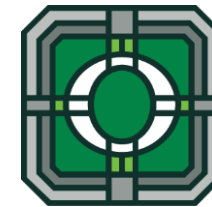
- The park is in good condition.
- There is cosmetic damage to the playground equipment.
- Mulch appears to need to be refreshed.
- Asphalt paths have reached near the end of their useful life.
- Further evaluation of the use of bocce ball courts is necessary. These are not accessible and in disrepair.

Score 2.83

Score Average 3.32

ANNUAL COST GRAPH:





COST BY BUDGET YEAR:

EAGLE RIDGE III PARK

Budget Year	Component	Detail	Values	
			Sum of 2019 Replacement Cost	Sum of Escalated Budget
2020	PARK AMENITIES	Benches	\$5,000.00	\$5,325.00
		Trash/Recycling	\$400.00	\$426.00
	Play Component	Mulch	\$40,725.00	\$43,372.13
2020 Total			\$46,125.00	\$49,123.13
2021	SITE COMPONENTS	Concrete Patios	\$13,464.00	\$15,271.21
2021 Total			\$13,464.00	\$15,271.21
2026	PARK AMENITIES	Pavilion	\$28,200.00	\$43,822.42
2026 Total			\$28,200.00	\$43,822.42
2041	SITE COMPONENTS	Concrete Walks	\$57,650.00	\$230,404.35
	Play Component	Edge Restraint	\$18,202.00	\$72,746.23
2041 Total			\$75,852.00	\$303,150.58
2051	SITE COMPONENTS	Landscaping	\$12,475.58	\$93,594.07
2051 Total			\$12,475.58	\$93,594.07
Grand Total			\$176,116.58	\$504,961.40

Description/Life Expectancy						Assessments			Evaluated Condition			Estimated Cost Data - 2019						Comments	
Component	Detail	Task	Installed Date	Service Life	Anticipated Replacement Date	Security (1-5)	General (1-5)	Accessibility (1-5)	Evaluation Date	Life Expectancy Modifier	Life Expectancy Beyond Evaluation (years remaining)	Budget Year	Qty	Units	Prorate	Unit Cost	2019 Replacement Cost		Escalated Budget
			(year)	(years)	(year)	(0 is lowest)	(0 is lowest)	(0 is lowest)	(year)	%	(0 is lowest)						(As of Evaluation date)		
SITE COMPONENTS						4													
Site Components	Concrete Walks		2001	40	2041		3	4	2019	0%	0	2041	11,530	sf		\$5.00	\$57,650	\$230,404	
Site Components	Concrete Patios		2001	20	2021		3	4	2019	0%	0	2021	748	sf		\$18.00	\$13,464	\$15,271	
Site Components	Landscaping		2001	50	2051		3		2019	0%	0	2051	155,945	sf		\$0.08	\$12,476	\$93,594	
PLAY COMPONENTS																			
Play Component	Elevated Structures (2)		2001	15	2016		3	3	2019	30%	5	2021	2	each		\$25,000.00	\$50,000	\$54,953	
Play Component	Ground Equipment		2001	15	2016		3	3	2019	30%	5	2021	3	each		\$2,500.00	\$7,500	\$8,243	
Play Component	Mulch		2010	10	2020		2	3	2019	0%	0	2020	8,145	sf		\$5.00	\$40,725	\$43,372	
Play Component	Edge Restraint		2001	40	2041		3		2019	0%	0	2041	479	lf		\$38.00	\$18,202	\$72,746	
PARK AMENITIES																			
Park Amenities	Benches		2001	10	2011		3	3	2019	90%	9	2020	5	each		\$1,000.00	\$5,000	\$5,325	
Park Amenities	Trash/Recycling		2001	10	2011		3	3	2019	90%	9	2020	1	each		\$400.00	\$400	\$426	
Park Amenities	Drinking Fountains		2001	15	2016		3		2019	30%	5	2021	1	each		\$2,500.00	\$2,500	\$2,748	
Park Amenities	Pavilion		2001	25	2026		3		2019	0%	0	2026	282	sf		\$100.00	\$28,200	\$43,822	
RECREATION COMPONENTS																			
Recreation Components	Bocce Ball Court		2001				2	2					2	each		\$0.00	\$0	\$0	
						4.00	2.83	3.13							\$236,117	\$570,905			

NOTES

Evaluation of building conditions focused on the elements likely to be included in the budget for items expected to require replacement or renovation within the next 10 to 15 years. Equipment, materials, or assemblies that are nominal in cost are not included. This is therefore not a comprehensive list but does identify major expenses that are likely to be incurred in the foreseeable future.

Conditions change with time, and this evaluation, along with the funds allocated to cover the associated expenses should be reviewed and revised periodically as the Department's needs evolve. Unanticipated expenses can develop for a number of reasons including accelerated use or changes in use patterns, accident, or deferred general maintenance. Such reviews should include updating baseline costs and dates for the components or assemblies identified in this study.

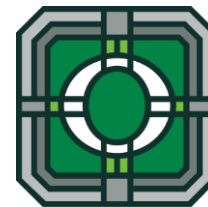
Costs are calculated at 2019 levels and escalated at the following presumed annual rate of inflation:

6.50% per annum

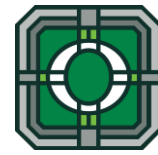
This report is broken up into different categories. The first three are organized by category with like expenses grouped together. The worksheets also covers Mechanical expenses, Electrical expenses, and Plumbing expenses. The last worksheet is organized by the computed year of expense (Budget Year).

Repair/replacement work items do not include A/E Design Fees in the cost.

Total Combined Facilities	
2020	\$49,123
2021	\$15,271
2026	\$43,822
2041	\$303,151
2051	\$93,594
Total:	\$504,961



NAME: EMERALD ESTATES PARK
ADDRESS: 10550 Emerald Ave, Orland Park, IL 60462
PARK TYPE: Neighborhood
EVALUATION YEAR: 2019



PARK MAP:



PARK DATA:

Year Renovated:	2002
Park Age:	17
Total Acreage:	1.5
Total Parking Spaces:	0

Amenities:

Playground Equip:	Kompan
Basketball Court	
Bike/ Walking Path	
Drinking Fountain	
Pickleball	
Tennis court	1

SECURITY COMMENTS:

- No security concerns,
- Security level lighting should be considered if law enforcement has concerns
- Park is visible from roadway
- Perimeter fencing at roadways should be considered

Score **3.00**

ACCESSIBILITY COMMENTS

- The playground was constructed prior to the 2010 Accessibility Update. There are a few items of note:
- There play structure does not appear compliant and there are not enough ground play elements to meet ADA compliance.
- The walkway as compliant but access to the play surface does not appear to be so.

Score **2.17**

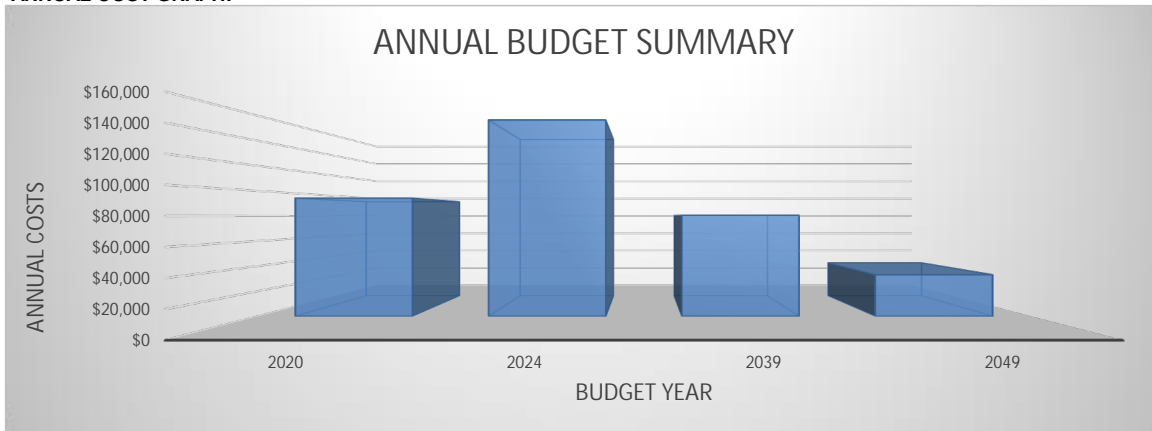
GENERAL CONDITION COMMENTS

- Given the age the park is in very good condition.
- Playground system should be evaluated for replacement elements.
- Playground equipment is in better shape than expected.
- All other elements are in good shape and aligned with life cycle expectations.
- Site is missing typical Village park sign.

Score **3.08**

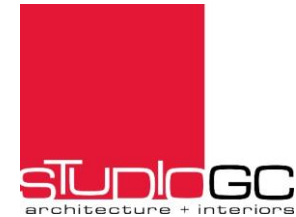
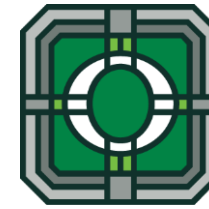
Score Average 2.75

ANNUAL COST GRAPH:



COST BY BUDGET YEAR:

EMERALD ESTATES PARK



Budget Year	Component	Detail	Values	
			Sum of 2019 Replacement Cost	Sum of Escalated Budget
2020	SITE COMPONENTS	Concrete Patios	\$18,000.00	\$19,170.00
		PARK AMENITIES	Benches	\$1,000.00
		Picnic Grills	\$1,500.00	\$1,597.50
	Play Component	Elevated Structures (2)	\$50,000.00	\$53,250.00
		Ground Equipment	\$1,200.00	\$1,278.00
		Mulch	\$7,355.00	\$7,833.08
		Sand Play Area	\$9,400.00	\$10,011.00
2020 Total			\$88,455.00	\$94,204.58
2024	SITE COMPONENTS	Parking Spaces (20)	\$1,000.00	\$1,370.09
		Asphalt	\$70,000.00	\$95,906.07
	PARK AMENITIES	Pavilion	\$43,200.00	\$59,187.74
2024 Total			\$114,200.00	\$156,463.90
2039	SITE COMPONENTS	Concrete Walks	\$17,175.00	\$60,518.60
	Play Component	Edge Restraint	\$5,662.00	\$19,950.88
2039 Total			\$22,837.00	\$80,469.48
2049	SITE COMPONENTS	Landscaping	\$5,000.00	\$33,071.83
2049 Total			\$5,000.00	\$33,071.83
Grand Total			\$230,492.00	\$364,209.79

Description/Life Expectancy		Installed Date	Service Life	Anticipated Replacement Date	Assessments			Evaluated Condition			Estimated Cost Data - 2019						Comments		
Component	Detail	Task	Installed Date	Service Life	Anticipated Replacement Date	Security (1-5)	General (1-5)	Accessibility (1-5)	Evaluation Date	Life Expectancy Modifier	Life Expectancy Beyond Evaluation (years remaining)	Budget Year	Qty	Units	Prorate	Unit Cost		Estimate of Replacement Cost - 2019	Escalated Budget
			(year)	(years)	(year)	(0 is lowest)	(0 is lowest)	(0 is lowest)	(year)	%	(0 is lowest)							(As of Evaluation date)	
SITE COMPONENTS						3													
Site Components	Concrete Walks		2002	40	2042		3	3	2019	0%	0	2042	6,750	sf		\$5.00	\$33,750	\$143,653	
Site Components	Landscaping		2002	50	2052		3		2019	0%	0	2052	108,029	sf		\$0.20	\$21,606	\$172,626	
PLAY COMPONENTS																			
Play Component	Elevated Structures (2)		2002	15	2017		3	1	2019	20%	3	2020	2	each		\$25,000.00	\$50,000	\$53,250	See Accessibility Chart
Play Component	Ground Equipment		2002	15	2017		3	1	2019	20%	3	2020	2	each		\$2,500.00	\$5,000	\$5,325	See Accessibility Chart
Play Component	Mulch		2010	10	2020		3	2	2019	0%	0	2020	4,156	sf		\$5.00	\$20,780	\$22,131	
Play Component	Edge Restraint		2002	40	2042		5		2019	0%	0	2042	261	lf		\$38.00	\$9,918	\$42,215	Plastic Edging
PARK AMENITIES																			
Park Amenities	Benches		2002	10	2012		3	3	2019	80%	8	2020	1	each		\$1,000.00	\$1,000	\$1,065	
Park Amenities	Trash/Recycling		2002	10	2012		3		2019	80%	8	2020	2	each		\$400.00	\$800	\$852	
Park Amenities	Bike Racks/Systems		2002	10	2012		3		2019	80%	8	2020	1	each		\$400.00	\$400	\$426	
Park Amenities	Drinking Fountains		2002	15	2017		2	3	2019	20%	3	2020	1	each			\$0	\$0	
RECREATION COMPONENTS																			
Recreation Components	Basketball Courts		2002	20	2022		3		2019	0%	0	2022	1	each		\$115,000.00	\$115,000	\$138,914	
Recreation Components	Tennis Court		2002	20	2022		3		2019	0%	0	2022	1	each		\$135,000.00	\$135,000	\$163,073	
						3.00	3.08	2.17							\$393,254	\$743,530			

NOTES

Evaluation of building conditions focused on the elements likely to be included in the budget for items expected to require replacement or renovation within the next 10 to 15 years. Equipment, materials, or assemblies that are nominal in cost are not included. This is therefore not a comprehensive list but does identify major expenses that are likely to be incurred in the foreseeable future.

Conditions change with time, and this evaluation, along with the funds allocated to cover the associated expenses should be reviewed and revised periodically as the Department's needs evolve. Unanticipated expenses can develop for a number of reasons including accelerated use or changes in use patterns, accident, or deferred general maintenance. Such reviews should include updating baseline costs and dates for the components or assemblies identified in this study.

Costs are calculated at 2019 levels and escalated at the following presumed annual rate of inflation:

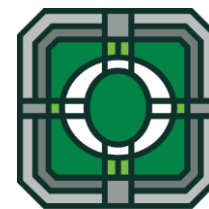
6.50% per annum

This report is broken up into different categories. The first three are organized by category with like expenses grouped together. The worksheets also covers Mechanical expenses, Electrical expenses, and Plumbing expenses. The last worksheet is organized by the computed year of expense (Budget Year).

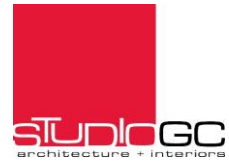
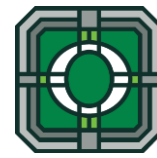
Repair/replacement work items do not include A/E Design Fees in the cost.

Total Combined Facilities

2020	\$94,205
2024	\$156,464
2039	\$80,469
2049	\$33,072
Total:	\$364,210



NAME: EQUESTRIAN PARK
ADDRESS: 15621 Shire Dr, Orland Park, IL 60462
PARK TYPE: Neighborhood
EVALUATION YEAR: 2019



PARK MAP:



PARK DATA:

Year Renovated:	1998
Park Age:	21
Total Acreage:	2.1
Total Parking Spaces:	0

Amenities:

Playground Equip:	Landscape Structures
Bike/ Walking Path	
Pavilion	
Picnic Grills	

NOTE: Map also shows Somer Glen Park to the East.

SECURITY COMMENTS:

Score **4.00**

- Park security is as to be expected for this size facility. See a few specific areas of note and one concern:
- Great visibility from public ways
 - Security lighting should be considered if law enforcement has concerns.

ACCESSIBILITY COMMENTS

Score **2.00**

- The park seems to only have a few areas of concern:
- The playground equipment needs a full evaluation. It does not appear compliant and does not have the proper size transfer points.
 - The play surface has an appropriate concrete ramp. More locations are recommended.

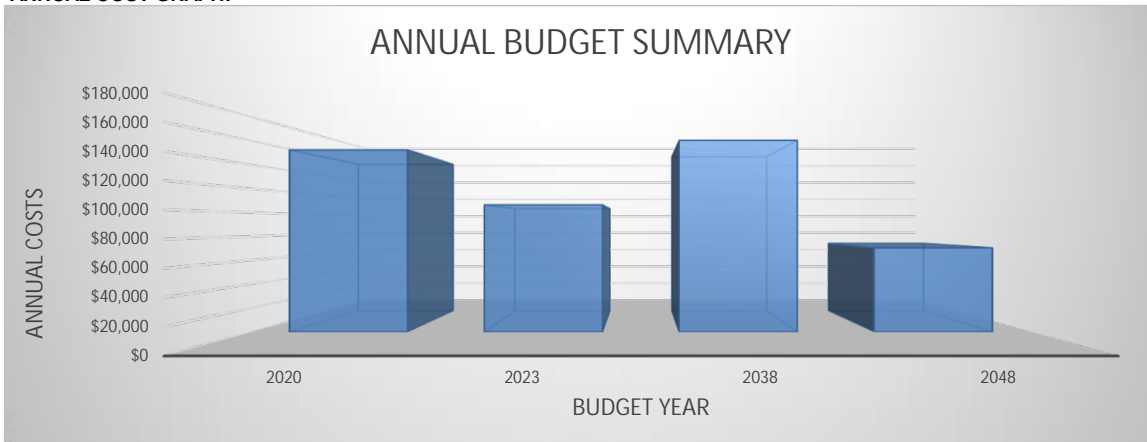
GENERAL CONDITION COMMENTS

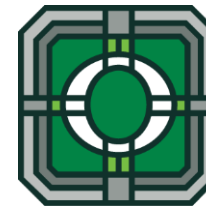
Score **2.73**

- Park is in generally good condition. A few items of note:
- Retaining walls incorporated into the play areas are a safety concern and are coated in mildew.
 - Ground equipment is faded
 - The play equipment has only cosmetic issues.
 - Recommended removal of sand play areas, they are not considered accessible and has a regular occurrence ground bees.

Score Average **2.91**

ANNUAL COST GRAPH:





COST BY BUDGET YEAR:

EQUESTRIAN PARK

Budget Year	Component	Detail	Values	
			Sum of 2019 Replacement Cost	Sum of Escalated Budget
2020	SITE COMPONENTS	Concrete Patios	\$60,066.00	\$63,970.29
		PARK AMENITIES	Benches	\$1,000.00
		Trash/Recycling	\$3,600.00	\$3,834.00
	Play Component	Mulch	\$59,475.00	\$63,340.88
		Sand Play Area	\$18,988.00	\$20,222.22
2020 Total			\$143,129.00	\$152,432.39
2023	PARK AMENITIES	Pavilion	\$82,700.00	\$106,390.77
2023 Total			\$82,700.00	\$106,390.77
2038	SITE COMPONENTS	Concrete Walks	\$15,825.00	\$52,358.39
	Play Component	Edge Restraint	\$32,642.00	\$107,998.89
2038 Total			\$48,467.00	\$160,357.28
2048	SITE COMPONENTS	Landscaping	\$11,325.50	\$70,338.97
2048 Total			\$11,325.50	\$70,338.97
Grand Total			\$285,621.50	\$489,519.41

Description/Life Expectancy		Task	Installed Date	Service Life	Anticipated Replacement Date	Assessments			Evaluated Condition			Estimated Cost Data - 2019						Comments		
Component	Detail		(year)	(years)	(year)	Security (1-5) (0 is lowest)	General (1-5) (0 is lowest)	Accessibility (1-5) (0 is lowest)	Evaluation Date (year)	Life Expectancy Modifier %	Life Expectancy Beyond Evaluation (years remaining) (0 is lowest)	Budget Year	Qty	Units	Prorate	Unit Cost	2019 Replacement Cost (As of Evaluation date)	Escalated Budget		
SITE COMPONENTS						4														
Site Components	Concrete Walks		1998	40	2038		3		2019	0%	0	2038	3,165	sf		\$5.00	\$15,825	\$52,358		
Site Components	Concrete Patios		1998	20	2018		3		2019	10%	2	2020	3,337	sf		\$18.00	\$60,066	\$63,970		
Site Components	Landscaping		1998	50	2048		3		2019	0%	0	2048	45,302	sf		\$0.25	\$11,326	\$70,339		
PLAY COMPONENTS						4														
Play Component	Elevated Structures (2)		1998	15	2013		3	2	2019	46%	7	2020	3	each		\$25,000.00	\$75,000	\$79,374	See Accessibility Chart	
Play Component	Ground Equipment		1998	15	2013		3	2	2019	46%	7	2020	8	each		\$2,500.00	\$20,000	\$21,166	See Accessibility Chart	
Play Component	Mulch		2010	10	2020		3	1	2019	0%	0	2020	11,895	sf		\$5.00	\$59,475	\$63,341		
Play Component	Sand Play Area		2010	10	2020		1	1	2019	0%	0	2020	404	sf		\$47.00	\$18,988	\$20,222		
Play Component	Edge Restraint		1998	40	2038		4		2019	0%	0	2038	859	lf		\$38.00	\$32,642	\$107,999	Plastic Edging	
PARK AMENITIES						4														
Park Amenities	Benches		1998	10	2008		1	2	2019	120%	12	2020	1	each		\$1,000.00	\$1,000	\$1,065		
Park Amenities	Trash/Recycling		1998	10	2008		3	3	2019	120%	12	2020	3	each		\$1,200.00	\$3,600	\$3,834		
Park Amenities	Pavilion		1998	25	2023		3	3	2019	0%	0	2023	827	sf		\$100.00	\$82,700	\$106,391		
						4.00	2.73	2.00							\$380,622	\$590,059				

NOTES

Evaluation of building conditions focused on the elements likely to be included in the budget for items expected to require replacement or renovation within the next 10 to 15 years. Equipment, materials, or assemblies that are nominal in cost are not included. This is therefore not a comprehensive list but does identify major expenses that are likely to be incurred in the foreseeable future.

Conditions change with time, and this evaluation, along with the funds allocated to cover the associated expenses should be reviewed and revised periodically as the Department's needs evolve. Unanticipated expenses can develop for a number of reasons including accelerated use or changes in use patterns, accident, or deferred general maintenance. Such reviews should include updating baseline costs and dates for the components or assemblies identified in this study.

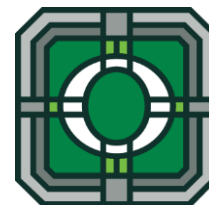
Costs are calculated at 2019 levels and escalated at the following presumed annual rate of inflation:

6.50% per annum

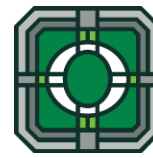
This report is broken up into different categories. The first three are organized by category with like expenses grouped together. The worksheets also covers Mechanical expenses, Electrical expenses, and Plumbing expenses. The last worksheet is organized by the computed year of expense (Budget Year).

Repair/replacement work items do not include A/E Design Fees in the cost.

Total Combined Facilities	
2020	\$152,432
2023	\$106,391
2038	\$160,357
2048	\$70,339
Total:	\$489,519



NAME: EVERGREEN VIEW PARK
ADDRESS: 8610 141st street, Orland Park, IL 60462
PARK TYPE: Neighborhood
EVALUATION YEAR: 2019



PARK MAP:



PARK DATA:

Year Renovated:	2004
Park Age:	15
Total Acreage:	29.4
Total Parking Spaces:	35

Amenities:

Playground Equip: Gametime
 Bike/ Walking Path
 Pavilion
 Picnic Grills

SECURITY COMMENTS:

Score **3.00**

Park security is as to be expected for this size facility. See a few specific areas of note and one concern:
 - Great visibility from public ways
 - Security lighting should be considered if law enforcement has concerns.

ACCESSIBILITY COMMENTS

Score **2.56**

The park amenities were constructed prior to the 2010 Accessibility Code. There are areas of some concern:
 - The large elevated structure is not accessible and would be required to meet current code.
 - the play sand area is not compliant.
 - The bocce ball area is not accessible for players

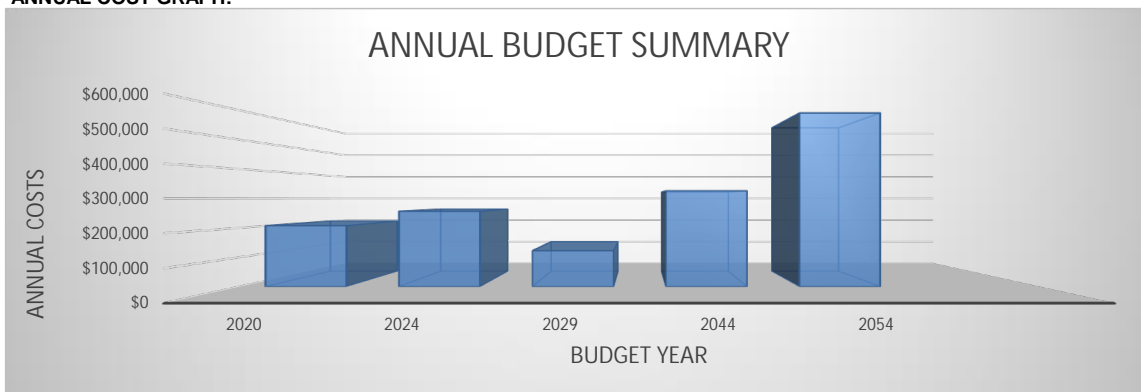
GENERAL CONDITION COMMENTS

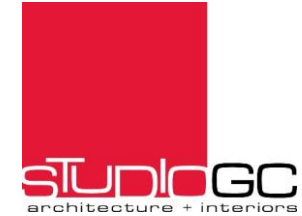
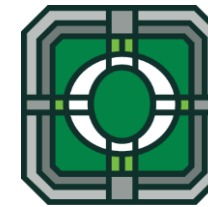
Score **2.67**

The park condition is in alignment with it's age:
 -The play equipment is deteriorated but appears to be cosmetic.
 - The play sand area has sand being carried by water flow to adjacent areas.
 - A drainage evaluation should be conducted to verify the play areas are draining correctly.
 - Fibar is washing out indicating a drainage and grading issue.

Score Average **2.74**

ANNUAL COST GRAPH:





COST BY BUDGET YEAR:

EVERGREEN VIEW PARK

Budget Year	Component	Detail	Values	
			Sum of 2019 Replacement Cost	Sum of Escalated Budget
2020	SITE COMPONENTS	Asphalt - Sealcoat	\$10,230.00	\$10,894.95
		Parking Spaces/Lot (10+1HC)	\$3,500.00	\$3,727.50
	PARK AMENITIES	Benches	\$6,000.00	\$6,390.00
		Trash/Recycling	\$1,200.00	\$1,278.00
	Play Component	Elevated Structures (2)	\$125,000.00	\$133,125.00
		Ground Equipment	\$12,500.00	\$13,312.50
		Mulch	\$36,195.00	\$38,547.68
2020 Total			\$194,625.00	\$207,275.63
2024	SITE COMPONENTS	Concrete Patios	\$49,194.00	\$67,400.04
	PARK AMENITIES	Park Lighting	\$2,500.00	\$3,425.22
	Play Component	Edge Restraint	\$20,406.00	\$27,957.99
	RECREATION COMPONENTS	Basketball Courts	\$115,000.00	\$157,559.97
		Bocce Ball	\$0.00	\$0.00
2024 Total			\$187,100.00	\$256,343.21
2029	PARK AMENITIES	Pavillion	\$65,100.00	\$122,201.65
2029 Total			\$65,100.00	\$122,201.65
2044	SITE COMPONENTS	Concrete Walks	\$67,475.00	\$325,749.00
2044 Total			\$67,475.00	\$325,749.00
2054	SITE COMPONENTS	Landscaping	\$65,165.76	\$590,548.73
2054 Total			\$65,165.76	\$590,548.73
Grand Total			\$579,465.76	\$1,502,118.21

Description/Life Expectancy						Assessments			Evaluated Condition			Estimated Cost Data - 2019						Comments	
Component	Detail	Task	Installed Date	Service Life	Anticipated Replacement Date	Security (1-5)	General (1-5)	Accessibility (1-5)	Evaluation Date	Life Expectancy Modifier	Life Expectancy Beyond Evaluation (years remaining)	Budget Year	Qty	Units	Prorate	Unit Cost	2019 Replacement Cost		Escalated Budget
			(year)	(years)	(year)	(0 is lowest)	(0 is lowest)	(0 is lowest)	(year)	%	(0 is lowest)						(As of Evaluation date)		
SITE COMPONENTS						3													
Site Components	Asphalt - Sealcoat		2017	2	2019		2	4	2019	50%	1	2020	10,230	sf		\$1.00	\$10,230	\$10,895	
Site Components	Concrete Walks		2004	40	2044		2	2	2019	0%	0	2044	13,495	sf		\$5.00	\$67,475	\$325,749	
Site Components	Concrete Patios		2004	20	2024		2		2019	0%	0	2024	2,733	sf		\$18.00	\$49,194	\$67,400	
Site Components	Landscaping		2004	50	2054		3		2019	0%	0	2054	814,572	sf		\$0.08	\$65,166	\$590,549	
Site Components	Parking Spaces/Lot (10+1HC)		2017	2	2019		3		2019	50%	1	2020	35	each		\$100.00	\$3,500	\$3,728	
PLAY COMPONENTS																			
Play Component	Elevated Structures (2)		2004	15	2019		4	1	2019	6%	1	2020	5	each		\$25,000.00	\$125,000	\$133,125	
Play Component	Ground Equipment		2004	15	2019		2	3	2019	6%	1	2020	5	each		\$2,500.00	\$12,500	\$13,313	
Play Component	Mulch		2010	10	2020		2	3	2019	0%	0	2020	7,239	sf		\$5.00	\$36,195	\$38,548	
Play Component	Edge Restraint		2004	40	2044		4		2019	-50%	-20	2024	537	lf		\$38.00	\$20,406	\$27,958	
PARK AMENITIES																			
Park Amenities	Park Lighting		2004	20	2024		3		2019	0%	0	2024	1	each		\$2,500.00	\$2,500	\$3,425	
Park Amenities	Benches		2004	10	2014		3	2	2019	60%	6	2020	6	each		\$1,000.00	\$6,000	\$6,390	
Park Amenities	Trash/Recycling		2004	10	2014		3		2019	60%	6	2020	3	each		\$400.00	\$1,200	\$1,278	
Park Amenities	Pavillion		2004	25	2029		4	4	2019	0%	0	2029	651	sf		\$100.00	\$65,100	\$122,202	
RECREATION COMPONENTS																			
Recreation Components	Basketball Courts		2004	20	2024		2	3	2019	0%	0	2024	1	each		\$115,000.00	\$115,000	\$157,560	
Recreation Components	Bocce Ball		2004	20	2024		1	1	2019	0%	0	2024	0	each		\$115,000.00	\$0	\$0	
						3.00	2.67	2.56									\$579,466	\$1,502,118	

NOTES

Evaluation of building conditions focused on the elements likely to be included in the budget for items expected to require replacement or renovation within the next 10 to 15 years. Equipment, materials, or assemblies that are nominal in cost are not included. This is therefore not a comprehensive list but does identify major expenses that are likely to be incurred in the foreseeable future.

Conditions change with time, and this evaluation, along with the funds allocated to cover the associated expenses should be reviewed and revised periodically as the Department's needs evolve. Unanticipated expenses can develop for a number of reasons including accelerated use or changes in use patterns, accident, or deferred general maintenance. Such reviews should include updating baseline costs and dates for the components or assemblies identified in this study.

Costs are calculated at 2019 levels and escalated at the following presumed annual rate of inflation:

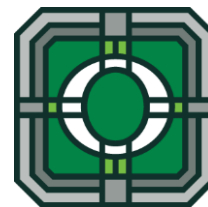
6.50% per annum

This report is broken up into different categories. The first three are organized by category with like expenses grouped together. The worksheets also covers Mechanical expenses, Electrical expenses, and Plumbing expenses. The last worksheet is organized by the computed year of expense (Budget Year).

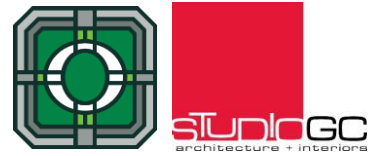
Repair/replacement work items do not include A/E Design Fees in the cost.

Total Combined Facilities

2020	\$207,276
2024	\$256,343
2029	\$122,202
2044	\$325,749
2054	\$590,549
Total:	\$1,502,118



NAME: FOUNTAIN HILLS PARK
ADDRESS: 108th Ave & Buckingham Dr, Orland Park, IL 60462
PARK TYPE: Neighborhood
EVALUATION YEAR: 2019



PARK MAP:



PARK DATA:

Year Renovated:	2007
Park Age:	12
Total Acreage:	5.2
Total Parking Spaces:	0

Amenities:
 Playground Equip: Gametime
 Basketball Court
 Pavilion

SECURITY COMMENTS:

Score 3.00

Park security is as to be expected for this size facility. See a few specific areas of note and one concern:
 - Great visibility from public ways
 - Security lighting should be considered if law enforcement has concerns.

ACCESSIBILITY COMMENTS

Score 2.89

This park is more accessible than would be expected for it's age.
 - The sand area is not accessible
 - Sidewalks provide a appropriate accessibility and are generally free from heaving.
 - Playground equipment will require additional evaluation to determine ADA compliance

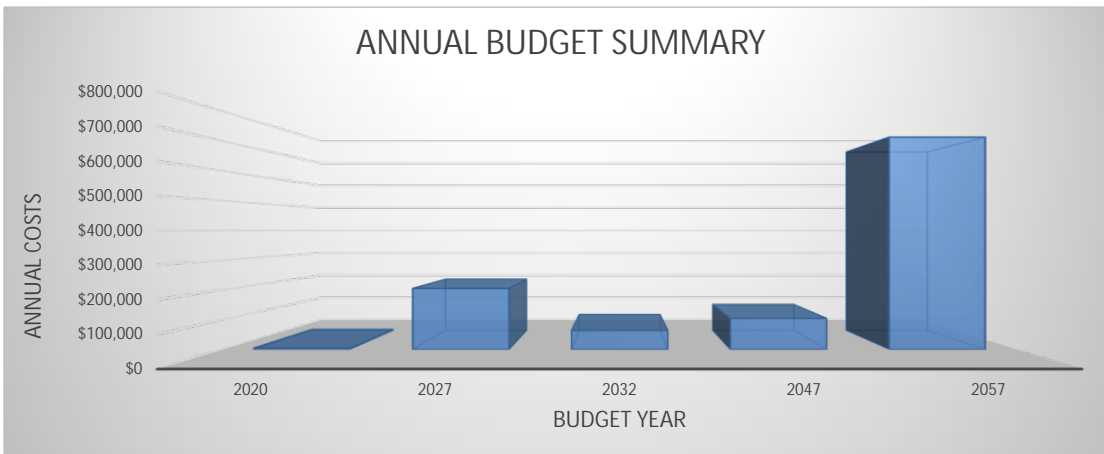
GENERAL CONDITION COMMENTS

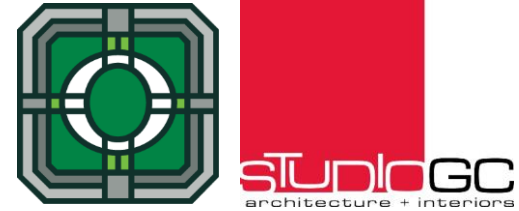
Score 3.18

The park is in good condition but there are a few items to note:
 - The amenities do not appear to be deteriorating faster than anticipated.
 - The walkways have some sizable cracks.
 - Pavilion appears to be in good condition but should be monitored to verify deterioration does not become a structural concern or detract from it's use.
 - Basketball court seems to have indications of ponding which will shorten it's overall lifespan

Score Average 3.02

ANNUAL COST GRAPH:





COST BY BUDGET YEAR:

FOUNTAIN HILLS PARK

Budget Year	Component	Detail	Values	
			Sum of 2019 Replacement Cost	Sum of Escalated Budget
2020	PARK AMENITIES	Benches	\$4,000.00	\$4,260.00
		Trash/Recycling	\$400.00	\$426.00
2020 Total			\$4,400.00	\$4,686.00
2027	SITE COMPONENTS	Concrete Patios	\$8,964.00	\$14,835.38
	RECREATION COMPONENTS	Basketball Courts	\$115,000.00	\$190,324.50
2027 Total			\$123,964.00	\$205,159.88
2032	PARK AMENITIES	Pavilion	\$28,300.00	\$64,169.90
2032 Total			\$28,300.00	\$64,169.90
2047	SITE COMPONENTS	Concrete Walks	\$5,220.00	\$30,441.04
	Play Component	Edge Restraint	\$12,654.00	\$73,793.29
2047 Total			\$17,874.00	\$104,234.33
2057	SITE COMPONENTS	Landscaping	\$65,165.76	\$713,353.11
2057 Total			\$65,165.76	\$713,353.11
Grand Total			\$239,703.76	\$1,091,603.22

FOUNTAIN HILLS PARK		108th Ave & Buckingham Dr, Orland Park, IL 60462				Assessments			Evaluated Condition			Estimated Cost Data - 2019						Comments	
Description/Life Expectancy		Task	Installed Date	Service Life	Anticipated Replacement Date	Security (1-5)	General (1-5)	Accessibility (1-5)	Evaluation Date	Life Expectancy Modifier	Life Expectancy Beyond Evaluation (years remaining)	Budget Year	Qty	Units	Prorate	Unit Cost	2019 Replacement Cost		Escalated Budget
Component	Detail		(year)	(years)	(year)	(0 is lowest)	(0 is lowest)	(0 is lowest)	(year)	%	(0 is lowest)						(As of Evaluation date)		
SITE COMPONENTS						3													
Site Components	Concrete Walks		2007	40	2047		2	3	2019	0%	0	2047	1,044	sf		\$5.00	\$5,220	\$30,441	
Site Components	Concrete Patios		2007	20	2027		3	3	2019	0%	0	2027	498	sf		\$18.00	\$8,964	\$14,835	
Site Components	Landscaping		2007	50	2057		3		2019	0%	0	2057	814,572	sf		\$0.08	\$65,166	\$713,353	
PLAY COMPONENTS																			
Play Component	Elevated Structures (2)		2007	15	2022		3	4	2019	4%	1	2023	3	each		\$25,000.00	\$75,000	\$94,085	See Accessibility Chart
Play Component	Ground Equipment		2007	15	2022		3	3	2019	4%	1	2023	4	each		\$2,500.00	\$10,000	\$12,545	See Accessibility Chart
Play Component	Mulch		2007	10	2017		4	2	2019	5%	1	2018	5,412	sf		\$5.00	\$27,060	\$24,621	
Play Component	Edge Restraint		2007	40	2047		5		2019	0%	0	2047	333	lf		\$38.00	\$12,654	\$73,793	Plastic Edging
PARK AMENITIES																			
Park Amenities	Benches		2007	10	2017		3	2	2019	30%	3	2020	4	each		\$1,000.00	\$4,000	\$4,260	
Park Amenities	Trash/Recycling		2007	10	2017		3	3	2019	30%	3	2020	1	each		\$400.00	\$400	\$426	
Park Amenities	Pavilion		2007	25	2032		4	3	2019	0%	0	2032	283	sf		\$100.00	\$28,300	\$64,170	
RECREATION COMPONENTS																			
Recreation Components	Basketball Courts		2007	20	2027		2	3	2019	0%	0	2027	1	each		\$115,000.00	\$115,000	\$190,325	
						3.00	3.18	2.89							\$351,764	\$1,222,854			

NOTES

Evaluation of building conditions focused on the elements likely to be included in the budget for items expected to require replacement or renovation within the next 10 to 15 years. Equipment, materials, or assemblies that are nominal in cost are not included. This is therefore not a comprehensive list but does identify major expenses that are likely to be incurred in the foreseeable future.

Conditions change with time, and this evaluation, along with the funds allocated to cover the associated expenses should be reviewed and revised periodically as the Department's needs evolve. Unanticipated expenses can develop for a number of reasons including accelerated use or changes in use patterns, accident, or deferred general maintenance. Such reviews should include updating baseline costs and dates for the components or assemblies identified in this study.

Costs are calculated at 2019 levels and escalated at the following presumed annual rate of inflation:

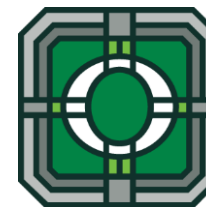
6.50% per annum

This report is broken up into different categories. The first three are organized by category with like expenses grouped together. The worksheets also covers Mechanical expenses, Electrical expenses, and Plumbing expenses. The last worksheet is organized by the computed year of expense (Budget Year).

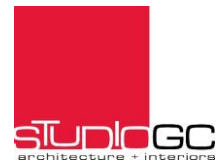
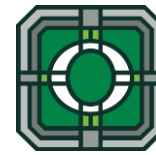
Repair/replacement work items do not include A/E Design Fees in the cost.

Total Combined Facilities

2020	\$4,686
2027	\$205,160
2032	\$64,170
2047	\$104,234
2057	\$713,353
Total:	\$1,091,603



NAME: FRONTIER PARK
ADDRESS: 9740 144th Place, Orland Park, IL 60462
PARK TYPE: Mini
EVALUATION YEAR: 2019



PARK MAP:



PARK DATA:

Year Renovated:	1996
Park Age:	23
Total Acreage:	1.2
Total Parking Spaces:	11

Amenities:

Playground Equip: Burke
 Pavilion
 Picnic Grill

SECURITY COMMENTS:

Score **3.00**

Park security is as to be expected for this size facility. See a few specific areas of note and one concern:

- Great visibility from public ways
- Security lighting should be considered if law enforcement has concerns.

ACCESSIBILITY COMMENTS

Score **3.14**

The park was constructed prior to the 2010 Accessibility Code however seems to be generally compliant. A full analysis needs to be completed to verify compliance.

- The sand pit is not compliant.
- Mulch should be reviewed to meet compliance from an accessibility and safety point of view

GENERAL CONDITION COMMENTS

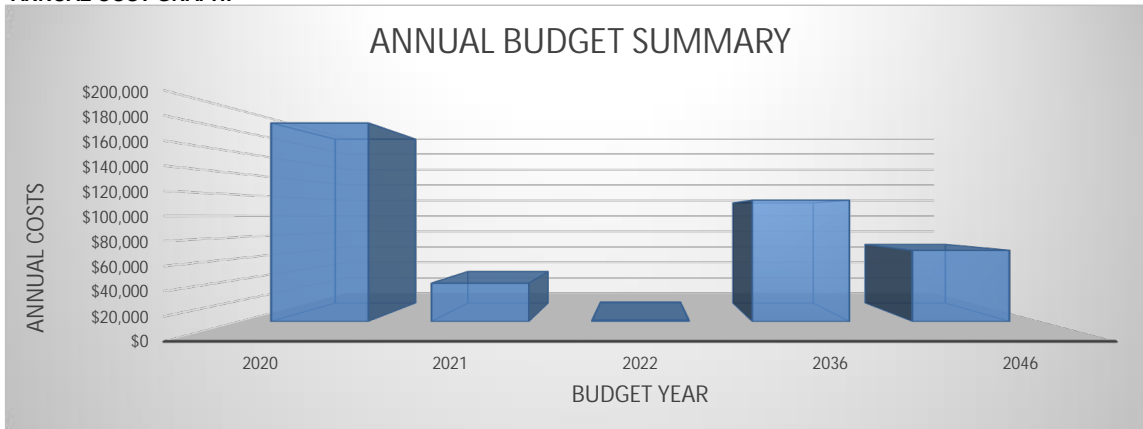
Score **3.25**

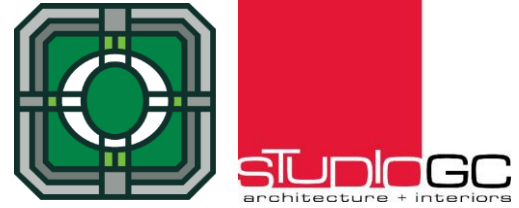
Park is in good condition and there are no concerns.

- All deterioration appears to be cosmetic.
- Sand Pit is well isolated but is past its useful life.
- Concrete block retaining walls should be reviewed, they are loose at other parks.
- Occasional flooding indicating drainage and grading issues.

Score Average **3.13**

ANNUAL COST GRAPH:





COST BY BUDGET YEAR:

FRONTIER PARK

Budget Year	Component	Detail	Values	
			Sum of 2019 Replacement Cost	Sum of Escalated Budget
2020	SITE COMPONENTS	Concrete Patios	\$32,328.00	\$34,429.32
		Asphalt - Sealcoat	\$10,032.00	\$10,684.08
	PARK AMENITIES	Benches	\$5,000.00	\$5,325.00
		Trash/Recycling	\$1,200.00	\$1,278.00
	Play Component	Elevated Structures (2)	\$75,000.00	\$79,875.00
		Ground Equipment	\$15,000.00	\$15,975.00
		Mulch	\$34,915.00	\$37,184.48
		Sand Play Area	\$3,000.00	\$3,195.00
2020 Total			\$176,475.00	\$187,945.88
2021	PARK AMENITIES	Pavilion	\$32,000.00	\$36,295.20
2021 Total			\$32,000.00	\$36,295.20
2022	SITE COMPONENTS	Parking Spaces/Lot (10+1HC)	\$1,100.00	\$1,328.74
2022 Total			\$1,100.00	\$1,328.74
2036	SITE COMPONENTS	Concrete Walks	\$17,850.00	\$52,069.28
	Play Component	Edge Restraint	\$21,546.00	\$62,850.68
2036 Total			\$39,396.00	\$114,919.96
2046	SITE COMPONENTS	Landscaping	\$12,305.70	\$67,382.28
2046 Total			\$12,305.70	\$67,382.28
Grand Total			\$261,276.70	\$407,872.06

Description/Life Expectancy						Assessments			Evaluated Condition			Estimated Cost Data - 2019								
Component	Detail	Task	Installed Date	Service Life	Anticipated Replacement Date	Security (1-5)	General (1-5)	Accessibility (1-5)	Evaluation Date	Life Expectancy Modifier	Life Expectancy Beyond Evaluation (years remaining)	Budget Year	Qty	Units	Prorate	Unit Cost	2019 Replacement Cost	Escalated Budget	Comments	
			(year)	(years)	(year)	(0 is lowest)	(0 is lowest)	(0 is lowest)	(year)	%	(0 is lowest)						(As of Evaluation date)			
SITE COMPONENTS						3														
Site Components	Asphalt - Sealcoat		2017	2	2019				2019	50%	1	2020	10,032	sf		\$1.00	\$10,032	\$10,684		
Site Components	Concrete Walks		1996	40	2036		3	3	2019	0%	0	2036	3,570	sf		\$5.00	\$17,850	\$52,069		
Site Components	Concrete Patios		1996	20	2016		3	3	2019	20%	4	2020	1,796	sf		\$18.00	\$32,328	\$34,429		
Site Components	Landscaping		1996	50	2046		3		2019	0%	0	2046	49,223	sf		\$0.25	\$12,306	\$67,382		
Site Components	Parking Spaces/Lot (10+1HC)		2017	5	2022		4		2019	0%	0	2022	11	each		\$100.00	\$1,100	\$1,329	2 Handicapped	
PLAY COMPONENTS																				
Play Component	Elevated Structures (2)		1996	15	2011		3	4	2019	60%	9	2020	3	each		\$25,000.00	\$75,000	\$79,875	See Accessibility Chart	
Play Component	Ground Equipment		1996	15	2011		3	4	2019	60%	9	2020	6	each		\$2,500.00	\$15,000	\$15,975	See Accessibility Chart	
Play Component	Mulch		2010	10	2020		3	3	2019	0%	0	2020	6,983	sf		\$5.00	\$34,915	\$37,184		
Play Component	Sand Play Area		2010	10	2020		3	1	2019	0%	0	2020	600	sf		\$5.00	\$3,000	\$3,195		
Play Component	Edge Restraint		1996	40	2036		5		2019	0%	0	2036	567	lf		\$38.00	\$21,546	\$62,851	Plastic Edging	
PARK AMENITIES																				
Park Amenities	Benches		1996	10	2006		3		2019	140%	14	2020	5	each		\$1,000.00	\$5,000	\$5,325		
Park Amenities	Trash/Recycling		1996	10	2006		3		2019	140%	14	2020	3	each		\$400.00	\$1,200	\$1,278		
Park Amenities	Pavilion		1996	25	2021		3	4	2019	0%	0	2021	320	sf		\$100.00	\$32,000	\$36,295		
RECREATION COMPONENTS																				
						3.00	3.25	3.14									\$261,277	\$407,872		

NOTES

Evaluation of building conditions focused on the elements likely to be included in the budget for items expected to require replacement or renovation within the next 10 to 15 years. Equipment, materials, or assemblies that are nominal in cost are not included. This is therefore not a comprehensive list but does identify major expenses that are likely to be incurred in the foreseeable future.

Conditions change with time, and this evaluation, along with the funds allocated to cover the associated expenses should be reviewed and revised periodically as the districts' needs evolve. Unanticipated expenses can develop for a number of reasons including accelerated use or changes in use patterns, accident, or deferred general maintenance. Such reviews should include updating baseline costs and dates for the components or assemblies identified in this study.

Costs are calculated at 2019 levels and escalated at the following presumed annual rate of inflation:

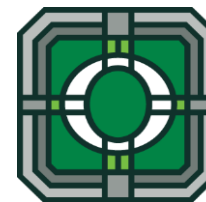
6.50% per annum

This report is broken up into different categories. The first three are organized by category with like expenses grouped together. The worksheets also covers Mechanical expenses, Electrical expenses, and Plumbing expenses. The last worksheet is organized by the computed year of expense (Budget Year).

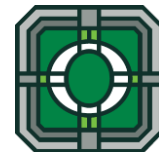
Repair/replacement work items do not include A/E Design Fees in the cost.

Total Combined Facilities

2020	\$187,946
2021	\$36,295
2022	\$1,329
2036	\$114,920
2046	\$67,382
Total	\$407,872



NAME: GEORGETOWN PARK
ADDRESS: 9400 Providence Sq, Orland Park, IL 60462
PARK TYPE: Mini
EVALUATION YEAR: 2019



PARK MAP:



PARK DATA:

Year Renovated:	2003
Park Age:	16
Total Acreage:	2.2
Total Parking Spaces:	0

Amenities:

Playground Equip: Gametime
 Pavilion
 Picnic Grill

SECURITY COMMENTS:

Score **3.00**

- Park security is as to be expected for this size facility. See a few specific areas of note and one concern:
- Great visibility from public ways
 - Security lighting should be considered if law enforcement has concerns.

ACCESSIBILITY COMMENTS

Score **2.75**

- The park was constructed prior to the 2010 Accessibility Code revisions. A full study should be completed but other elements of accessibility in the park appears to be compliant.
- Mulch area ramp is not in keeping with current standards.
 - Mulch/Engineered wood fiber is over compacted or deteriorated and may be effecting fall protection.

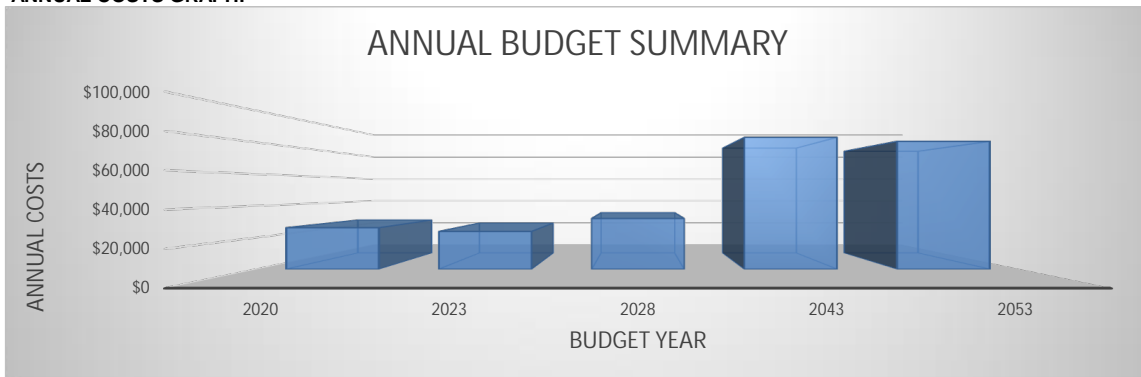
GENERAL CONDITION COMMENTS

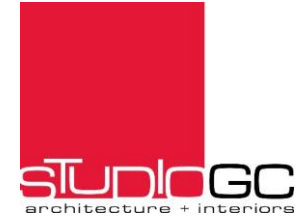
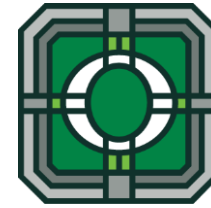
Score **3.20**

- The park is in generally good condition.
- All deterioration appears to be cosmetic.
 - Engineer wood fiber needs to be refreshed.
 - Some exposed rusted areas on ground equipment and missing caps, must be addressed ASAP.
 - Brick pavers need to be reset and re-sanded.

Score Average **2.98**

ANNUAL COSTS GRAPH:





COST BY BUDGET YEAR:

GEORGETOWN PARK

Budget Year	Component	Detail	Values	
			Sum of 2019 Replacement Cost	Sum of Escalated Budget
2020	PARK AMENITIES	Benches	\$4,000.00	\$4,260.00
		Trash/Recycling	\$400.00	\$426.00
	Play Component	Mulch	\$20,200.00	\$21,513.00
2020 Total			\$24,600.00	\$26,199.00
2023	SITE COMPONENTS	Concrete Patios	\$18,522.00	\$23,827.93
2023 Total			\$18,522.00	\$23,827.93
2028	PARK AMENITIES	Pavilion	\$18,150.00	\$31,990.65
2028 Total			\$18,150.00	\$31,990.65
2043	SITE COMPONENTS	Concrete Walks	\$8,042.50	\$36,457.06
	Play Component	Edge Restraint	\$10,298.00	\$46,681.36
2043 Total			\$18,340.50	\$83,138.42
2053	SITE COMPONENTS	Landscaping	\$9,474.25	\$80,617.90
2053 Total			\$9,474.25	\$80,617.90
Grand Total			\$89,086.75	\$245,773.91

Description/Life Expectancy		Task	Installed Date	Service Life	Anticipated Replacement Date	Assessments			Evaluated Condition			Estimated Cost Data - 2019						Comments		
Component	Detail		(year)	(years)	(year)	Security (1-5)	General (1-5)	Accessibility (1-5)	Evaluation Date	Life Expectancy Modifier	Life Expectancy Beyond Evaluation (years remaining)	Budget Year	Qty	Units	Prorate	Unit Cost	2019 Replacement Cost	Escalated Budget		
						(0 is lowest)	(0 is lowest)	(0 is lowest)	(year)	%	(0 is lowest)						(As of Evaluation date)			
SITE COMPONENTS						3														
Site Components	Concrete Walks		2003	40	2043		4	3	2019	0%	0	2043	1,609	sf		\$5.00	\$8,043	\$36,457		
Site Components	Concrete Patios		2003	20	2023		4	3	2019	0%	0	2023	1,029	sf		\$18.00	\$18,522	\$23,828		
Site Components	Landscaping		2003	50	2053		3		2019	0%	0	2053	37,897	sf		\$0.25	\$9,474	\$80,618		
PLAY COMPONENTS																				
Play Component	Elevated Structures (2)		2003	15	2018		2	3	2019	12%	2	2020	4	each		\$25,000.00	\$100,000	\$105,167	See Accessibility Chart	
Play Component	Ground Equipment		2003	15	2018		2	3	2019	12%	2	2020	4	each		\$2,500.00	\$10,000	\$10,517	See Accessibility Chart	
Play Component	Mulch		2010	10	2020		2	2	2019	0%	0	2020	4,040	sf		\$5.00	\$20,200	\$21,513		
Play Component	Edge Restraint		2003	40	2043		5		2019	0%	0	2043	271	lf		\$38.00	\$10,298	\$46,681	Plastic Edging	
PARK AMENITIES																				
Park Amenities	Benches		2003	10	2013		3	2	2019	70%	7	2020	4	each		\$1,000.00	\$4,000	\$4,260		
Park Amenities	Trash/Recycling		2003	10	2013		3	3	2019	70%	7	2020	1	each		\$400.00	\$400	\$426		
Park Amenities	Pavilion		2003	25	2028		4	3	2019	0%	0	2028	182	sf		\$100.00	\$18,150	\$31,991		
						3.00	3.20	2.75									\$199,087	\$361,458		

NOTES

Evaluation of building conditions focused on the elements likely to be included in the budget for items expected to require replacement or renovation within the next 10 to 15 years. Equipment, materials, or assemblies that are nominal in cost are not included. This is therefore not a comprehensive list but does identify major expenses that are likely to be incurred in the foreseeable future.

Conditions change with time, and this evaluation, along with the funds allocated to cover the associated expenses should be reviewed and revised periodically as the Department's needs evolve. Unanticipated expenses can develop for a number of reasons including accelerated use or changes in use patterns, accident, or deferred general maintenance. Such reviews should include updating baseline costs and dates for the components or assemblies identified in this study.

Costs are calculated at 2019 levels and escalated at the following presumed annual rate of inflation:

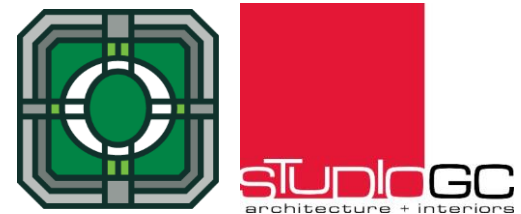
6.50% per annum

This report is broken up into different categories. The first three are organized by category with like expenses grouped together. The worksheets also covers Mechanical expenses, Electrical expenses, and Plumbing expenses. The last worksheet is organized by the computed year of expense (Budget Year).

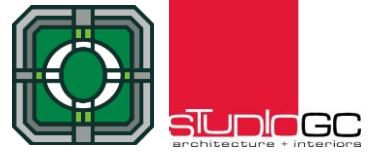
Repair/replacement work items do not include A/E Design Fees in the cost.

Total Combined Facilities

2020	\$26,199
2023	\$23,828
2028	\$31,991
2043	\$83,138
2053	\$80,618
Total:	\$245,774



NAME: GRASSLANDS PARK
ADDRESS: 17050 Steeplechase Parkway, Orland Park, IL 60462
PARK TYPE: Neighborhood
EVALUATION YEAR: 2019



PARK MAP:



PARK DATA:

Year Renovated:	2008
Park Age:	11
Total Acreage:	2.4
Total Parking Spaces:	0

Amenities:

Playground Equip: Gametime
 Basketball Court
 Bike/ Walking Path
 Pavilion

SECURITY COMMENTS:

Park security is as to be expected for this size facility. See a few specific areas of note and one concern:
 - Great visibility from public ways
 - Security lighting should be considered if law enforcement has concerns.

Score **3.00**

ACCESSIBILITY COMMENTS

Park was created prior to the 2010 ADA accessibility code. Though elements of the play structure are compliant a full study is recommended.
 - ADA ramps into play area have heaved and are not accessible.
 - Sand area is not considered accessible.
 - Elevated play area has accessible ramp.
 - Sport areas are not accessible

Score **2.89**

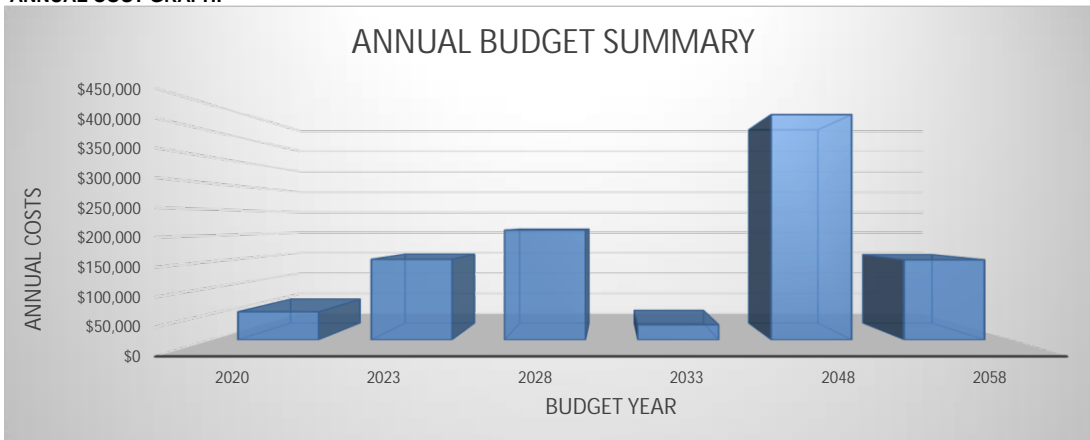
GENERAL CONDITION COMMENTS

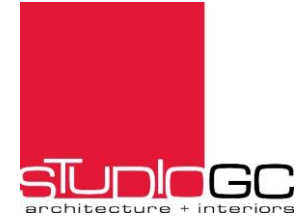
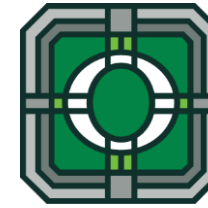
Park is in good condition and no particular concerns about areas aging unexpectedly.
 - Paved areas are deteriorating.
 - Play equipment has deteriorate finishes and some vandalism.
 - Basketball court is significantly deteriorated.

Score **2.92**

Score Average **2.94**

ANNUAL COST GRAPH:





COST BY BUDGET YEAR:

GRASSLANDS PARK

Budget Year	Component	Detail	Values	
			Sum of 2019 Replacement Cost	Sum of Escalated Budget
2020	PARK AMENITIES	Benches	\$2,000.00	\$2,130.00
		Trash/Recycling	\$800.00	\$852.00
	Play Component	Mulch	\$45,814.95	\$48,792.92
		Sand Area	\$2,000.00	\$2,130.00
2020 Total			\$50,614.95	\$53,904.92
2023	Play Component	Elevated Structures (2)	\$100,000.00	\$128,646.64
		Ground Equipment	\$20,000.00	\$25,729.33
2023 Total			\$120,000.00	\$154,375.96
2028	SITE COMPONENTS	Concrete Patios	\$4,269.60	\$7,525.47
	RECREATION COMPONENTS	Basketball Courts	\$115,000.00	\$202,695.59
2028 Total			\$119,269.60	\$210,221.07
2033	PARK AMENITIES	Pavilion	\$12,000.00	\$28,978.49
2033 Total			\$12,000.00	\$28,978.49
2048	SITE COMPONENTS	Concrete Walks	\$47,300.00	\$293,764.81
	Play Component	Edge Restraint	\$22,192.00	\$137,827.24
2048 Total			\$69,492.00	\$431,592.05
2058	SITE COMPONENTS	Landscaping	\$13,155.10	\$153,365.92
2058 Total			\$13,155.10	\$153,365.92
Grand Total			\$384,531.65	\$1,032,438.41

Description/Life Expectancy		Task	Installed Date	Service Life	Anticipated Replacement Date	Assessments			Evaluated Condition			Estimated Cost Data - 2019						Comments	
Component	Detail		(year)	(years)	(year)	Security (1-5)	General (1-5)	Accessibility (1-5)	Evaluation Date	Life Expectancy Modifier	Life Expectancy Beyond Evaluation (years remaining)	Budget Year	Qty	Units	Prorate	Unit Cost	2019 Replacement Cost	Escalated Budget	
						(0 is lowest)	(0 is lowest)	(0 is lowest)	(year)	%	(0 is lowest)						(As of Evaluation date)		
SITE COMPONENTS																			
						3													
Site Components	Concrete Walks		2008	40	2048		3	3	2019	0%	0	2048	9,460	sf		\$5.00	\$47,300	\$293,765	
Site Components	Concrete Patios		2008	20	2028		3	3	2019	0%	0	2028	237	sf		\$18.00	\$4,270	\$7,525	
Site Components	Landscaping		2008	50	2058		3		2019	0%	0	2058	131,551	sf		\$0.10	\$13,155	\$153,366	
PLAY COMPONENTS																			
Play Component	Elevated Structures (2)		2008	15	2023		3	5	2019	0%	0	2023	4	each		\$25,000.00	\$100,000	\$128,647	See Accessibility Chart
Play Component	Ground Equipment		2008	15	2023		3	3	2019	0%	0	2023	8	each		\$2,500.00	\$20,000	\$25,729	See Accessibility Chart
Play Component	Mulch		2010	10	2020		4	4	2019	0%	0	2020	9,163	sf		\$5.00	\$45,815	\$48,793	
Play Component	Sand Area		2010	10	2020		2	1	2019	0%	0	2020	400	sf		\$5.00	\$2,000	\$2,130	
Play Component	Edge Restraint		2008	40	2048		4		2019	0%	0	2048	584	lf		\$38.00	\$22,192	\$137,827	Plastic Edging
PARK AMENITIES																			
Park Amenities	Benches		2008	10	2018		2	3	2019	20%	2	2020	2	each		\$1,000.00	\$2,000	\$2,130	
Park Amenities	Trash/Recycling		2008	10	2018		3		2019	20%	2	2020	2	each		\$400.00	\$800	\$852	
Park Amenities	Pavilion		2008	25	2033		3	3	2019	0%	0	2033	120	sf		\$100.00	\$12,000	\$28,978	
RECREATION COMPONENTS																			
Recreation Components	Basketball Courts		2008	20	2028		2	1	2019	0%	0	2028	1	each		\$115,000.00	\$115,000	\$202,696	
						3.00	2.92	2.89							\$384,532	\$1,032,438			

NOTES

Evaluation of building conditions focused on the elements likely to be included in the budget for items expected to require replacement or renovation within the next 10 to 15 years. Equipment, materials, or assemblies that are nominal in cost are not included. This is therefore not a comprehensive list but does identify major expenses that are likely to be incurred in the foreseeable future.

Conditions change with time, and this evaluation, along with the funds allocated to cover the associated expenses should be reviewed and revised periodically as the Department's needs evolve. Unanticipated expenses can develop for a number of reasons including accelerated use or changes in use patterns, accident, or deferred general maintenance. Such reviews should include updating baseline costs and dates for the components or assemblies identified in this study.

Costs are calculated at 2019 levels and escalated at the following presumed annual rate of inflation:

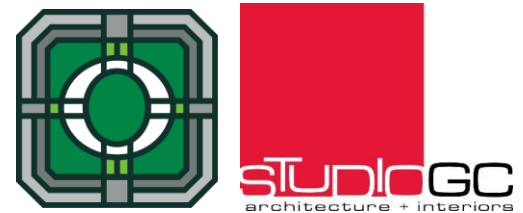
6.50% per annum

This report is broken up into different categories. The first three are organized by category with like expenses grouped together. The worksheets also covers Mechanical expenses, Electrical expenses, and Plumbing expenses. The last worksheet is organized by the computed year of expense (Budget Year).

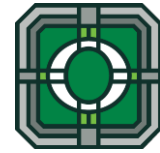
Repair/replacement work items do not include A/E Design Fees in the cost.

Total Combined Facilities

2020	\$53,905
2023	\$154,376
2028	\$210,221
2033	\$28,978
2048	\$431,592
2058	\$153,366
Total:	\$1,032,438



NAME: GREYSTONE PARK
ADDRESS: 13830 Creek Crossing Drive, Orland Park, IL 60462
PARK TYPE: Neighborhood
EVALUATION YEAR: 2019



PARK MAP:



PARK DATA:

Year Renovated:	2016
Park Age:	3
Total Acreage:	0.52
Total Parking Spaces:	0

Amenities:

Playground Equip: Landscape Struct.
 Basketball Court
 Bike/ Walking Path
 Pavilion
 Fishing
 Bean Bag Boards

SECURITY COMMENTS:

Park security is as to be expected for this size facility. See a few specific areas of note and one concern:
 - Great visibility from public ways
 - Security lighting should be considered if law enforcement has concerns.

Score **3.00**

ACCESSIBILITY COMMENTS

The park is only a few years old and appears to be designed in keeping with the 2010 Accessibility Guidelines. The only comments is that the fiber surface does not appear to have the proper ramps into the play area.

Score **3.63**

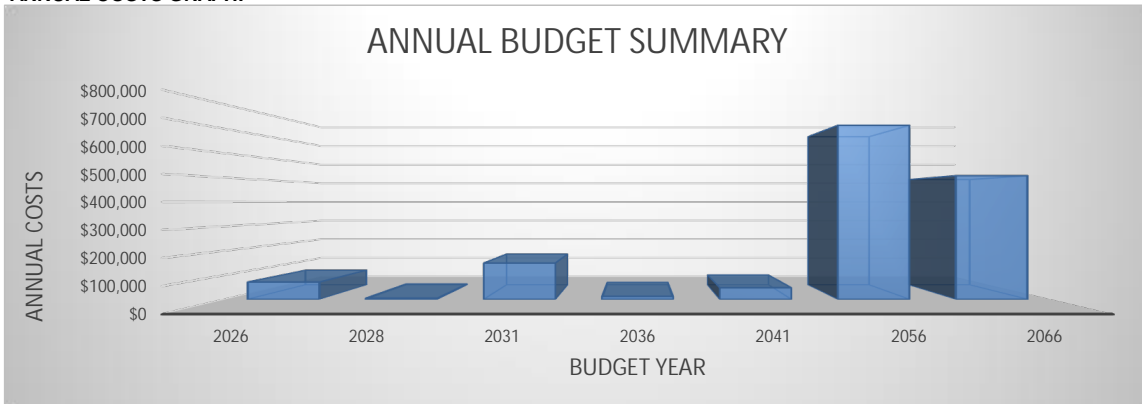
GENERAL CONDITION COMMENTS

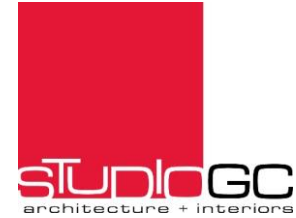
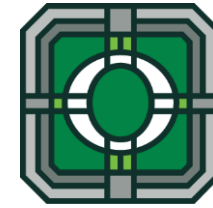
Park amenities are new. No concerns

Score **5.00**

Score Average **3.88**

ANNUAL COSTS GRAPH:





COST BY BUDGET YEAR:

GREYSTONE PARK

Budget Year	Component	Detail	Values	
			Sum of 2019 Replacement Cost	Sum of Escalated Budget
2026	Play Component	Mulch	\$45,814.95	\$71,195.82
2026 Total			\$45,814.95	\$71,195.82
2028	PARK AMENITIES	Benches	\$2,000.00	\$3,525.14
		Trash/Recycling	\$800.00	\$1,410.06
2028 Total			\$2,800.00	\$4,935.20
2031	Play Component	Elevated Structures (2)	\$50,000.00	\$106,454.81
		Ground Equipment	\$20,000.00	\$42,581.92
2031 Total			\$70,000.00	\$149,036.74
2036	SITE COMPONENTS	Concrete Patios	\$4,269.60	\$12,454.62
2036 Total			\$4,269.60	\$12,454.62
2041	PARK AMENITIES	Pavilion	\$12,000.00	\$47,959.28
2041 Total			\$12,000.00	\$47,959.28
2056	SITE COMPONENTS Play Component	Concrete Walks	\$47,300.00	\$486,179.48
		Edge Restraint	\$22,192.00	\$228,103.49
2056 Total			\$69,492.00	\$714,282.97
2066	SITE COMPONENTS	Landscaping	\$26,310.20	\$507,639.86
2066 Total			\$26,310.20	\$507,639.86
Grand Total			\$230,686.75	\$1,507,504.48

GREYSTONE PARK		13830 Creek Crossing Drive, Orland Park, IL 60462				Assessments			Evaluated Condition			Estimated Cost Data - 2019						Comments	
Description/Life Expectancy		Task	Installed Date	Service Life	Anticipated Replacement Date	Security (1-5)	General (1-5)	Accessibility (1-5)	Evaluation Date	Life Expectancy Modifier	Life Expectancy Beyond Evaluation (years remaining)	Budget Year	Qty	Units	Prorate	Unit Cost	2019 Replacement Cost		Escalated Budget
Component	Detail		(year)	(years)	(year)	(0 is lowest)	(0 is lowest)	(0 is lowest)	(year)	%	(0 is lowest)						(As of Evaluation date)		
SITE COMPONENTS						3													
Site Components	Concrete Walks		2016	40	2056		5	4	2019	0%	0	2056	9,460	sf		\$5.00	\$47,300	\$486,179	
Site Components	Concrete Patios		2016	20	2036		5	4	2019	0%	0	2036	237	sf		\$18.00	\$4,270	\$12,455	
Site Components	Landscaping		2016	50	2066		5		2019	0%	0	2066	131,551	sf		\$0.20	\$26,310	\$507,640	
PLAY COMPONENTS																			
Play Component	Elevated Structures (2)		2016	15	2031		5	4	2019	0%	0	2031	2	each		\$25,000.00	\$50,000	\$106,455	See Accessibility Chart
Play Component	Ground Equipment		2016	15	2031		5	4	2019	0%	0	2031	8	each		\$2,500.00	\$20,000	\$42,582	See Accessibility Chart
Play Component	Mulch		2016	10	2026		5	1	2019	0%	0	2026	9,163	sf		\$5.00	\$45,815	\$71,196	
Play Component	Edge Restraint		2016	40	2056		5		2019	0%	0	2056	584	lf		\$38.00	\$22,192	\$228,103	Plastic Edging
PARK AMENITIES																			
Park Amenities	Benches		2016	10	2026		5	4	2019	20%	2	2028	2	each		\$1,000.00	\$2,000	\$3,525	
Park Amenities	Trash/Recycling		2016	10	2026		5	4	2019	20%	2	2028	2	each		\$400.00	\$800	\$1,410	
Park Amenities	Pavilion		2016	25	2041		5	4	2019	0%	0	2041	120	sf		\$100.00	\$12,000	\$47,959	
RECREATION COMPONENTS																			
						3.00	5.00	3.63									\$230,687	\$1,507,504	

NOTES

Evaluation of building conditions focused on the elements likely to be included in the budget for items expected to require replacement or renovation within the next 10 to 15 years. Equipment, materials, or assemblies that are nominal in cost are not included. This is therefore not a comprehensive list but does identify major expenses that are likely to be incurred in the foreseeable future.

Conditions change with time, and this evaluation, along with the funds allocated to cover the associated expenses should be reviewed and revised periodically as the Department's needs evolve. Unanticipated expenses can develop for a number of reasons including accelerated use or changes in use patterns, accident, or deferred general maintenance. Such reviews should include updating baseline costs and dates for the components or assemblies identified in this study.

Costs are calculated at 2019 levels and escalated at the following presumed annual rate of inflation:

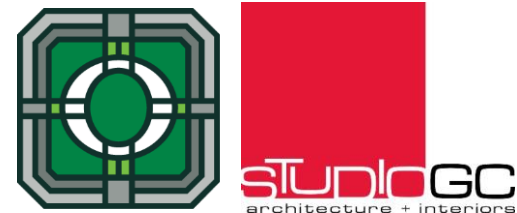
6.50% per annum

This report is broken up into different categories. The first three are organized by category with like expenses grouped together. The worksheets also covers Mechanical expenses, Electrical expenses, and Plumbing expenses. The last worksheet is organized by the computed year of expense (Budget Year).

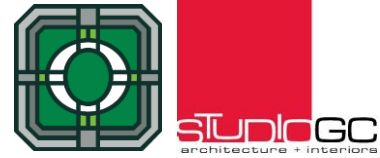
Repair/replacement work items do not include A/E Design Fees in the cost.

Total Combined Facilities

2026	\$71,196
2028	\$4,935
2031	\$149,037
2036	\$12,455
2041	\$47,959
2056	\$714,283
2066	\$507,640
Total:	\$1,507,504



NAME: HELEN PARK
ADDRESS: 9001 Helen Lane, Orland Park, IL 60462
PARK TYPE: Neighborhood
EVALUATION YEAR: 2019



PARK MAP:



PARK DATA:

Year Renovated:	1998
Park Age:	21
Total Acreage:	7.3
Total Parking Spaces:	0

Amenities:

Playground Equipment	Burke/Gametime
Baseball Field	Gravel
Basketball Court	Asphalt
Volleyball Court	Sand
Pavilion	
Picnic Grills	
Fishing	
Drinking Fountain	

SECURITY COMMENTS:

- Park security is as to be expected for this size facility. See a few specific areas of note:
- Baseball area and much of the open park is not visible from the road
 - Security lighting should be considered if law enforcement has concerns.
 - Landscaping should be trimmed to promote a reasonable amount of visibility from the road.

Score **3.00**

ACCESSIBILITY COMMENTS

- This park fairs well on accessibility.
- The mulch area is accessible with concrete ramps
 - There is a sidewalk to the basketball field, but note it does not extend to the baseball field.
 - There is a small amount of grass from the sidewalk which should be extended to the fields/courts to complete the accessibility.

Score **3.08**

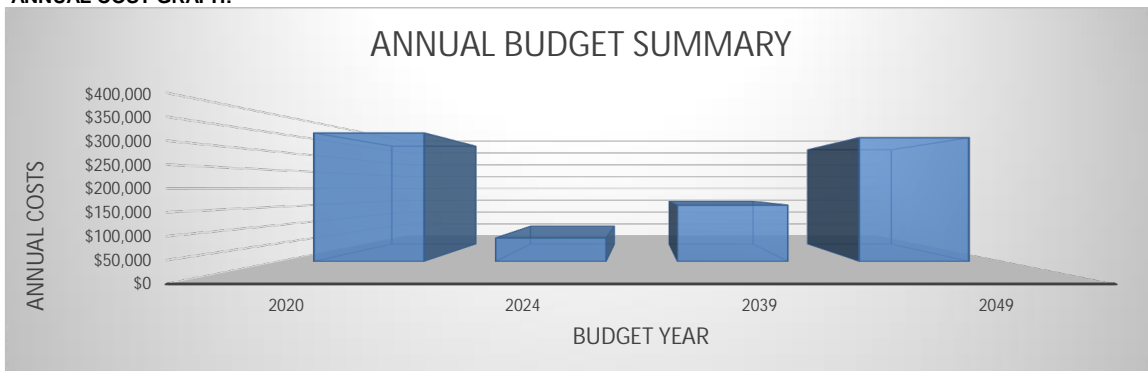
GENERAL CONDITION COMMENTS

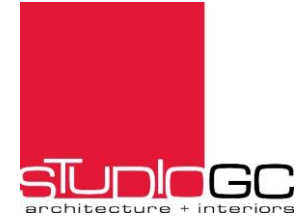
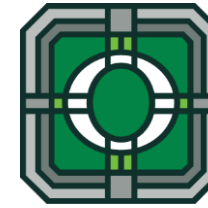
- The park is in exceptional condition given it's age. Much of the play equipment has aged well and has only minimal deterioration requiring spot repair.
- Site drainage should be re-evaluated. There are areas of standing water by the basketball court
 - The PIP is deteriorated due to it being installed on a slope. If this is not a play element then it should be regraded to allow for grass. Alternately a play slide could be added for an additional ground element
 - The fields/courts are nearing the end of their useful life and should be placed on an replacement schedule.

Score **2.79**

Score Average **2.96**

ANNUAL COST GRAPH:





COST BY BUDGET YEAR:

HELEN PARK

Budget Year	Component	Detail	Values	
			Sum of 2019 Replacement Cost	Sum of Escalated Budget
2020	SITE COMPONENTS	Concrete Patios	\$31,496.40	\$33,543.67
		PARK AMENITIES	Benches	\$5,000.00
		Trash/Recycling	\$800.00	\$852.00
		Drinking Fountain	\$6,500.00	\$6,922.50
	Play Component	Elevated Structures (2)	\$75,000.00	\$79,875.00
		Ground Equipment	\$5,000.00	\$5,325.00
		Mulch	\$41,701.00	\$44,411.57
	RECREATION COMPONENTS	Poured in Place	\$14,700.00	\$15,655.50
		Basketball Courts	\$115,000.00	\$122,475.00
		Sand Volleyball Court	\$35,000.00	\$37,275.00
2020 Total			\$330,197.40	\$351,660.23
2024	PARK AMENITIES	Picnic Grills	\$3,000.00	\$4,110.26
		Pavilion		\$44,060.00
2024 Total			\$47,060.00	\$64,476.28
2039	SITE COMPONENTS	Concrete Walks	\$27,513.55	\$96,947.98
	Play Component	Edge Restraint	\$16,226.00	\$57,174.66
2039 Total			\$43,739.55	\$154,122.65
2049	SITE COMPONENTS	Landscaping	\$16,204.30	\$107,181.17
	RECREATION COMPONENTS	Baseball Field	\$35,000.00	\$231,502.82
2049 Total			\$51,204.30	\$338,683.99

HELEN PARK		9001 Helen Lane, Orland Park, IL 60462				Assessment			Evaluated Condition			Estimated Cost Data - 2019						Comments	
Description/Life Expectancy		Task	Installed Date	Service Life	Anticipated Replacement Date	Security (1-5)	General (1-5)	Accessibility (1-5)	Evaluation Date	Life Expectancy Modifier	Life Expectancy Beyond Evaluation (years remaining)	Budget Year	Qty	Units	Prorate	Unit Cost	2019 Replacement Cost		Escalated Budget
Component	Detail		(year)	(years)	(year)	(0 is lowest)	(0 is lowest)	(0 is lowest)	(year)	%	(0 is lowest)						(As of Evaluation date)		
SITE COMPONENTS						3													
Site Components	Concrete Walks		1999	40	2039		3	5	2019	0%	0	2039.0	5,503	sf		\$5.00	\$27,514	\$96,948	
Site Components	Concrete Patios		1999	20	2019		3	5	2019	5%	1	2020.0	1,750	sf		\$18.00	\$31,496	\$33,544	
Site Components	Landscaping		1999	50	2049		2		2019	0%	0	2049.0	162,043	sf		\$0.10	\$16,204	\$107,181	
PLAY COMPONENTS																			
Play Component	Elevated Structures (2)		1999	15	2014		3	4	2019	40%	6	2020.0	3	each		\$25,000.00	\$75,000	\$79,875	See Accessibility Chart
Play Component	Ground Equipment		1999	15	2014		3	4	2019	40%	6	2020.0	2	each		\$2,500.00	\$5,000	\$5,325	See Accessibility Chart
Play Component	Mulch		2010	10	2020		3	5	2019	0%	0	2020.0	8,340	sf		\$5.00	\$41,701	\$44,412	
Play Component	Poured in Place		1999	10	2009		2	2	2019	110%	11	2020.0	350	sf		\$42.00	\$14,700	\$15,656	
Play Component	Edge Restraint		1999	40	2039		4		2019	0%	0	2039.0	427	lf		\$38.00	\$16,226	\$57,175	Plastic Edging
PARK AMENITIES																			
Park Amenities	Benches		1999	10	2009		3	1	2019	110%	11	2020.0	5	each		\$1,000.00	\$5,000	\$5,325	
Park Amenities	Trash/Recycling		1999	10	2009		3	3	2019	110%	11	2020.0	2	each		\$400.00	\$800	\$852	
Park Amenities	Pavilion		1999	25	2024		3	3	2019	0%	0	2024.0	441	sf		\$100.00	\$44,060	\$60,366	
Park Amenities	Drinking Fountain		1999	20	2019				2019	5%	1	2020.0	1	each		\$6,500.00	\$6,500	\$6,923	
Park Amenities	Picnic Grills		1999	15	2025				2019	-10%	-2	2024.0	1	each		\$3,000.00	\$3,000	\$4,110	
RECREATION COMPONENTS																			
Recreation Components	Basketball Courts		1999	20	2019		2	3	2019	5%	1	2020.0	1	each		\$115,000.00	\$115,000	\$122,475	
Recreation Components	Baseball Field		1999	50	2049		3	1	2019	0%	0	2049.0	1	each		\$35,000.00	\$35,000	\$231,503	
Recreation Components	Sand Volleyball Court		1999	20	2019		2	1	2019	5%	1	2020.0	1	each		\$35,000.00	\$35,000	\$37,275	
						3.00	2.79	3.08									\$437,201	\$871,668	

NOTES

Evaluation of building conditions focused on the elements likely to be included in the budget for items expected to require replacement or renovation within the next 10 to 15 years. Equipment, materials, or assemblies that are nominal in cost are not included. This is therefore not a comprehensive list but does identify major expenses that are likely to be incurred in the foreseeable future.

Conditions change with time, and this evaluation, along with the funds allocated to cover the associated expenses should be reviewed and revised periodically as the Department's needs evolve. Unanticipated expenses can develop for a number of reasons including accelerated use or changes in use patterns, accident, or deferred general maintenance. Such reviews should include updating baseline costs and dates for the components or assemblies identified in this study.

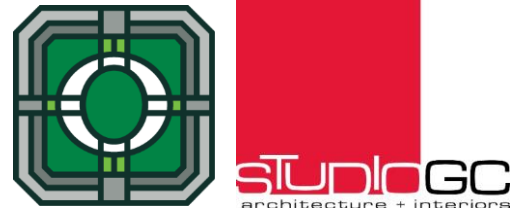
Costs are calculated at 2019 levels and escalated at the following presumed annual rate of inflation:

6.50% per annum

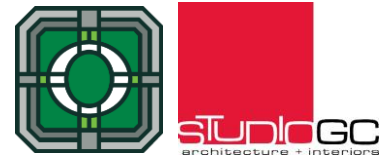
This report is broken up into different categories. The first three are organized by category with like expenses grouped together. The worksheets also covers Mechanical expenses, Electrical expenses, and Plumbing expenses. The last worksheet is organized by the computed year of expense (Budget Year).

Repair/replacement work items do not include A/E Design Fees in the cost.

Total Combined Facilities	
2020	\$351,660
2024	\$64,476
2039	\$154,123
2049	\$338,684
Total:	\$908,943



NAME: HERITAGE PARK
ADDRESS: 14039 Concord Dr, Orland Park
PARK TYPE: Neighborhood
EVALUATION YEAR: 2019



PARK MAP:



PARK DATA:

Year Renovated:	1995
Park Age:	24
Total Acreage:	4.1
Total Parking Spaces:	20

Amenities:

Playground Equip:	Landscape Struct
Baseball Field	
Basketball Court	2
Pavilion	
Picnic Grills	
Tennis Court	
Soccer Field	

SECURITY COMMENTS:

Score **3.00**

- Park security is as to be expected for this size facility. See a few specific areas of note and one concern:
- Great visibility from public ways
 - Security lighting should be considered if law enforcement has concerns.

ACCESSIBILITY COMMENTS

Score **1.57**

- The park was constructed before the 2010 Accessibility Code and is not compliant.
- The elevated structure is not accessible.
 - The entry to the play surface is too steep
 - There is no accessible route to the recreational areas.

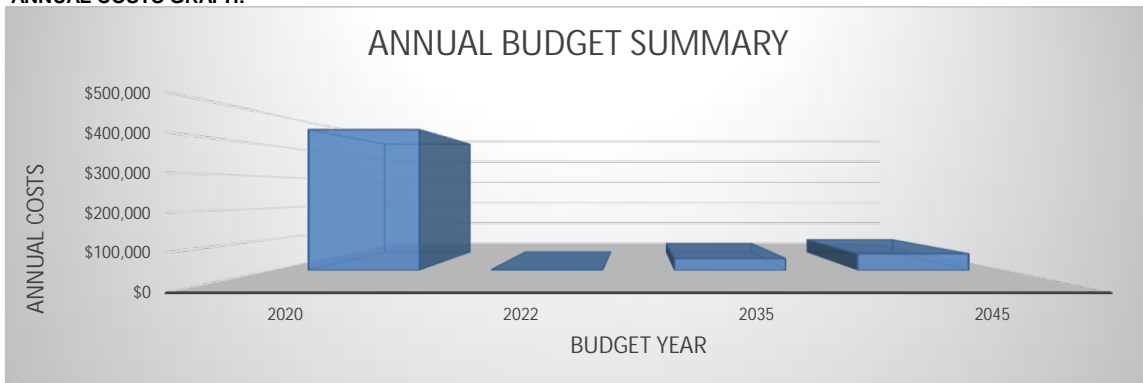
GENERAL CONDITION COMMENTS

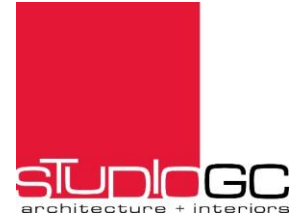
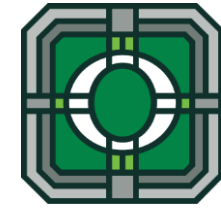
Score **2.40**

- The park is in good condition given the age. There are a few areas of concern:
- There is site drainage issues around the playground area
 - The basketball area has a drain hole in the area of play.
 - The tennis court is deteriorated and at the end of it's useful life. The paving has deteriorated and is trapping water.

Score Average **2.32**

ANNUAL COSTS GRAPH:





COST BY BUDGET YEAR:

HERITAGE PARK

Budget Year	Component	Detail	Values	
			Sum of Escalated Budget	Sum of 2019 Replacement Cost
2020	SITE COMPONENTS	Concrete Patios	\$9,776.70	\$9,180.00
		PARK AMENITIES	Benches	\$7,455.00
		Trash/Recycling	\$426.00	\$400.00
		Pavillion	\$17,998.50	\$16,900.00
	Play Component	Mulch	\$22,423.58	\$21,055.00
	RECREATION COMPONENTS	Basketball Courts	\$244,950.00	\$230,000.00
		Tennis Court	\$143,775.00	\$135,000.00
		Fencing	\$23,515.20	\$22,080.00
		Soccer Goal Post	\$10,650.00	\$10,000.00
2020 Total			\$480,969.98	\$451,615.00
2022	SITE COMPONENTS	Parking Spaces/Lot (10+1HC)	\$2,415.90	\$2,000.00
2022 Total			\$2,415.90	\$2,000.00
2035	SITE COMPONENTS	Concrete Walks	\$102,644.42	\$37,475.00
2035 Total			\$102,644.42	\$37,475.00
2045	SITE COMPONENTS	Landscaping	\$91,825.13	\$17,859.60
	RECREATION COMPONENTS	Baseball Field	\$179,952.48	\$35,000.00
2045 Total			\$271,777.61	\$52,859.60
Grand Total			\$857,807.91	\$543,949.60

HERITAGE PARK 14039 Concord Dr, Orland Park																			
Description/Life Expectancy						General Conditions			Evaluated Condition			Estimated Cost Data - 2019						Comments	
Component	Detail	Task	Installed Date	Service Life	Anticipated Replacement Date	Security (1-5)	General (1-5)	Accessibility (1-5)	Evaluation Date	Life Expectancy Modifier	Life Expectancy Beyond Evaluation (years remaining)	Budget Year	Qty	Units	Prorate	Unit Cost	2019 Replacement Cost		Escalated Budget
			(year)	(years)	(year)	(0 is lowest)	(0 is lowest)	(0 is lowest)	(year)	%	(0 is lowest)						(As of Evaluation date)		
SITE COMPONENTS						3													
Site Components	Asphalt - Sealcoat		2017	2	2019		3		2019	30%	1	2020	4,818	sf		\$1.00	\$4,818	\$5,004	
Site Components	Asphalt Replacement		1995	15	2010		3		2019	65%	10	2020	4,818	sf		\$7.00	\$33,726	\$35,357	
Site Components	Concrete Walks		1995	40	2035		4	2	2019	0%	0	2035	7,495	sf		\$5.00	\$37,475	\$102,644	
Site Components	Concrete Patios		1995	20	2015		2	3	2019	25%	5	2020	510	sf		\$18.00	\$9,180	\$9,777	
Site Components	Landscaping		1995	50	2045		3		2019	0%	0	2045	178,596	sf		\$0.10	\$17,860	\$91,825	
Site Components	Parking Spaces/Lot (10+1HC)		2017	5	2022				2019	0%	0	2022	20	each		\$100.00	\$2,000	\$2,416	
PLAY COMPONENTS																			
Play Component	Elevated Structures (2)		1995	15	2010		2	1	2019	65%	10	2020	3	each		\$25,000.00	\$75,000	\$78,627	
Play Component	Ground Equipment		1995	15	2010		2		2019	65%	10	2020	4	each		\$3,500.00	\$14,000	\$14,677	
Play Component	Mulch		2010	10	2020		2	2	2019	0%	0	2020	4,211	sf		\$5.00	\$21,055	\$22,424	
Play Component	Edge Restraint		1995	40	2035		1		2019	-38%	-15	2020	281	lf		\$38.00	\$10,678	\$11,230	
PARK AMENITIES																			
Park Amenities	Benches		1995	10	2005		2		2019	150%	15	2020	7	each		\$1,000.00	\$7,000	\$7,455	
Park Amenities	Trash/Recycling		1995	10	2005		2		2019	150%	15	2020	1	each		\$400.00	\$400	\$426	
Park Amenities	Pavillion		1995	25	2020		2		2019	0%	0	2020	169	sf		\$100.00	\$16,900	\$17,999	
Park Amenities	Picnic Grills																		
RECREATION COMPONENTS																			
Recreation Components	Basketball Courts		1995	20	2015		2	1	2019	25%	5	2020	2.0	each		\$115,000.00	\$230,000	\$244,950	
Recreation Components	Baseball Field		1995	50	2045		3	1	2019	0%	0	2045	1	each		\$35,000.00	\$35,000	\$179,952	
Recreation Components	Tennis Court		1995	20	2015		3	1	2019	25%	5	2020	1	each		\$135,000.00	\$135,000	\$143,775	
Recreation Components	Fencing		1995	10	2005				2019	150%	15	2020	276	lf		\$80.00	\$22,080	\$23,515	
Recreation Components	Soccer Goal Post		1995	5	2000				2019	400%	20	2020	2	each		\$5,000.00	\$10,000	\$10,650	
						3.00	2.40	1.57									\$650,092	\$968,538	

NOTES

Evaluation of building conditions focused on the elements likely to be included in the budget for items expected to require replacement or renovation within the next 10 to 15 years. Equipment, materials, or assemblies that are nominal in cost are not included. This is therefore not a comprehensive list but does identify major expenses that are likely to be incurred in the foreseeable future.

Conditions change with time, and this evaluation, along with the funds allocated to cover the associated expenses should be reviewed and revised periodically as the Department's needs evolve. Unanticipated expenses can develop for a number of reasons including accelerated use or changes in use patterns, accident, or deferred general maintenance. Such reviews should include updating baseline costs and dates for the components or assemblies identified in this study.

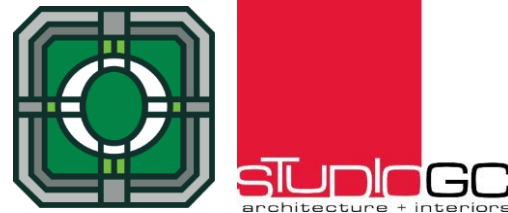
Costs are calculated at 2019 levels and escalated at the following presumed annual rate of inflation:

6.50% per annum

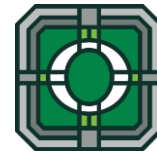
This report is broken up into different categories. The first three are organized by category with like expenses grouped together. The worksheets also covers Mechanical expenses, Electrical expenses, and Plumbing expenses. The last worksheet is organized by the computed year of expense (Budget Year).

Repair/replacement work items do not include A/E Design Fees in the cost.

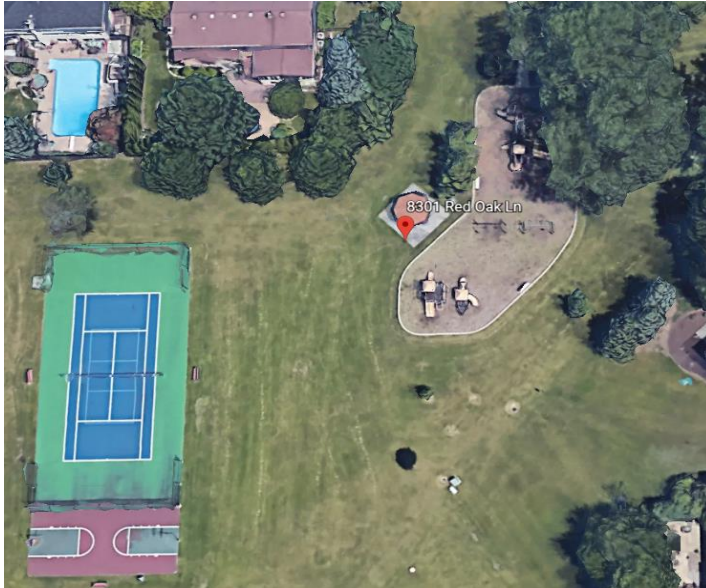
Total Combined Facilities	
2020	\$451,615
2022	\$2,000
2035	\$37,475
2045	\$52,860
Total:	\$543,950



NAME: ISHNALA PARK
ADDRESS: 8301 Red Oak Lawn, Orland Park
PARK TYPE: Neighborhood
EVALUATION YEAR: 2019



PARK MAP:



PARK DATA:

Year Renovated:	1995
Park Age:	24
Total Acreage:	3.4
Total Parking Spaces:	0

Amenities:

Playground Equip:	Iron Mountain Forge
Basketball Court	1
Handicap Swing	
Horseshoes	
Pavilion	
Pickleball	
Tennis Court	1

SECURITY COMMENTS:

Score **2.50**

- Park security is as to be expected for this size facility. See a few specific areas of note and one concern:
- Minimal visibility from public ways, the basketball and tennis courts are not visible from the public way.
 - Security lighting should be considered if law enforcement has concerns.
 - Trimming the landscape and shrubs would help immensely.

ACCESSIBILITY COMMENTS

Score **2.13**

- The park was constructed prior to the 2010 Accessibility Code. Therefore there are a few items of note:
- The play area is not accessible via a ramp into the fiber surfacing.
 - The play equipment has transfer stations but a full assessment should be completed.
 - The courts are not on an accessible path.

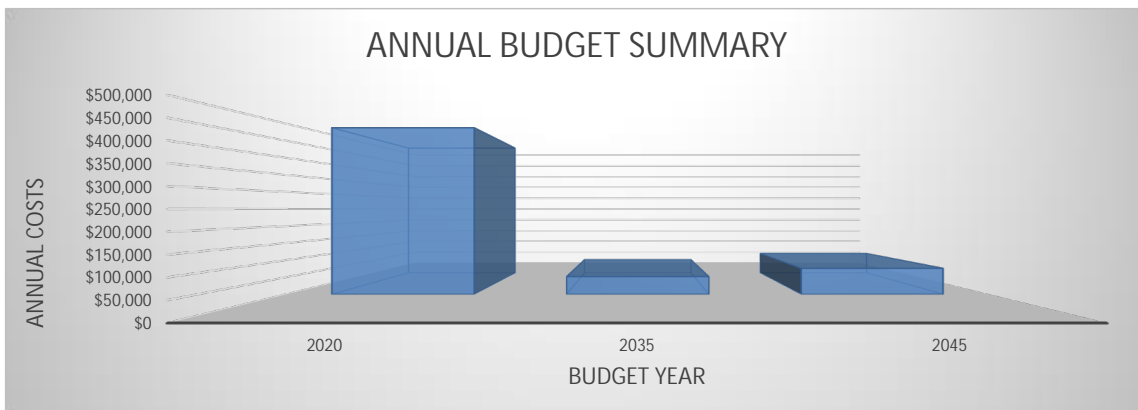
GENERAL CONDITION COMMENTS

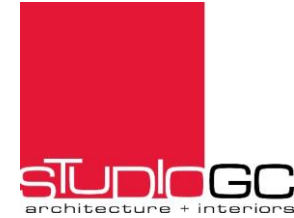
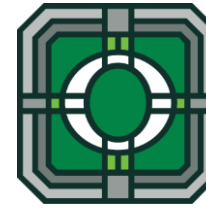
Score **2.42**

- The park is in good condition for it's age.
- The recreational amenities are at the end of their useful life and the play equipment has surface deterioration and lichen from lack of sunlight.
 - Sidewalks are aging faster than expected.
 - Flooding by pavilion
 - Pavilion is to small

Score Average **2.35**

ANNUAL COST GRAPH:





COST BY BUDGET YEAR:

ISHNALA PARK

Budget Year	Component	Detail	Values	
			Sum of 2019 Replacement Cost	Sum of Escalated Budget
2020	SITE COMPONENTS	Concrete Patios	\$9,972.00	\$10,620.18
		PARK AMENITIES	Benches	\$7,000.00
		Pavilion	\$35,000.00	\$37,275.00
		Trash/Recycling	\$1,200.00	\$1,278.00
	Play Component	Elevated Structures (2)	\$100,000.00	\$106,500.00
		Ground Equipment	\$12,500.00	\$13,312.50
		Mulch	\$29,495.00	\$31,412.18
		Edge Restraint	\$12,806.00	\$13,638.39
	RECREATION COMPON	Basketball Courts	\$115,000.00	\$122,475.00
		Tennis Court	\$135,000.00	\$143,775.00
2020 Total			\$457,973.00	\$487,741.25
2035	SITE COMPONENTS	Concrete Walks	\$18,950.00	\$51,904.25
2035 Total			\$18,950.00	\$51,904.25
2045	SITE COMPONENTS	Landscaping	\$14,810.40	\$76,147.66
2045 Total			\$14,810.40	\$76,147.66
Grand Total			\$491,733.40	\$615,793.16

Description/Life Expectancy						Assessments			Evaluated Condition			Estimated Cost Data - 2019						Comments	
Component	Detail	Task	Installed Date	Service Life	Anticipated Replacement Date	Security (1-5)	General (1-5)	Accessibility (1-5)	Evaluation Date	Life Expectancy Modifier	Life Expectancy Beyond Evaluation (years remaining)	Budget Year	Qty	Units	Prorate	Unit Cost	2019 Replacement Cost		Escalated Budget
			(year)	(years)	(year)	(0 is lowest)	(0 is lowest)	(0 is lowest)	(year)	%	(0 is lowest)						(As of Evaluation date)		
SITE COMPONENTS						3													
Site Components	Concrete Walks		1995	40	2035		2	3	2019	0%	0	2035	3,790	sf		\$5.00	\$18,950	\$51,904	
Site Components	Concrete Patios		1995	20	2015		2		2019	25%	5	2020	554	sf		\$18.00	\$9,972	\$10,620	
Site Components	Landscaping		1995	50	2045		2		2019	0%	0	2045	148,104	sf		\$0.10	\$14,810	\$76,148	
PLAY COMPONENTS																			
Play Component	Elevated Structures (2)		1995	15	2010		2	3	2019	65%	10	2020	4	each		\$25,000.00	\$100,000	\$106,500	See Accessibility Chart
Play Component	Ground Equipment		1995	15	2010		2	3	2019	65%	10	2020	5	each		\$2,500.00	\$12,500	\$13,313	See Accessibility Chart
Play Component	Mulch		2010	10	2020		2	1	2019	0%	0	2020	5,899	sf		\$5.00	\$29,495	\$31,412	
Play Component	Edge Restraint		1995	40	2035		4		2019	-37%	-15	2020	337	lf		\$38.00	\$12,806	\$13,638	Plastic Edging
PARK AMENITIES																			
Park Amenities	Benches		1995	10	2005		3	2	2019	150%	15	2020	7	each		\$1,000.00	\$7,000	\$7,455	
Park Amenities	Trash/Recycling		1995	10	2005		3		2019	150%	15	2020	3	each		\$400.00	\$1,200	\$1,278	
Park Amenities	Pavilion		1995	25	2020		3	3	2019	0%	0	2020	350	sf		\$100.00	\$35,000	\$37,275	
RECREATION COMPONENTS						2													
Recreation Components	Basketball Courts		1995	20	2015		2	1	2019	25%	5	2020	1	each		\$115,000.00	\$115,000	\$122,475	
Recreation Components	Tennis Court		1995	20	2015		2	1	2019	25%	5	2020	1	each		\$135,000.00	\$135,000	\$143,775	
						2.50	2.42	2.13									\$491,733	\$615,793	

NOTES

Evaluation of building conditions focused on the elements likely to be included in the budget for items expected to require replacement or renovation within the next 10 to 15 years. Equipment, materials, or assemblies that are nominal in cost are not included. This is therefore not a comprehensive list but does identify major expenses that are likely to be incurred in the foreseeable future.

Conditions change with time, and this evaluation, along with the funds allocated to cover the associated expenses should be reviewed and revised periodically as the department's needs evolve. Unanticipated expenses can develop for a number of reasons including accelerated use or changes in use patterns, accident, or deferred general maintenance. Such reviews should include updating baseline costs and dates for the components or assemblies identified in this study.

Costs are calculated at 2019 levels and escalated at the following presumed annual rate of inflation:

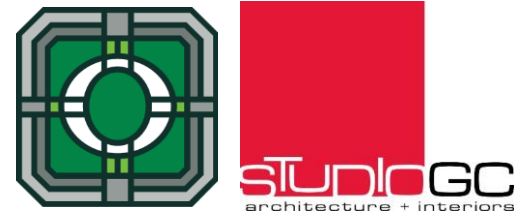
6.50% per annum

This report is broken up into different categories. The first three are organized by category with like expenses grouped together. The worksheets also covers Mechanical expenses, Electrical expenses, and Plumbing expenses. The last worksheet is organized by the computed year of expense (Budget Year).

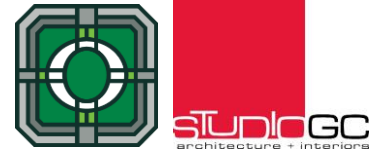
Repair/replacement work items do not include A/E Design Fees in the cost.

Total Combined Facilities

2020	\$487,741
2035	\$51,904
2045	\$76,148
Total:	\$615,793



NAME: ISHNALA WOODS PARK
ADDRESS: 13600 80th Avenue, Orland Park
PARK TYPE: Neighborhood
EVALUATION YEAR: 2019



PARK MAP:



PARK DATA:

Year Renovated:	1998
Park Age:	21
Total Acreage:	6
Total Parking Spaces:	0

Amenities:

- Playground Equip: Little Tykes
- Baseball
- Basketball Court
- Bike/ Walking Path
- Drinking Fountain
- Handicap Swing
- Pavilion
- Soccer Field

SECURITY COMMENTS:

Score 3.00

- Park security is as to be expected for this size facility. See a few specific areas of note and one concern:
- Great visibility from public ways
 - Security lighting should be considered if law enforcement has concerns.

ACCESSIBILITY COMMENTS

Score 1.56

- The playground equipment was constructed prior to the 2010 Accessibility Code revision. There are some areas of concern:
- The pavilion is not on an accessible path.
 - A study should be started to determine compliance.
 - The recreational fields and courts are not on an accessible path
 - The ramp access to the fiber play area is not compliant

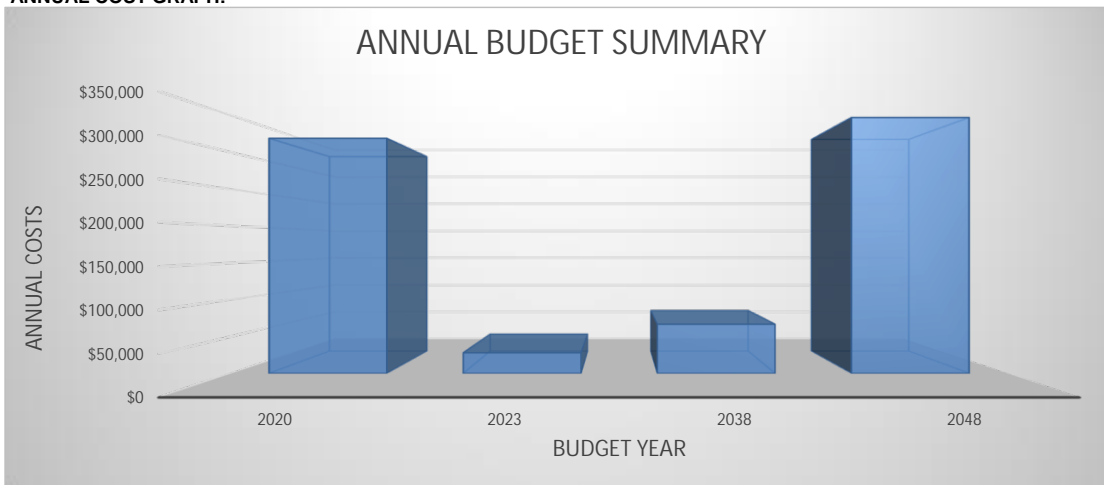
GENERAL CONDITION COMMENTS

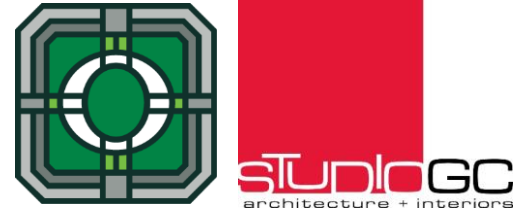
Score 2.07

- Park is significantly deteriorated. Some components are in acceptable condition which is unduly swaying the score.
- Asphalt walks are severely deteriorated.
 - Playing fields are deteriorated and verging on unsafe conditions with fencing at sport areas.
 - Flooding and fiber washout indicating drainage and grading issues

Score Average 2.21

ANNUAL COST GRAPH:





COST BY BUDGET YEAR:

MARLEY PARK

Budget Year	Component	Detail	Values	
			Sum of 2019 Replacement Cost	Sum of Escalated Budget
2020	SITE COMPONENTS	Concrete Patios	\$9,648.00	\$10,275.12
		Walkways	\$9,036.00	\$9,623.34
	PARK AMENITIES	Benches	\$5,000.00	\$5,325.00
		Trash/Recycling	\$400.00	\$426.00
	Play Component	Elevated Structures (2)	\$75,000.00	\$79,875.00
		Ground Equipment	\$9,600.00	\$10,224.00
		Mulch	\$37,255.00	\$39,676.58
	RECREATION COMPONENTS	Basketball Courts	\$115,000.00	\$122,475.00
		Soccer Goals (practice)	\$5,000.00	\$5,325.00
		Fencing	\$33,600.00	\$35,784.00
2020 Total			\$299,539.00	\$319,009.04
2023	PARK AMENITIES	Pavilion	\$21,800.00	\$28,044.97
2023 Total			\$21,800.00	\$28,044.97
2038	Play Component	Edge Restraint	\$20,178.00	\$66,760.67
2038 Total			\$20,178.00	\$66,760.67
2048	SITE COMPONENTS	Landscaping	\$20,908.80	\$129,857.71
	RECREATION COMPONENTS	Baseball Field	\$35,000.00	\$217,373.54
2048 Total			\$55,908.80	\$347,231.24

ISHNALA WOODS PARK		13600 80th Avenue, Orland Park				Assessments			Evaluated Condition			Estimated Cost Data - 2019						Comments	
Description/Life Expectancy		Task	Installed Date	Service Life	Anticipated Replacement Date	Security (1-5)	General (1-5)	Accessibility (1-5)	Evaluation Date	Life Expectancy Modifier	Life Expectancy Beyond Evaluation (years remaining)	Budget Year	Qty	Units	Prorate	Unit Cost	2019 Replacement Cost		Escalated Budget
Component	Detail		(year)	(years)	(year)	(0 is lowest)	(0 is lowest)	(0 is lowest)	(year)	%	(0 is lowest)						(As of Evaluation date)		
SITE COMPONENTS						3													
Site Components	Walkways		1998	20	2018		1	2	2019	10%	2	2020	502	sf		\$18.00	\$9,036	\$9,623	
Site Components	Landscaping		1998	50	2048		3		2019	0%	0	2048	261,360	sf		\$0.08	\$20,909	\$129,858	
Site Components	Concrete Patios		1998	20	2018		1	1	2019	12%	2	2020	536	sf		\$18.00	\$9,648	\$10,275	
PLAY COMPONENTS																			
Play Component	Elevated Structures (2)		1998	15	2013		2	2	2019	48%	7	2020	3	each		\$25,000.00	\$75,000	\$79,875	
Play Component	Ground Equipment		1998	15	2013		1		2019	48%	7	2020	8	each		\$1,200.00	\$9,600	\$10,224	
Play Component	Mulch		2010	10	2020		3	1	2019	0%	0	2020	7,451	sf		\$5.00	\$37,255	\$39,677	
Play Component	Edge Restraint		1998	40	2038		3		2019	0%	0	2038	531	lf		\$38.00	\$20,178	\$66,761	
PARK AMENITIES																			
Park Amenities	Benches		1998	10	2008		3	2	2019	120%	12	2020	5	each		\$1,000.00	\$5,000	\$5,325	
Park Amenities	Trash/Recycling		1998	10	2008		3	1	2019	120%	12	2020	1	each		\$400.00	\$400	\$426	
Park Amenities	Pavilion		1998	25	2023		2	2	2019	0%	0	2023	218	sf		\$100.00	\$21,800	\$28,045	
Park Amenities	Drinking Fountains		1998	15	2013		2		2019	33%	5	2018	1	each		\$6,500.00	\$3,000	\$2,817	
RECREATION COMPONENTS																			
Recreation Components	Basketball Courts		1998	20	2018		2	2	2019	10%	2	2020	1.0	each		\$115,000.00	\$115,000	\$122,475	
Recreation Components	Baseball Field		1998	50	2048		1	1	2019	0%	0	2048	1.0	each		\$35,000.00	\$35,000	\$217,374	
Recreation Components	Soccer Goals (practice)		1998	5	2003		2		2019	340%	17	2020	1	each		\$5,000.00	\$5,000	\$5,325	
Recreation Components	Fencing		1998	10	2008				2019	120%	12	2020	168	lf		\$200.00	\$33,600	\$35,784	
						3.00	2.07	1.56							\$361,826	\$722,754			

NOTES

Evaluation of building conditions focused on the elements likely to be included in the budget for items expected to require replacement or renovation within the next 10 to 15 years. Equipment, materials, or assemblies that are nominal in cost are not included. This is therefore not a comprehensive list but does identify major expenses that are likely to be incurred in the foreseeable future.

Conditions change with time, and this evaluation, along with the funds allocated to cover the associated expenses should be reviewed and revised periodically as the Department's needs evolve. Unanticipated expenses can develop for a number of reasons including accelerated use or changes in use patterns, accident, or deferred general maintenance. Such reviews should include updating baseline costs and dates for the components or assemblies identified in this study.

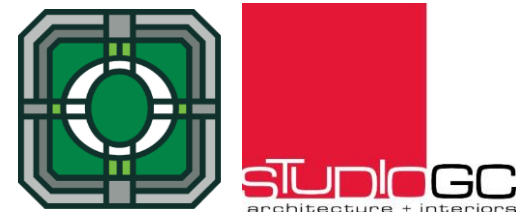
Costs are calculated at 2019 levels and escalated at the following presumed annual rate of inflation:

6.50% per annum

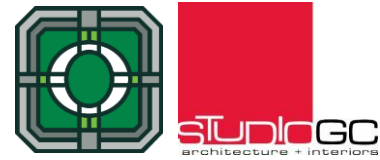
This report is broken up into different categories. The first three are organized by category with like expenses grouped together. The worksheets also covers Mechanical expenses, Electrical expenses, and Plumbing expenses. The last worksheet is organized by the computed year of expense (Budget Year).

Repair/replacement work items do not include A/E Design Fees in the cost.

Total Combined Facilities	
2020	\$319,009
2023	\$28,045
2038	\$66,761
2048	\$347,231
Total:	\$761,046



NAME: LAUREL HILL PARK
ADDRESS: 11001 Laurel Hill Drive, Orland Park
PARK TYPE: Neighborhood
EVALUATION YEAR: 2019



PARK MAP:



PARK DATA:

Year Renovated:	1996
Park Age:	23
Total Acreage:	10
Total Parking Spaces:	0

Amenities:

Playground Equipment	Landscape Struct.
Basketball Court	2
Handicap Swing	
Tennis Court	1

SECURITY COMMENTS:

Score **3.00**

Park security is as to be expected for this size facility. See a few specific areas of note and one concern:

- Great visibility from public ways
- Security lighting should be considered if law enforcement has concerns.

ACCESSIBILITY COMMENTS

Score **2.57**

The park was created prior to the accessibility code update of 2010. A full accessibility review should be conducted.

- Play area ramps are not accessible.

GENERAL CONDITION COMMENTS

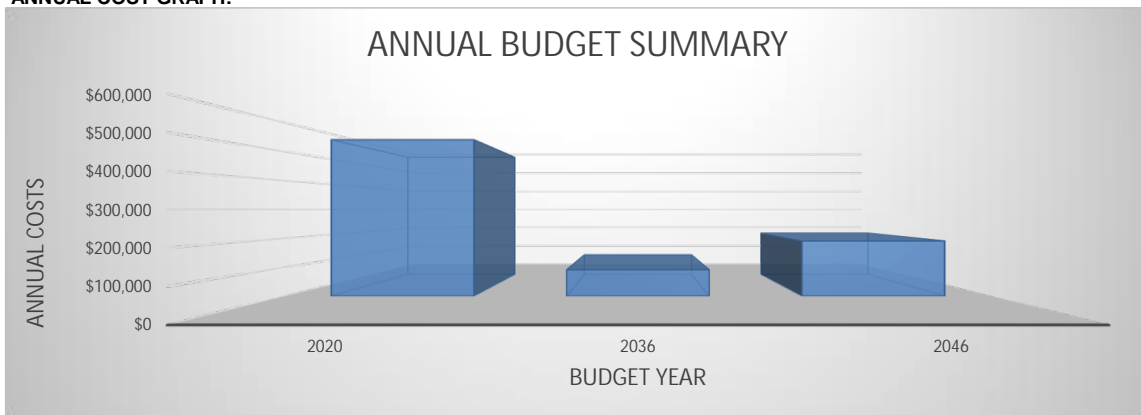
Score **2.91**

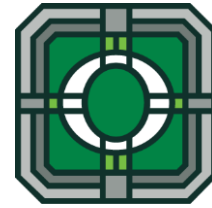
The park is in remarkable condition given it's age.

- All deterioration is cosmetic.
- Sand play area should be re-evaluated.
- Tennis court is in great shape.
- Concrete block retaining blocks should be reviewed for safety, many parks have loose caps and blocks.

Score Average **2.83**

ANNUAL COST GRAPH:





COST BY BUDGET YEAR:

LAUREL HILL PARK

Budget Year	Component	Detail	Values	
			Sum of 2019 Replacement Cost	Sum of Escalated Budget
2020	SITE COMPONENTS	Concrete Patios	\$19,710.00	\$20,991.15
		PARK AMENITIES	Benches	\$5,000.00
		Trash/Recycling	\$800.00	\$852.00
	Play Component	Elevated Structures (2)	\$75,000.00	\$79,875.00
		Ground Equipment	\$10,000.00	\$10,650.00
		Mulch	\$32,670.00	\$34,793.55
	RECREATION COMPON	Tennis Court	\$135,000.00	\$143,775.00
		Basketball Courts	\$230,000.00	\$244,950.00
2020 Total			\$508,180.00	\$541,211.70
2036	SITE COMPONENTS	Concrete Walks	\$12,075.00	\$35,223.33
	Play Component	Edge Restraint	\$19,114.00	\$55,756.42
2036 Total			\$31,189.00	\$90,979.76
2046	SITE COMPONENTS	Landscaping	\$34,848.00	\$190,817.09
2046 Total			\$34,848.00	\$190,817.09
Grand Total			\$574,217.00	\$823,008.55

Description/Life Expectancy						Assessments			Evaluated Condition			Estimated Cost Data - 2019						Comments	
Component	Detail	Task	Installed Date	Service Life	Anticipated Replacement Date	Security (1-5)	General (1-5)	Accessibility (1-5)	Evaluation Date	Life Expectancy Modifier	Life Expectancy Beyond Evaluation (years remaining)	Budget Year	Qty	Units	Prorate	Unit Cost	2019 Replacement Cost		Escalated Budget
			(year)	(years)	(year)	(0 is lowest)	(0 is lowest)	(0 is lowest)	(year)	%	(0 is lowest)						(As of Evaluation date)		
SITE COMPONENTS						3													
Site Components	Concrete Walks		1996	40	2036		4		2019	0%	0	2036	2,415	sf		\$5.00	\$12,075	\$35,223	
Site Components	Concrete Patios		1996	20	2016		4	3	2019	20%	4	2020	1,095	sf		\$18.00	\$19,710	\$20,991	
Site Components	Landscaping		1996	50	2046				2019	0%	0	2046	435,600	sf		\$0.08	\$34,848	\$190,817	
PLAY COMPONENTS						3													
Play Component	Elevated Structures (2)		1996	15	2011		2	3	2019	60%	9	2020	3	each		\$25,000.00	\$75,000	\$79,875	See Accessibility Chart
Play Component	Ground Equipment		1996	15	2011		3		2019	60%	9	2020	4	each		\$2,500.00	\$10,000	\$10,650	See Accessibility Chart
Play Component	Mulch		2010	10	2020		3	2	2019	0%	0	2020	6,534	sf		\$5.00	\$32,670	\$34,794	
Play Component	Sand Play Areas		1996	10	2006		2	1	2019	135%	14	2020	300	sf		\$5.00	\$1,500	\$1,548	
Play Component	Edge Restraint		1996	40	2036		4		2019	0%	0	2036	503	lf		\$38.00	\$19,114	\$55,756	Plastic Edging
PARK AMENITIES						3													
Park Amenities	Benches		1996	10	2006		2	3	2019	140%	14	2020	5	each		\$1,000.00	\$5,000	\$5,325	
Park Amenities	Trash/Recycling		1996	10	2006		2		2019	140%	14	2020	2	each		\$400.00	\$800	\$852	
RECREATION COMPONENTS						3													
Recreation Components	Tennis Court		1996	20	2016		3	3	2019	20%	4	2020	1	each		\$135,000.00	\$135,000	\$143,775	
Recreation Components	Basketball Courts		1996	20	2016		3	3	2019	20%	4	2020	2.0	each		\$115,000.00	\$230,000	\$244,950	

NOTES

Evaluation of building conditions focused on the elements likely to be included in the budget for items expected to require replacement or renovation within the next 10 to 15 years. Equipment, materials, or assemblies that are nominal in cost are not included. This is therefore not a comprehensive list but does identify major expenses that are likely to be incurred in the foreseeable future.

Conditions change with time, and this evaluation, along with the funds allocated to cover the associated expenses should be reviewed and revised periodically as the Department's needs evolve. Unanticipated expenses can develop for a number of reasons including accelerated use or changes in use patterns, accident, or deferred general maintenance. Such reviews should include updating baseline costs and dates for the components or assemblies identified in this study.

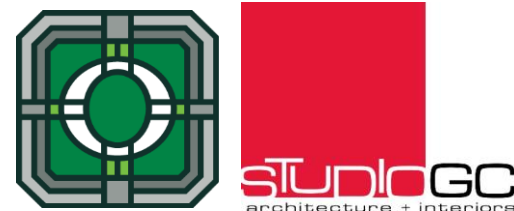
Costs are calculated at 2019 levels and escalated at the following presumed annual rate of inflation:

6.50% per annum

This report is broken up into different categories. The first three are organized by category with like expenses grouped together. The worksheets also covers Mechanical expenses, Electrical expenses, and Plumbing expenses. The last worksheet is organized by the computed year of expense (Budget Year).

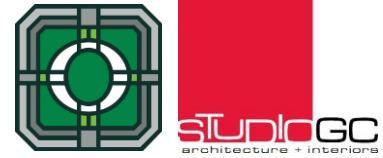
Repair/replacement work items do not include A/E Design Fees in the cost.

Total Combined Facilities	
2020	\$541,212
2036	\$90,980
2046	\$190,817
Total:	\$823,009



NOTES

NAME: LONG RUN CREEK PARK
ADDRESS: 11700 Long Run Drive, Orland Park
PARK TYPE: Neighborhood
EVALUATION YEAR: 2019



PARK MAP:



PARK DATA:

Year Renovated:	2004
Park Age:	15
Total Acreage:	6.7
Total Parking Spaces:	0

Amenities:

- Playground Equip: Gametime
- Basketball Court
- Bike/ Walking Path
- Drinking Fountain
- Pavilion
- Picnic Grills

SECURITY COMMENTS:

Score **2.00**

- The park has some safety and security concerns. A few specific areas of note and one concern:
- Poor visibility from public ways
 - Security lighting should be considered if law enforcement has concerns.

ACCESSIBILITY COMMENTS

Score **2.38**

- The park was constructed prior to the 2010 Accessibility Code revision.
- The only initial concern is the ramp to the play surface is not compliant.
 - Sand play area is not compliant.

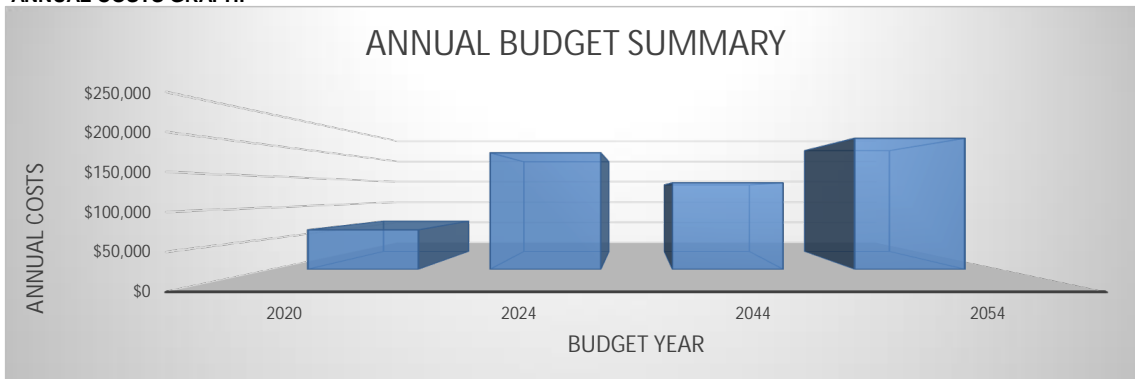
GENERAL CONDITION COMMENTS

Score **2.92**

- The park is aging a bit faster than one would anticipate.
- Most of the deterioration is cosmetic but should be routinely reviewed.
 - Basketball court is in good shape but the hoop could be replaced.
 - General park fixtures are not in keeping with current, modern standards.
 - Flooding washing out fiber indicating drainage and grading issues.

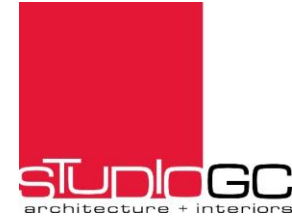
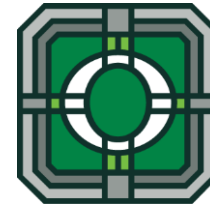
Score Average **2.43**

ANNUAL COSTS GRAPH:



COST BY BUDGET YEAR:

#REF!



Budget Year	Component	Detail	Values	
			Sum of 2019 Replacement Cost	Sum of Escalated Budget
2020	PARK AMENITIES	Benches	\$6,000.00	\$6,390.00
		Trash/Recycling	\$400.00	\$426.00
	Play Component	Mulch	\$30,025.00	\$31,976.63
		Sand Play Area	\$23,500.00	\$25,027.50
2020 Total			\$59,925.00	\$63,820.13
2024	SITE COMPONENTS	Concrete Patios	\$22,356.00	\$30,629.66
	RECREATION COMPONENTS	Basketball Courts	\$115,000.00	\$157,559.97
2024 Total			\$137,356.00	\$188,189.62
2044	SITE COMPONENTS	Concrete Walks	\$12,300.00	\$59,380.70
	Play Component	Edge Restraint	\$16,644.00	\$80,352.22
2044 Total			\$28,944.00	\$139,732.92
2054	SITE COMPONENTS	Landscaping	\$23,348.16	\$211,586.98
2054 Total			\$23,348.16	\$211,586.98
Grand Total			\$249,573.16	\$603,329.65

Description/Life Expectancy						Assessments			Evaluated Condition			Estimated Cost Data - 2019						Comments	
Component	Detail	Task	Installed Date	Service Life	Anticipated Replacement Date	Security (1-5)	General (1-5)	Accessibility (1-5)	Evaluation Date	Life Expectancy Modifier	Life Expectancy Beyond Evaluation (years remaining)	Budget Year	Qty	Units	Prorate	Unit Cost	2019 Replacement Cost		Escalated Budget
			(year)	(years)	(year)	(0 is lowest)	(0 is lowest)	(0 is lowest)	(year)	%	(0 is lowest)						(As of Evaluation date)		
SITE COMPONENTS						2													
Site Components	Concrete Walks		2004	40	2044		3	3	2019	0%	0	2044	2,460	sf		\$5.00	\$12,300	\$59,381	
Site Components	Concrete Patios		2004	20	2024		3	3	2019	0%	0	2024	1,242	sf		\$18.00	\$22,356	\$30,630	
Site Components	Landscaping		2004	50	2054				2019	0%	0	2054	291,852	sf		\$0.08	\$23,348	\$211,587	
PLAY COMPONENTS						2													
Play Component	Elevated Structures (2)		2004	15	2019		2	2	2019	8%	1	2020	4	each		\$25,000.00	\$100,000	\$107,850	See Accessibility Chart
Play Component	Ground Equipment		2004	15	2019		2	2	2019	8%	1	2020	7	each		\$2,500.00	\$17,500	\$18,874	See Accessibility Chart
Play Component	Mulch		2004	10	2014		3	2	2019	60%	6	2020	6,005	sf		\$5.00	\$30,025	\$31,977	
Play Component	Sand Play Area		2004	10	2014		2	1	2019	60%	6	2020	500	sf		\$47.00	\$23,500	\$25,028	
Play Component	Edge Restraint		2004	40	2044		5		2019	0%	0	2044	438	lf		\$38.00	\$16,644	\$80,352	Plastic Edging
PARK AMENITIES						2													
Park Amenities	Benches		2004	10	2014		3	3	2019	60%	6	2020	6	each		\$1,000.00	\$6,000	\$6,390	
Park Amenities	Trash/Recycling		2004	10	2014		3		2019	60%	6	2020	1	each		\$400.00	\$400	\$426	
Park Amenities	Drinking Fountains		2004	15	2019		3		2019	8%	1	2020	1	each		\$3,000.00	\$3,000	\$3,235	
Park Amenities	Picnic Grills		2004	15	2019		3		2019	0%	0	2019	1	each		\$1,500.00	\$1,500	\$1,500	
RECREATION COMPONENTS						2													
Recreation Components	Basketball Courts		2004	20	2024		3	3	2019	0%	0	2024	1.0	each		\$115,000.00	\$115,000	\$157,560	
						2.00	2.92	2.38									\$371,573	\$734,789	

NOTES

Evaluation of building conditions focused on the elements likely to be included in the budget for items expected to require replacement or renovation within the next 10 to 15 years. Equipment, materials, or assemblies that are nominal in cost are not included. This is therefore not a comprehensive list but does identify major expenses that are likely to be incurred in the foreseeable future.

Conditions change with time, and this evaluation, along with the funds allocated to cover the associated expenses should be reviewed and revised periodically as the Department's needs evolve. Unanticipated expenses can develop for a number of reasons including accelerated use or changes in use patterns, accident, or deferred general maintenance. Such reviews should include updating baseline costs and dates for the components or assemblies identified in this study.

Costs are calculated at 2019 levels and escalated at the following presumed annual rate of inflation:

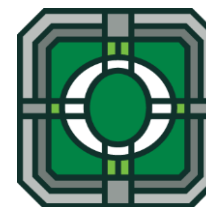
6.50% per annum

This report is broken up into different categories. The first three are organized by category with like expenses grouped together. The worksheets also covers Mechanical expenses, Electrical expenses, and Plumbing expenses. The last worksheet is organized by the computed year of expense (Budget Year).

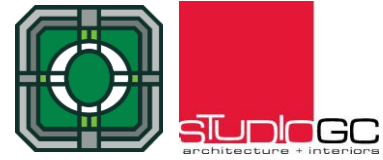
Repair/replacement work items do not include A/E Design Fees in the cost.

Total Combined Facilities

2020	\$63,820
2024	\$188,190
2044	\$139,733
2054	\$211,587
Total:	\$603,330



NAME: MALLARDS LANDING PARK
ADDRESS: 17169 Deer Run Dr, Orland Park
PARK TYPE: Neighborhood
EVALUATION YEAR: 2019



PARK MAP:



PARK DATA:

Year Renovated:	1996
Park Age:	23
Total Acreage:	10
Total Parking Spaces:	0

Amenities:

Playground Equip:	Landscape Struct
Bike/ walking Path	
Drinking Fountain	
Handicap Swing	
Pavilion	
Park Grills	

SECURITY COMMENTS:

- Park security is as to be expected for this size facility. See a few specific areas of note and one concern:
- Great visibility from public ways
 - Security lighting should be considered if law enforcement has concerns.

Score 3.00

ACCESSIBILITY COMMENTS

- The park was constructed prior to the 2010 Accessibility Code revision. There are a few items of note:
- The path to the fiber surface is not accessible.
 - The sand pit is not accessible

Score 2.88

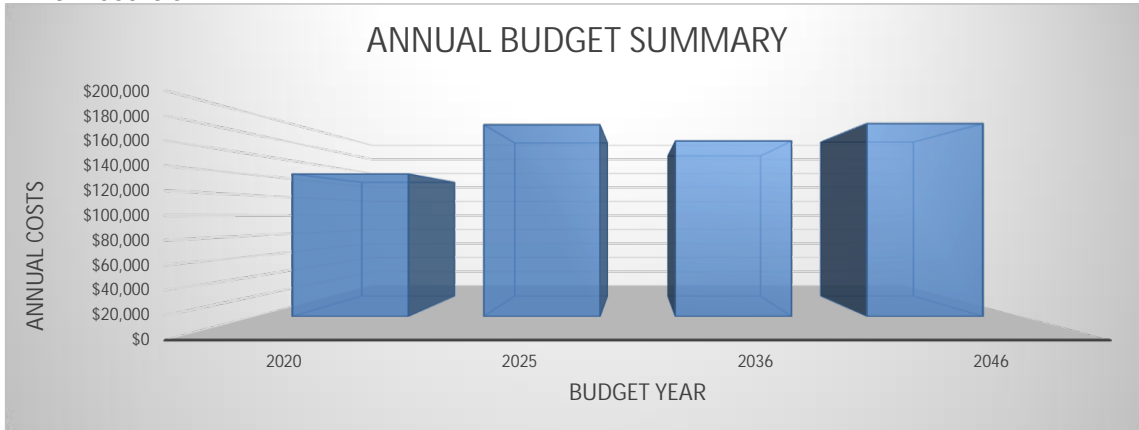
GENERAL CONDITION COMMENTS

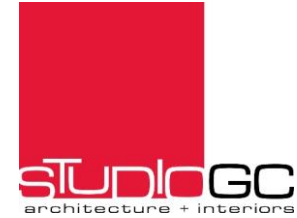
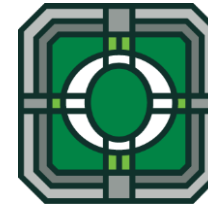
- Park is in generally good condition.
- Deterioration is cosmetic, hazed plastic, cracked panels, and rust on fittings and platforms.
 - Concrete block walls are deteriorated and loose in a number of areas.
 - Pavilion is in good shape but needs some cosmetic and carpentry touch up.

Score 2.73

Score Average 2.87

ANNUAL COSTS GRAPH:





COST BY BUDGET YEAR:

MALLARDS LANDING PARK

Budget Year	Component	Detail	Values	
			Sum of 2019 Replacement Cost	Sum of Escalated Budget
2020	PARK AMENITIES	Benches	\$2,000.00	\$2,130.00
		Trash/Recycling	\$800.00	\$852.00
		Bike Racks/Systems	\$400.00	\$426.00
	Play Component	Drinking Fountains	\$6,500.00	\$6,922.50
		Elevated Structures (2)	\$75,000.00	\$79,875.00
		Ground Equipment	\$5,000.00	\$5,325.00
		Mulch	\$27,920.00	\$29,734.80
RECREATION COMPONENTS	Fencing	\$14,750.00	\$15,708.75	
2020 Total			\$132,370.00	\$140,974.05
2025	PARK AMENITIES	Pavilion (2)	\$130,000.00	\$189,688.50
2025 Total			\$130,000.00	\$189,688.50
2036	SITE COMPONENTS	Concrete Walks	\$45,650.00	\$133,163.17
	Play Component	Edge Restraint	\$13,870.00	\$40,459.43
2036 Total			\$59,520.00	\$173,622.60
2046	SITE COMPONENTS	Landscaping	\$34,848.00	\$190,817.09
2046 Total			\$34,848.00	\$190,817.09
Grand Total			\$356,738.00	\$695,102.24

Description/Life Expectancy						Assessments			Evaluated Condition			Estimated Cost Data - 2019								
Component	Detail	Task	Installed Date	Service Life	Anticipated Replacement Date	Security (1-5)	General (1-5)	Accessibility (1-5)	Evaluation Date	Life Expectancy Modifier	Life Expectancy Beyond Evaluation (years remaining)	Budget Year	Qty	Units	Prorate	Unit Cost	2019 Replacement Cost	Escalated Budget	Comments	
			(year)	(years)	(year)	(0 is lowest)	(0 is lowest)	(0 is lowest)	(year)	%	(0 is lowest)						(As of Evaluation date)			
SITE COMPONENTS						3														
Site Components	Concrete Walks		1996	40	2036		3	3	2019	0%	0	2036	9,130	sf		\$5.00	\$45,650	\$133,163		
Site Components	Landscaping		1996	50	2046		2		2019	0%	0	2046	435,600	sf		\$0.08	\$34,848	\$190,817		
PLAY COMPONENTS																				
Play Component	Elevated Structures (2)		1996	15	2011		2	3	2019	60%	9	2020	3	each		\$25,000.00	\$75,000	\$79,875	See Accessibility Chart	
Play Component	Ground Equipment		1996	15	2011		2	3	2019	60%	9	2020	2	each		\$2,500.00	\$5,000	\$5,325	See Accessibility Chart	
Play Component	Mulch		2010	10	2020		3	2	2019	0%	0	2020	5,584	sf		\$5.00	\$27,920	\$29,735		
Play Component	Edge Restraint		1996	40	2036		4		2019	0%	0	2036	365	lf		\$38.00	\$13,870	\$40,459	Plastic Edging	
PARK AMENITIES																				
Park Amenities	Benches		1996	10	2006		3	3	2019	140%	14	2020	2	each		\$1,000.00	\$2,000	\$2,130		
Park Amenities	Trash/Recycling		1996	10	2006		3	3	2019	140%	14	2020	2	each		\$400.00	\$800	\$852		
Park Amenities	Bike Racks/Systems		1996	10	2006		3		2019	140%	14	2020	1	each		\$400.00	\$400	\$426		
Park Amenities	Drinking Fountains		1996	15	2011		3	3	2019	60%	9	2020	1	each		\$6,500.00	\$6,500	\$6,923		
Park Amenities	Pavilion (2)		2000	25	2025		2	3	2019	0%	0	2025	1,300	sf		\$100.00	\$130,000	\$189,688		
RECREATION COMPONENTS																				
Recreation Components	Fencing		1996	10	2006				2019	140%	14	2020	295	lf		\$50.00	\$14,750	\$15,709		
						3.00	2.73	2.88							\$341,988	\$679,393				

NOTES

Evaluation of building conditions focused on the elements likely to be included in the budget for items expected to require replacement or renovation within the next 10 to 15 years. Equipment, materials, or assemblies that are nominal in cost are not included. This is therefore not a comprehensive list but does identify major expenses that are likely to be incurred in the foreseeable future.

Conditions change with time, and this evaluation, along with the funds allocated to cover the associated expenses should be reviewed and revised periodically as the department's needs evolve. Unanticipated expenses can develop for a number of reasons including accelerated use or changes in use patterns, accident, or deferred general maintenance. Such reviews should include updating baseline costs and dates for the components or assemblies identified in this study.

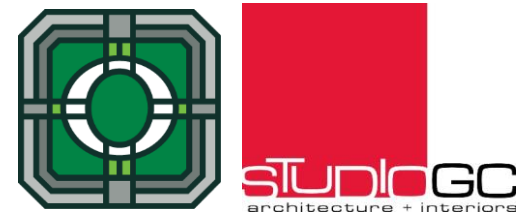
Costs are calculated at 2019 levels and escalated at the following presumed annual rate of inflation:

6.50% per annum

This report is broken up into different categories. The first three are organized by category with like expenses grouped together. The worksheets also covers Mechanical expenses, Electrical expenses, and Plumbing expenses. The last worksheet is organized by the computed year of expense (Budget Year).

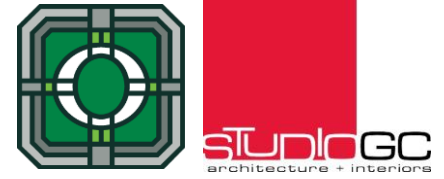
Repair/replacement work items do not include A/E Design Fees in the cost.

Total Combined Facilities	
2020	\$140,974
2025	\$189,688
2036	\$173,623
2046	\$190,817
Total:	\$695,102



NOTES

NAME: MARLEY CREEK PARK
ADDRESS: 18100 Marley Creek Blvd, Orland Park
PARK TYPE: Neighborhood
EVALUATION YEAR: 2019



PARK MAP:



PARK DATA:

Year Renovated:	1999
Park Age:	20
Total Acreage:	8.8
Total Parking Spaces	20

Amenities:

Playground Equip:	Landscape Struct.
Basketball Court	
Bike/ Walking Path	
Fishing	
Pavilion	
Picnic Grill	
Sledhill	

SECURITY COMMENTS:

- The park has a few concerns from a security viewpoint:
- Basketball court is unprotected from the parking area.
 - Park play areas is isolated and not visible from the public way.

Score **2.00**

ACCESSIBILITY COMMENTS

- The park predates the 2010 ADA guidelines and was not required to be compliant:
- Play equipment should be evaluated for compliance.
 - Asphalt paths likely exceed allowable slopes.
 - Play areas do not have accessible ramps.

Score **2.00**

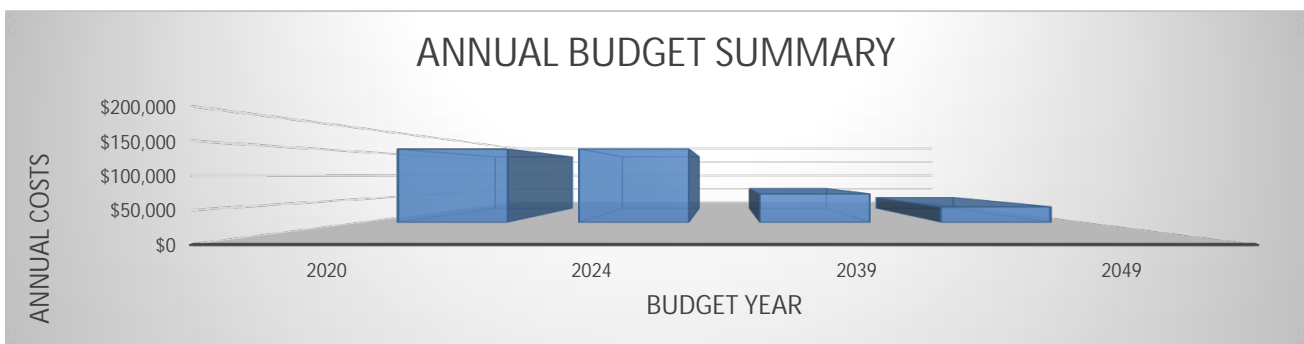
GENERAL CONDITION COMMENTS

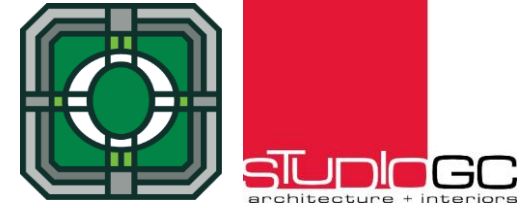
- Park is in generally good condition.
- Playground equipment has age appropriate deterioration.
 - Basketball court is in need of replacement, '

Score **2.58**

Score Average **2.19**

ANNUAL COST GRAPH:





COST BY BUDGET YEAR:

MARLEY CREEK PARK

Budget Year	Component	Detail	Values	
			Sum of 2019 Replacement Cost	Sum of Escalated Budget
2020	SITE COMPONENTS	Concrete Patios	\$18,000.00	\$19,170.00
		PARK AMENITIES	Benches	\$1,000.00
		Picnic Grills	\$1,500.00	\$1,597.50
	Play Component	Elevated Structures (2)	\$100,000.00	\$106,500.00
		Ground Equipment	\$3,600.00	\$3,834.00
		Mulch	\$7,355.00	\$7,833.08
		Sand Play Area	\$9,400.00	\$10,011.00
		Edge Restraint	\$5,662.00	\$6,030.03
2020 Total			\$146,517.00	\$156,040.61
2024	SITE COMPONENTS	Parking Spaces (20)	\$1,000.00	\$1,370.09
		Asphalt	\$70,000.00	\$95,906.07
	PARK AMENITIES	Pavilion	\$43,200.00	\$59,187.74
2024 Total			\$114,200.00	\$156,463.90
2039	SITE COMPONENTS	Concrete Walks	\$17,175.00	\$60,518.60
2039 Total			\$17,175.00	\$60,518.60
2049	SITE COMPONENTS	Landscaping	\$5,000.00	\$33,071.83
2049 Total			\$5,000.00	\$33,071.83
Grand Total			\$282,892.00	\$406,094.94

Description/Life Expectancy						Assessments			Evaluated Condition			Estimated Cost Data - 2019						Comments	
Component	Detail	Task	Installed Date	Service Life	Anticipated Replacement Date	Security (1-5)	General (1-5)	Accessibility (1-5)	Evaluation Date	Life Expectancy Modifier	Life Expectancy Beyond Evaluation (years remaining)	Budget Year	Qty	Units	Prorate	Unit Cost	2019 Replacement Cost		Escalated Budget
			(year)	(years)	(year)	(0 is lowest)	(0 is lowest)	(0 is lowest)	(year)	%	(0 is lowest)						(As of Evaluation date)		
SITE COMPONENTS						2													
Site Components	Concrete Walks		1999	40	2039		2	3	2019	0%	0	2039	3,435	sf		\$5.00	\$17,175	\$60,519	
Site Components	Concrete Patios		1999	20	2019		3		2019	5%	1	2020	1,000	sf		\$18.00	\$18,000	\$19,170	
Site Components	Landscaping		1999	50	2049		2		2019	0%	0	2049	1	ls		\$5,000.00	\$5,000	\$33,072	
Site Components	Parking Spaces (20)		1999	25	2024		3		2019	0%	0	2024	200	lf		\$5.00	\$1,000	\$1,370	
Site Components	Asphalt		1999	25	2024		3		2019	0%	0	2024	10,000	sf		\$7.00	\$70,000	\$95,906	
PLAY COMPONENTS						2													
Play Component	Elevated Structures (2)		1999	15	2014		2	2	2019	40%	6	2020	4	each		\$25,000.00	\$100,000	\$106,500	See Accessibility Chart
Play Component	Ground Equipment		1999	15	2014		2	2	2019	40%	6	2020	3	each		\$1,200.00	\$3,600	\$3,834	See Accessibility Chart
Play Component	Mulch		2010	10	2020		3	1	2019	0%	0	2020	1,471	sf		\$5.00	\$7,355	\$7,833	
Play Component	Sand Play Area		2010	10	2020		1	1	2019	0%	0	2020	200	sf		\$47.00	\$9,400	\$10,011	
Play Component	Edge Restraint		1999	40	2039		4		2019	-48%	-19	2020	149	lf		\$38.00	\$5,662	\$6,030	Plastic Edging
PARK AMENITIES						2													
Park Amenities	Benches		1999	10	2009		3	3	2019	110%	11	2020	1	each		\$1,000.00	\$1,000	\$1,065	
Park Amenities	Pavilion		1999	25	2024		3	2	2019	0%	0	2024	432	sf		\$100.00	\$43,200	\$59,188	
Park Amenities	Picnic Grills		1999	15	2014				2019	40%	6	2020	1	each		\$1,500.00	\$1,500	\$1,598	
RECREATION COMPONENTS																			
						2.00	2.58	2.00											
																	\$282,892	\$406,095	

NOTES

Evaluation of building conditions focused on the elements likely to be included in the budget for items expected to require replacement or renovation within the next 10 to 15 years. Equipment, materials, or assemblies that are nominal in cost are not included. This is therefore not a comprehensive list but does identify major expenses that are likely to be incurred in the foreseeable future.

Conditions change with time, and this evaluation, along with the funds allocated to cover the associated expenses should be reviewed and revised periodically as the Department's needs evolve. Unanticipated expenses can develop for a number of reasons including accelerated use or changes in use patterns, accident, or deferred general maintenance. Such reviews should include updating baseline costs and dates for the components or assemblies identified in this study.

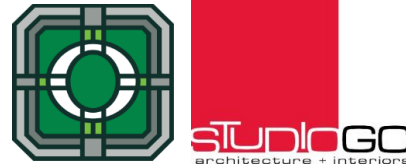
Costs are calculated at 2019 levels and escalated at the following presumed annual rate of inflation:

6.50% per annum

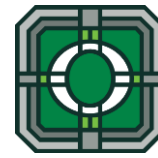
This report is broken up into different categories. The first three are organized by category with like expenses grouped together. The worksheets also covers Mechanical expenses, Electrical expenses, and Plumbing expenses. The last worksheet is organized by the computed year of expense (Budget Year).

Repair/replacement work items do not include A/E Design Fees in the cost.

Total Combined Facilities	
2020	\$156,041
2024	\$156,464
2039	\$60,519
2049	\$33,072
Total:	\$406,095



NAME: MISSION HILLS PARK
ADDRESS: 17530 San Bernardino Dr, Orland Park
PARK TYPE: Neighborhood
EVALUATION YEAR: 2019



PARK MAP:



PARK DATA:

Year Renovated:	2000
Park Age:	19
Total Acreage:	3.5
Total Parking Spaces:	0

Amenities:

Playground Equip: Little Tykes
 Basketball Court
 Climbing Wall
 Drinking Fountain
 Pavilion
 Picnic Grill

SECURITY COMMENTS:

Score **2.50**

Park security is as to be expected for this size facility. See a few specific areas of note and one concern:
 - Great visibility from public ways
 - Security lighting should be considered if law enforcement has concerns.

ACCESSIBILITY COMMENTS

Score **2.57**

The park was constructed prior to the 2010 Accessibility Code revision. There are a few items of note:
 - The path to the fiber surface is not accessible.

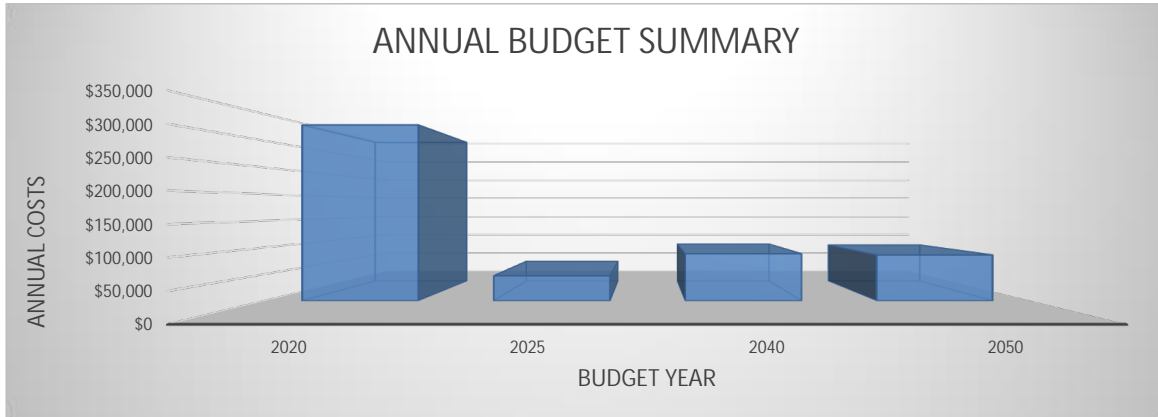
GENERAL CONDITION COMMENTS

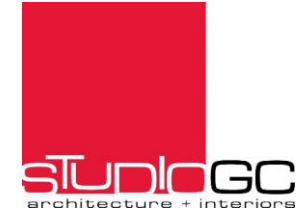
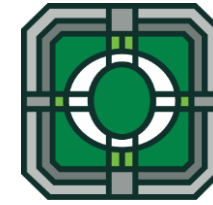
Score **2.58**

Park is in generally good condition.
 - Most deterioration is cosmetic.
 - Basketball court is ponding and the finish is significantly deteriorated.
 - Sand area is drifting onto adjacent areas
 - Asphalt paths are in need of replacement, or seal coated.

Score Average **2.55**

ANNUAL COSTS GRAPHS:





COST BY BUDGET YEAR:

MISSION HILLS PARK

Budget Year	Component	Detail	Values	
			Sum of 2019 Replacement Cost	Sum of Escalated Budget
2020	SITE COMPONENTS	Concrete Patios	\$29,394.00	\$31,304.61
		PARK AMENITIES	Benches	\$3,000.00
		Trash/Recycling	\$400.00	\$426.00
		Drinking Fountains	\$6,500.00	\$6,922.50
	Play Component	Elevated Structures (2)	\$100,000.00	\$106,500.00
		Ground Equipment	\$7,500.00	\$7,987.50
		Mulch	\$40,610.00	\$43,249.65
		Sand Play Area	\$7,050.00	\$7,508.25
		RECREATION COMPONENTS	Basketball Courts	\$115,000.00
2020 Total			\$309,454.00	\$329,568.51
2025	PARK AMENITIES	Pavilion	\$32,200.00	\$46,984.38
2025 Total			\$32,200.00	\$46,984.38
2040	SITE COMPONENTS	Concrete Walks	\$11,100.00	\$41,654.77
		Play Component	Edge Restraint	\$12,388.00
2040 Total			\$23,488.00	\$88,142.99
2050	SITE COMPONENTS	Landscaping	\$12,196.80	\$85,917.92
2050 Total			\$12,196.80	\$85,917.92
Grand Total			\$377,338.80	\$550,613.80

Description/Life Expectancy		Assessments				Evaluated Condition			Estimated Cost Data - 2019						Comments				
Component	Detail	Task	Installed Date	Service Life	Anticipated Replacement Date	Security (1-5)	General (1-5)	Accessibility (1-5)	Evaluation Date	Life Expectancy Modifier	Life Expectancy Beyond Evaluation (years remaining)	Budget Year	Qty	Units		Prorate	Unit Cost	2019 Replacement Cost	Escalated Budget
			(year)	(years)	(year)	(0 is lowest)	(0 is lowest)	(0 is lowest)	(year)	%	(0 is lowest)							(As of Evaluation date)	
SITE COMPONENTS						2													
Site Components	Concrete Walks		2000	40	2040		2	3	2019	0%	0	2040	2,220	sf		\$5.00	\$11,100	\$41,655	
Site Components	Concrete Patios		2000	20	2020		3		2019	0%	0	2020	1,633	sf		\$18.00	\$29,394	\$31,305	
Site Components	Landscaping		2000	50	2050		3		2019	0%	0	2050	152,460	sf		\$0.08	\$12,197	\$85,918	
PLAY COMPONENTS																			
Play Component	Elevated Structures (2)		2000	15	2015		3	3	2019	30%	5	2020	4	each		\$25,000.00	\$100,000	\$106,500	See Accessibility Chart
Play Component	Ground Equipment		2000	15	2015		3	3	2019	30%	5	2020	3	each		\$2,500.00	\$7,500	\$7,988	See Accessibility Chart
Play Component	Mulch		2010	10	2020		3	2	2019	0%	0	2020	8,122	sf		\$5.00	\$40,610	\$43,250	
Play Component	Sand Play Area		2010	10	2020		2	1	2019	0%	0	2020	150	sf		\$47.00	\$7,050	\$7,508	
Play Component	Edge Restraint		2000	40	2040		3		2019	0%	0	2040	326	lf		\$38.00	\$12,388	\$46,488	Plastic Edging
PARK AMENITIES																			
Park Amenities	Benches		2000	10	2010		2		2019	100%	10	2020	3	each		\$1,000.00	\$3,000	\$3,195	
Park Amenities	Trash/Recycling		2000	10	2010		2		2019	100%	10	2020	1	each		\$400.00	\$400	\$426	
Park Amenities	Drinking Fountains		2000	15	2015				2019	30%	5	2020	1	each		\$6,500.00	\$6,500	\$6,923	
Park Amenities	Pavilion		2000	25	2025		3	3	2019	0%	0	2025	322	sf		\$100.00	\$32,200	\$46,984	
RECREATION COMPONENTS						3													
Recreation Components	Basketball Courts		2000	20	2020		2	3	2019	0%	0	2020	1.0	each		\$115,000.00	\$115,000	\$122,475	
						2.50	2.58	2.57							\$377,339	\$550,614			

NOTES

Evaluation of building conditions focused on the elements likely to be included in the budget for items expected to require replacement or renovation within the next 10 to 15 years. Equipment, materials, or assemblies that are nominal in cost are not included. This is therefore not a comprehensive list but does identify major expenses that are likely to be incurred in the foreseeable future.

Conditions change with time, and this evaluation, along with the funds allocated to cover the associated expenses should be reviewed and revised periodically as the Department's needs evolve. Unanticipated expenses can develop for a number of reasons including accelerated use or changes in use patterns, accident, or deferred general maintenance. Such reviews should include updating baseline costs and dates for the components or assemblies identified in this study.

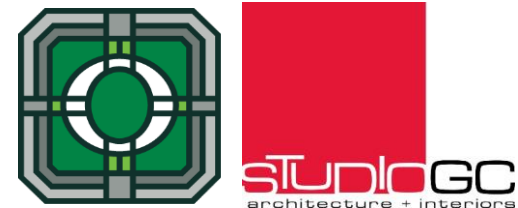
Costs are calculated at 2019 levels and escalated at the following presumed annual rate of inflation:

6.50% per annum

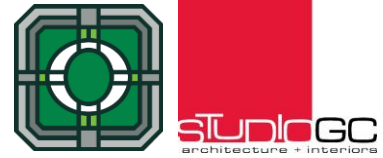
This report is broken up into different categories. The first three are organized by category with like expenses grouped together. The worksheets also covers Mechanical expenses, Electrical expenses, and Plumbing expenses. The last worksheet is organized by the computed year of expense (Budget Year).

Repair/replacement work items do not include A/E Design Fees in the cost.

Total Combined Facilities	
2020	\$329,569
2025	\$46,984
2040	\$88,143
2050	\$85,918
Total:	\$550,614



NAME: NEWBURY PARK
ADDRESS: 7910 Newbury Dr, Orland Park
PARK TYPE: Neighborhood
EVALUATION YEAR: 2019



PARK MAP:



PARK DATA:

Year Renovated:	2001
Park Age:	18
Total Acreage:	1.4
Total Parking Spaces:	0

Amenities:

Playground Equip: Gametime
 Bocce Ball
 Drinking Fountain
 Picnic Grill
 Pavilion

SECURITY COMMENTS:

Score 3.00

Park security is as to be expected for this size facility. See a few specific areas of note and one concern:
 - Great visibility from public ways
 - Security lighting should be considered if law enforcement has concerns.

ACCESSIBILITY COMMENTS

Score 2.00

The park was constructed prior to the 2010 Accessibility Code revision. There are a few items of note:
 - The path to the fiber surface is not accessible.
 - The bocce ball area is not accessible
 - Pavers and concrete have heaved causing accessibility concerns.

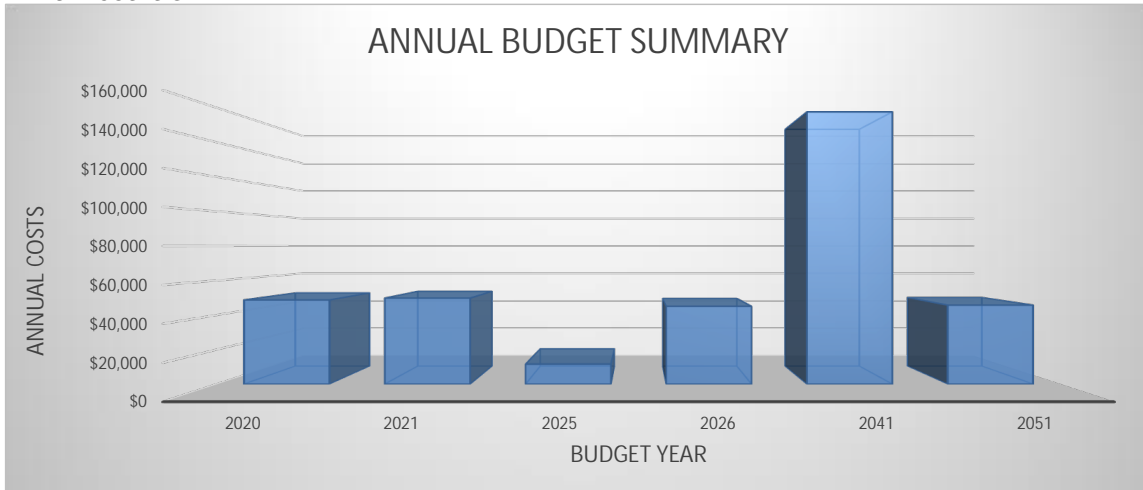
GENERAL CONDITION COMMENTS

Score 2.42

Park is in generally good condition. Most deterioration is cosmetic.
 - The edge restraint is deteriorating and in need of replacement.
 - Pavilion trim is deteriorating.
 - Pavers and concrete have heaved.

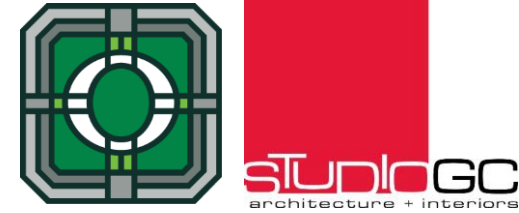
Score Average 2.47

ANNUAL COSTS GRAPH:



COST BY BUDGET YEAR:

NEWBURY PARK



Budget Year	Component	Detail	Values	
			Sum of 2019 Replacement Cost	Sum of Escalated Budget
2020	PARK AMENITIES	Benches	\$4,000.00	\$4,260.00
		Trash/Recycling	\$800.00	\$852.00
	Play Component	Mulch	\$40,974.00	\$43,637.31
2020 Total			\$45,774.00	\$48,749.31
2021	SITE COMPONENTS	Concrete Patios	\$42,426.00	\$48,120.63
	PARK AMENITIES	Picnic Grill	\$1,500.00	\$1,701.34
2021 Total			\$43,926.00	\$49,821.97
2025	RECREATION COMPON	Fencing	\$7,950.00	\$11,600.18
2025 Total			\$7,950.00	\$11,600.18
2026	PARK AMENITIES	Pavilion	\$29,000.00	\$45,065.61
2026 Total			\$29,000.00	\$45,065.61
2041	SITE COMPONENTS	Concrete Walks	\$18,975.00	\$75,835.60
	Play Component	Edge Restraint	\$20,444.00	\$81,706.62
2041 Total			\$39,419.00	\$157,542.22
2051	SITE COMPONENTS	Landscaping	\$6,098.40	\$45,751.29
2051 Total			\$6,098.40	\$45,751.29
Grand Total			\$172,167.40	\$358,530.58

NEWBURY PARK		7910 Newbury Dr, Orland Park				Assessments			Evaluated Condition			Estimated Cost Data - 2019					Comments		
Description/Life Expectancy		Task	Installed Date	Service Life	Anticipated Replacement Date	Security (1-5)	General (1-5)	Accessibility (1-5)	Evaluation Date	Life Expectancy Modifier	Life Expectancy Beyond Evaluation (years remaining)	Budget Year	Qty	Units	Prorate	Unit Cost		2019 Replacement Cost	Escalated Budget
Component	Detail		(year)	(years)	(year)	(0 is lowest)	(0 is lowest)	(0 is lowest)	(year)	%	(0 is lowest)							(As of Evaluation date)	
SITE COMPONENTS						3													
Site Components	Concrete Walks		2001	40	2041		3	3	2019	0%	0	2041	3,795	sf		\$5.00	\$18,975	\$75,836	
Site Components	Concrete Patios		2001	20	2021		3		2019	0%	0	2021	2,357	sf		\$18.00	\$42,426	\$48,121	
Site Components	Landscaping		2001	50	2051		3		2019	0%	0	2051	60,984	sf		\$0.10	\$6,098	\$45,751	
PLAY COMPONENTS																			
Play Component	Elevated Structures (2)		2001	15	2016		2	2	2019	28%	4	2020	4	each		\$25,000.00	\$100,000	\$107,850	See Accessibility Chart
Play Component	Ground Equipment		2001	15	2016		2	2	2019	28%	4	2020	6	each		\$2,500.00	\$15,000	\$16,177	See Accessibility Chart
Play Component	Mulch		2010	10	2020		2	1	2019	0%	0	2020	6,829	sf		\$6.00	\$40,974	\$43,637	
Play Component	Edge Restraint		2001	40	2041		2		2019	0%	0	2041	538	lf		\$38.00	\$20,444	\$81,707	Plastic Edging
PARK AMENITIES																			
Park Amenities	Benches		2001	10	2011		3	3	2019	90%	9	2020	4	each		\$1,000.00	\$4,000	\$4,260	
Park Amenities	Trash/Recycling		2001	10	2011		3		2019	90%	9	2020	2	each		\$400.00	\$800	\$852	
Park Amenities	Drinking Fountains		2001	15	2016				2019	28%	4	2020	1	each		\$6,500.00	\$6,500	\$7,010	
Park Amenities	Pavilion		2001	25	2026		2	2	2019	0%	0	2026	290	sf		\$100.00	\$29,000	\$45,066	
Park Amenities	Picnic Grill		2001	20	2021				2019	0%	0	2021	1	each		\$1,500.00	\$1,500	\$1,701	
RECREATION COMPONENTS																			
Recreation Components	Bocce Ball		2001				2	1					1	each					
Recreation Components	Fencing		2001	24	2025		2		2019	0%	0	2025	159	lf		\$50.00	\$7,950	\$11,600	
						3.00	2.42	2.00						\$285,717	\$477,968				

NOTES

Evaluation of building conditions focused on the elements likely to be included in the budget for items expected to require replacement or renovation within the next 10 to 15 years. Equipment, materials, or assemblies that are nominal in cost are not included. This is therefore not a comprehensive list but does identify major expenses that are likely to be incurred in the foreseeable future.

Conditions change with time, and this evaluation, along with the funds allocated to cover the associated expenses should be reviewed and revised periodically as the Department's needs evolve. Unanticipated expenses can develop for a number of reasons including accelerated use or changes in use patterns, accident, or deferred general maintenance. Such reviews should include updating baseline costs and dates for the components or assemblies identified in this study.

Costs are calculated at 2019 levels and escalated at the following presumed annual rate of inflation:

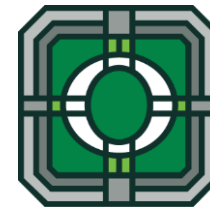
6.50% per annum

This report is broken up into different categories. The first three are organized by category with like expenses grouped together. The worksheets also covers Mechanical expenses, Electrical expenses, and Plumbing expenses. The last worksheet is organized by the computed year of expense (Budget Year).

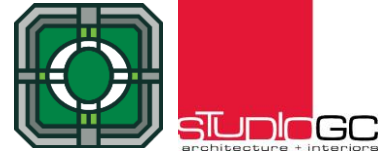
Repair/replacement work items do not include A/E Design Fees in the cost.

Total Combined Facilities

2020	\$48,749
2021	\$49,822
2025	\$11,600
2026	\$45,066
2041	\$157,542
2051	\$45,751
Total	\$358,531



NAME: ORLAND WOODS
ADDRESS: 11605 Kiley Lane, Orland Park
PARK TYPE: Mini
EVALUATION YEAR: 2019



PARK MAP:



PARK DATA:

Year Renovated:	1998
Park Age:	21
Total Acreage:	9
Total Parking Spaces:	0

Amenities:

Playground Equip: Landscape Struct

SECURITY COMMENTS:

- There are a few security concerns:
- Trimming the landscape and shrubs would help immensely.
- Security lighting should be considered if law enforcement has concerns.

Score **2.67**

ACCESSIBILITY COMMENTS

- The park was constructed prior to the 2010 Accessibility Code revision. There are a few items of note:
- The path to the fiber surface is not accessible.
- The sand pit is not accessible for play.

Score **2.20**

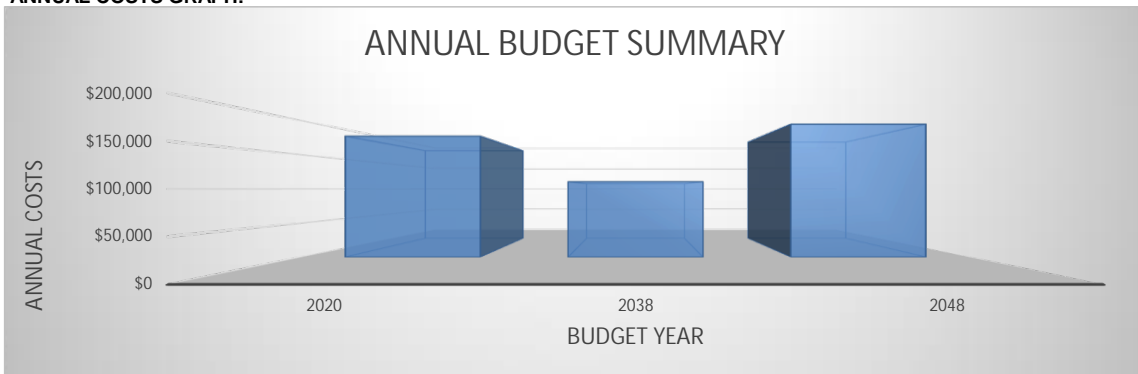
GENERAL CONDITION COMMENTS

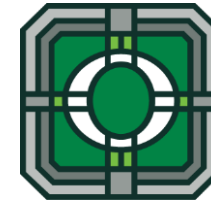
- Park is in generally good condition.
- Most deterioration is cosmetic.
- Sand pit is in poor condition and has bee nests in the sand.

Score **3.00**

Score Average **2.62**

ANNUAL COSTS GRAPH:





COST BY BUDGET YEAR:

ORLAND WOODS

Budget Year	Component	Detail	Values	
			Sum of 2019 Replacement Cost	Sum of Escalated Budget
2020	PARK AMENITIES	Benches	\$4,000.00	\$4,260.00
		Trash/Recycling	\$2,400.00	\$2,556.00
	Play Component	Elevated Structures (2)	\$80,000.00	\$85,200.00
		Ground Equipment	\$16,000.00	\$17,040.00
		Mulch	\$40,590.00	\$43,228.35
		Sand Area	\$23,500.00	\$25,027.50
2020 Total			\$166,490.00	\$177,311.85
2038	SITE COMPONENTS	Concrete Walks	\$15,000.00	\$49,628.80
		Play Component	Edge Restraint	\$18,392.00
2038 Total			\$33,392.00	\$110,480.33
2048	SITE COMPONENTS	Landscaping	\$31,363.20	\$194,786.56
2048 Total			\$31,363.20	\$194,786.56
Grand Total			\$231,245.20	\$482,578.75

Description/Life Expectancy						Assessments			Evaluated Condition			Estimated Cost Data - 2019									
Component	Detail	Task	Installed Date	Service Life	Anticipated Replacement Date	Security (1-5)	General (1-5)	Accessibility (1-5)	Evaluation Date	Life Expectancy Modifier	Life Expectancy Beyond Evaluation (years remaining)	Budget Year	Qty	Units	Prorate	Unit Cost	2019 Replacement Cost	Escalated Budget	Comments		
			(year)	(years)	(year)	(0 is lowest)	(0 is lowest)	(0 is lowest)	(year)	%	(0 is lowest)						(As of Evaluation date)				
SITE COMPONENTS						3															
Site Components	Concrete Walks		1998	40	2038		3	3	2019	0%	0	2038	3,000	sf		\$5.00	\$15,000	\$49,629			
Site Components	Landscaping		1998	50	2048				2019	0%	0	2048	392,040	sf		\$0.08	\$31,363	\$194,787			
PLAY COMPONENTS						3															
Play Component	Elevated Structures (2)		1998	15	2013		3	3	2019	45%	7	2020	4	each		\$20,000.00	\$80,000	\$85,200	See Accessibility Chart		
Play Component	Ground Equipment		1998	15	2013		2	3	2019	45%	7	2020	5	each		\$3,200.00	\$16,000	\$17,040	See Accessibility Chart		
Play Component	Mulch		2010	10	2020		3	1	2019	0%	0	2020	8,118	sf		\$5.00	\$40,590	\$43,228			
Play Component	Sand Area		2010	10	2020		3	1	2019	0%	0	2020	500	sf		\$47.00	\$23,500	\$25,028			
Play Component	Edge Restraint		1998	40	2038		4		2019	-50%	0	2038	484	lf		\$38.00	\$18,392	\$60,852	Plastic Edging		
PARK AMENITIES						2															
Park Amenities	Benches		1998	10	2008		3		2019	120%	12	2020	4	each		\$1,000.00	\$4,000	\$4,260			
Park Amenities	Trash/Recycling		1998	10	2008		3		2019	120%	12	2020	2	each		\$1,200.00	\$2,400	\$2,556			
						2.67	3.00	2.20											\$231,245	\$482,579	

NOTES

Evaluation of building conditions focused on the elements likely to be included in the budget for items expected to require replacement or renovation within the next 10 to 15 years. Equipment, materials, or assemblies that are nominal in cost are not included. This is therefore not a comprehensive list but does identify major expenses that are likely to be incurred in the foreseeable future.

Conditions change with time, and this evaluation, along with the funds allocated to cover the associated expenses should be reviewed and revised periodically as the Department's needs evolve. Unanticipated expenses can develop for a number of reasons including accelerated use or changes in use patterns, accident, or deferred general maintenance. Such reviews should include updating baseline costs and dates for the components or assemblies identified in this study.

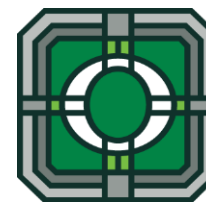
Costs are calculated at 2019 levels and escalated at the following presumed annual rate of inflation:

6.50% per annum

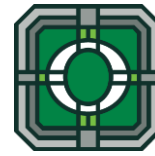
This report is broken up into different categories. The first three are organized by category with like expenses grouped together. The worksheets also covers Mechanical expenses, Electrical expenses, and Plumbing expenses. The last worksheet is organized by the computed year of expense (Budget Year).

Repair/replacement work items do not include A/E Design Fees in the cost.

Total Combined Facilities	
2020	\$177,312
2038	\$110,480
2048	\$194,787
Total:	\$482,579



NAME: PARKVIEW PARK
ADDRESS: 8753 Butterfield Ln, Orland Park
PARK TYPE: Mini
EVALUATION YEAR: 2019



PARK MAP:



PARK DATA:

Year Renovated:	1998
Park Age:	21
Total Acreage:	3.9
Total Parking Spaces:	0

Amenities:

Playground Equip: Landscape Struct.
 Fishing

SECURITY COMMENTS:

Score **3.00**

Park security is as to be expected for this size facility. See a few specific areas of note and one concern:

- Great visibility from public ways
- Security lighting should be considered if law enforcement has concerns.

ACCESSIBILITY COMMENTS

Score **2.00**

The park was constructed prior to the 2010 Accessibility Code revision. There are a few items of note:

- The path to the fiber surface is not accessible.
- Sidewalks provide a good level of accessibility and are generally free from heaving.
- Playground equipment will require additional evaluation to determine ADA compliance

GENERAL CONDITION COMMENTS

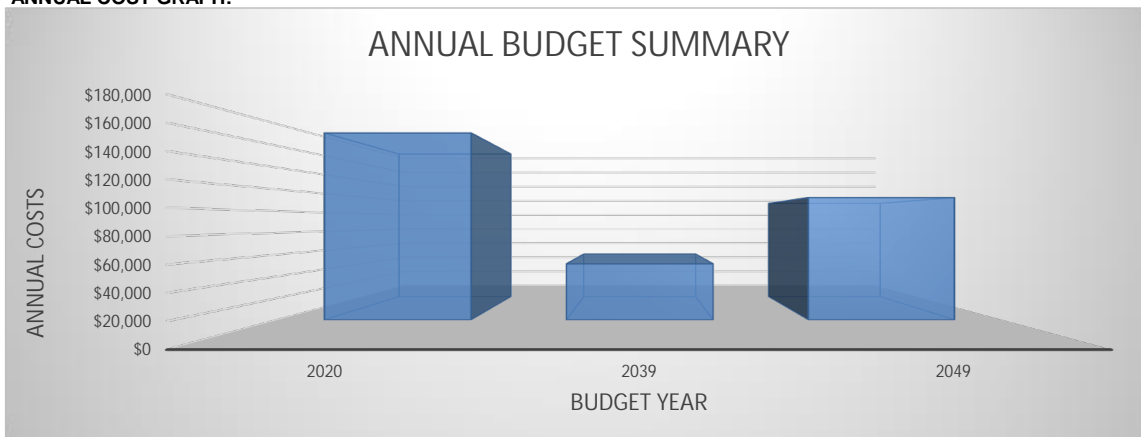
Score **2.33**

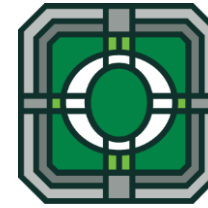
The park is in exceptional condition given it's age.

- Much of the play equipment has aged well and has only minimal deterioration requiring spot repair.
- The edge restraint (plastic curbing) is in poor condition and one the verge of failure. The curbs are leaning and need to be re=anchored

Score Average **2.44**

ANNUAL COST GRAPH:





COST BY BUDGET YEAR:

PARKVIEW PARK

Budget Year	Component	Detail	Values	
			Sum of 2019 Replacement Cost	Sum of Escalated Budget
2020	PARK AMENITIES	Benches	\$6,000.00	\$6,390.00
		Trash/Recycling	\$800.00	\$852.00
	Play Component	Elevated Structures (2)	\$75,000.00	\$79,875.00
		Ground Equipment	\$6,000.00	\$6,390.00
		Mulch	\$38,470.18	\$40,970.74
		Edge Restraint	\$14,023.10	\$14,934.60
	RECREATION COMPONENTS	Fencing	\$20,936.68	\$22,297.56
2020 Total			\$161,229.96	\$171,709.90
2039	SITE COMPONENTS	Concrete Walks	\$14,600.00	\$51,445.22
2039 Total			\$14,600.00	\$51,445.22
2049	SITE COMPONENTS	Landscaping	\$16,988.40	\$112,367.50
2049 Total			\$16,988.40	\$112,367.50
Grand Total			\$192,818.36	\$335,522.62

Description/Life Expectancy						Assessments			Evaluated Condition			Estimated Cost Data - 2019						Comments	
Component	Detail	Task	Installed Date	Service Life	Anticipated Replacement Date	Security (1-5)	General (1-5)	Accessibility (1-5)	Evaluation Date	Life Expectancy Modifier	Life Expectancy Beyond Evaluation (years remaining)	Budget Year	Qty	Units	Prorate	Unit Cost	2019 Replacement Cost		Escalated Budget
			(year)	(years)	(year)	(0 is lowest)	(0 is lowest)	(0 is lowest)	(year)	%	(0 is lowest)						(As of Evaluation date)		
SITE COMPONENTS						3													
Site Components	Concrete Walks		1999	40	2039		3		2019	0%	0	2039	2,920	sf		\$5.00	\$14,600	\$51,445	
Site Components	Landscaping		1999	50	2049		2		2019	0%	0	2049	169,884	sf		\$0.10	\$16,988	\$112,367	
PLAY COMPONENTS						3													
Play Component	Elevated Structures (2)		1999	15	2014		2	2	2019	40%	6	2020	3	each		\$25,000.00	\$75,000	\$79,875	See Accessibility Chart
Play Component	Ground Equipment		1999	15	2014		2	2	2019	40%	6	2020	5	each		\$1,200.00	\$6,000	\$6,390	See Accessibility Chart
Play Component	Mulch		2012	8	2020		3	1	2019	0%	0	2020	7,694	sf		\$5.00	\$38,470	\$40,971	
Play Component	Edge Restraint		1999	40	2039		1		2019	-48%	-19	2020	369	lf		\$38.00	\$14,023	\$14,935	Plastic Edging
PARK AMENITIES						3													
Park Amenities	Benches		1999	10	2009		2	3	2019	110%	11	2020	6	each		\$1,000.00	\$6,000	\$6,390	
Park Amenities	Trash/Recycling		1999	10	2009		2		2019	110%	11	2020	2	each		\$400.00	\$800	\$852	
RECREATION COMPONENTS						3													
Recreation Components	Fencing		1999	10	2009		4		2019	110%	11	2020	419	lf		\$50.00	\$20,937	\$22,298	
						3.00	2.33	2.00							\$171,882	\$313,225			

NOTES

Evaluation of building conditions focused on the elements likely to be included in the budget for items expected to require replacement or renovation within the next 10 to 15 years. Equipment, materials, or assemblies that are nominal in cost are not included. This is therefore not a comprehensive list but does identify major expenses that are likely to be incurred in the foreseeable future.

Conditions change with time, and this evaluation, along with the funds allocated to cover the associated expenses should be reviewed and revised periodically as the department's needs evolve. Unanticipated expenses can develop for a number of reasons including accelerated use or changes in use patterns, accident, or deferred general maintenance. Such reviews should include updating baseline costs and dates for the components or assemblies identified in this study.

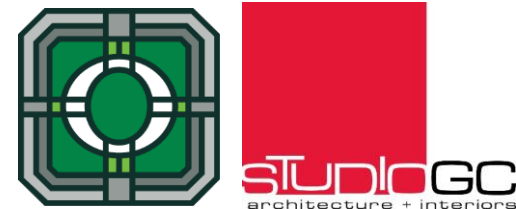
Costs are calculated at 2019 levels and escalated at the following presumed annual rate of inflation:

6.50% per annum

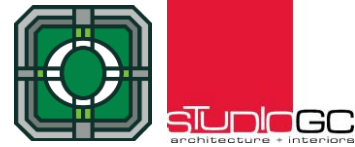
This report is broken up into different categories. The first three are organized by category with like expenses grouped together. The worksheets also covers Mechanical expenses, Electrical expenses, and Plumbing expenses. The last worksheet is organized by the computed year of expense (Budget Year).

Repair/replacement work items do not include A/E Design Fees in the cost.

Total Combined Facilities	
2020	\$171,710
2039	\$51,445
2049	\$112,367
Total:	\$335,523



NAME: PERMINAS PARK
ADDRESS: 14201 Cristina Ave, Orland Park
PARK TYPE: Neighborhood
EVALUATION YEAR: 2019



PARK MAP:



PARK DATA:

Year Renovated:	2000
Park Age	19
Total Acreage:	6.1
Total Parking Space:	0

Amenities:

Playground	Little Tykes/Gametime
Baseball/ Softball Field	1
Basketball Court	
Drinking Fountain	
Handicap Swing	
Tennis Court	1

SECURITY COMMENTS:

Park security is as to be expected for this size facility. See a few specific areas of note and one concern:
 - Great visibility from public ways
 - Security lighting should be considered if law enforcement has concerns.

Score **3.00**

ACCESSIBILITY COMMENTS

The park was constructed prior to the 2010 Accessibility Code revision. There are a few items of note:
 - The path to the fiber surface is not accessible.
 - The baseball and basketball courts are not accessible.

Score **2.29**

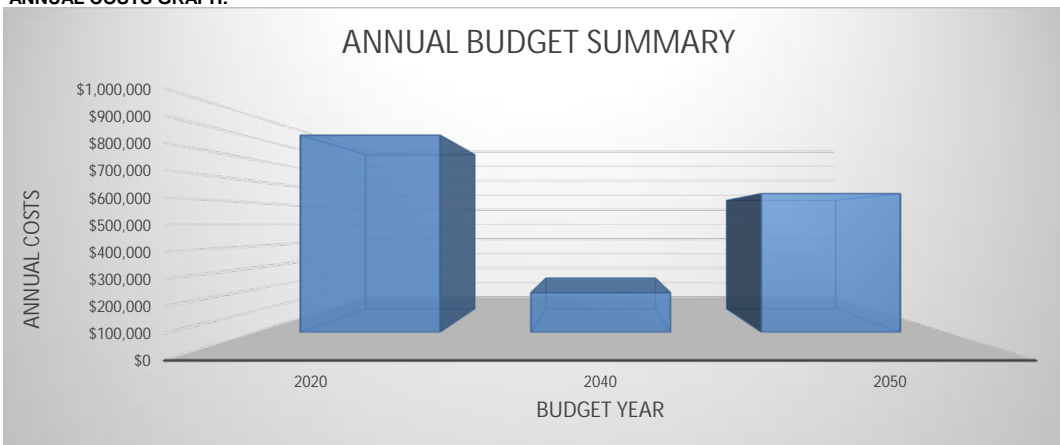
GENERAL CONDITION COMMENTS

Park is in generally good condition.
 - Most deterioration on the play equipment is cosmetic.
 - There is significant deterioration on the recreational courts.
 - Edge restraint (plastic curbing) is failing
 - Basketball surface needs repainting

Score **2.00**

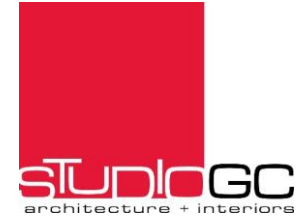
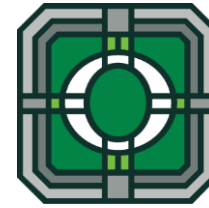
Score Average **2.43**

ANNUAL COSTS GRAPH:



COST BY BUDGET YEAR:

PERMINAS PARK



Budget Year	Component	Detail	Values		
			Sum of 2019 Replacement Cost	Sum of Escalated Budget	
2020	PARK AMENITIES	Benches	\$2,000.00	\$2,130.00	
		Trash/Recycling	\$1,200.00	\$1,278.00	
		Drinking Fountains		\$6,500.00	\$6,922.50
	Play Component	Elevated Structures (2)	\$112,000.00	\$119,280.00	
		Ground Equipment	\$20,000.00	\$21,300.00	
		Mulch	\$29,816.00	\$31,754.04	
	RECREATION COMPONENTS	Edge Restraint		\$71,437.01	\$76,080.42
		Basketball Courts	\$345,000.00	\$367,425.00	
		Tennis Court	\$270,000.00	\$287,550.00	
2020 Total			\$857,953.01	\$913,719.96	
2040	SITE COMPONENTS	Concrete Walks	\$48,800.00	\$183,130.88	
2040 Total			\$48,800.00	\$183,130.88	
2050	SITE COMPONENTS	Landscaping	\$21,257.28	\$149,742.66	
	RECREATION COMPONENTS	Baseball Field	\$70,000.00	\$493,101.00	
2050 Total			\$91,257.28	\$642,843.65	
Grand Total			\$998,010.29	\$1,739,694.49	

Description/Life Expectancy						Assessments			Evaluated Condition			Estimated Cost Data - 2019					Comments		
Component	Detail	Task	Installed Date	Service Life	Anticipated Replacement Date	Security (1-5)	General (1-5)	Accessibility (1-5)	Evaluation Date	Life Expectancy Modifier	Life Expectancy Beyond Evaluation (years remaining)	Budget Year	Qty	Units	Prorate	Unit Cost		2019 Replacement Cost	Escalated Budget
			(year)	(years)	(year)	(0 is lowest)	(0 is lowest)	(0 is lowest)	(year)	%	(0 is lowest)							(As of Evaluation date)	
SITE COMPONENTS						3													
Site Components	Concrete Walks		2000	40	2040		2		2019	0%	0	2040	9,760	sf		\$5.00	\$48,800	\$183,131	
Site Components	Landscaping		2000	50	2050				2019	0%	0	2050	265,716	sf		\$0.08	\$21,257	\$149,743	
PLAY COMPONENTS																			
Play Component	Elevated Structures (2)		2000	15	2015		3	4	2019	34%	5	2020	4	each		\$28,000.00	\$112,000	\$119,280	See Accessibility Chart
Play Component	Ground Equipment		2000	15	2015		3	3	2019	34%	5	2020	8	each		\$2,500.00	\$20,000	\$21,300	See Accessibility Chart
Play Component	Mulch		2010	10	2020		3	2	2019	0%	0	2020	5,963	sf		\$5.00	\$29,816	\$31,754	
Play Component	Edge Restraint		2000	40	2040		1		2019	-49%	-20	2020	1,880	lf		\$38.00	\$71,437	\$76,080	Plastic Edging
PARK AMENITIES																			
Park Amenities	Benches		2000	10	2010		2	3	2019	100%	10	2020	2	each		\$1,000.00	\$2,000	\$2,130	
Park Amenities	Trash/Recycling		2000	10	2010		2		2019	100%	10	2020	3	each		\$400.00	\$1,200	\$1,278	
Park Amenities	Drinking Fountains		2000	15	2015				2019	35%	5	2020	1	each		\$6,500.00	\$6,500	\$6,923	
RECREATION COMPONENTS																			
Recreation Components	Basketball Courts		2000	20	2020		1	1	2019	0%	0	2020	3.0	each		\$115,000.00	\$345,000	\$367,425	
Recreation Components	Baseball Field		2000	50	2050		2	1	2019	0%	0	2050	2	each		\$35,000.00	\$70,000	\$493,101	
Recreation Components	Tennis Court		2000	20	2020		1	2	2019	0%	0	2020	2	each		\$135,000.00	\$270,000	\$287,550	
						3.00	2.00	2.29									\$998,010	\$1,739,694	

NOTES

Evaluation of building conditions focused on the elements likely to be included in the budget for items expected to require replacement or renovation within the next 10 to 15 years. Equipment, materials, or assemblies that are nominal in cost are not included. This is therefore not a comprehensive list but does identify major expenses that are likely to be incurred in the foreseeable future.

Conditions change with time, and this evaluation, along with the funds allocated to cover the associated expenses should be reviewed and revised periodically as the Department's needs evolve. Unanticipated expenses can develop for a number of reasons including accelerated use or changes in use patterns, accident, or deferred general maintenance. Such reviews should include updating baseline costs and dates for the components or assemblies identified in this study.

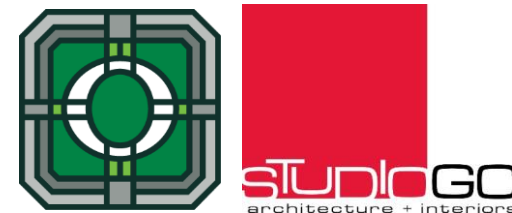
Costs are calculated at 2019 levels and escalated at the following presumed annual rate of inflation:

6.50% per annum

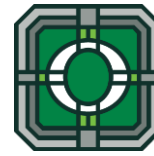
This report is broken up into different categories. The first three are organized by category with like expenses grouped together. The worksheets also covers Mechanical expenses, Electrical expenses, and Plumbing expenses. The last worksheet is organized by the computed year of expense (Budget Year).

Repair/replacement work items do not include A/E Design Fees in the cost.

Total Combined Facilities	
2020	\$913,720
2040	\$183,131
2050	\$642,844
Total:	\$1,739,694



NAME: PULTE PARK
ADDRESS: 9105 Carlisle Ln, Orland Park
PARK TYPE: Mini
EVALUATION YEAR: 2019



PARK MAP:



PARK DATA:

Year Renovated:	1998
Park Age:	21
Total Acreage:	0.5
Total Parking Spaces:	0

Amenities:

Playground Little Tykes

SECURITY COMMENTS:

Score **2.00**

- Park security is as to be expected for this size facility. See a few specific areas of note and one concern:
- Poor visibility from public ways
 - Security lighting should be considered if law enforcement has concerns.
 - Trimming the landscape and shrubs would help immensely.

ACCESSIBILITY COMMENTS

Score **2.20**

- The park was constructed prior to the 2010 Accessibility Code revision. There are a few items of note:
- The path to the fiber surface is not accessible.
 - Playground equipment will require additional evaluation to determine ADA compliance
 - The sand pit is not accessible

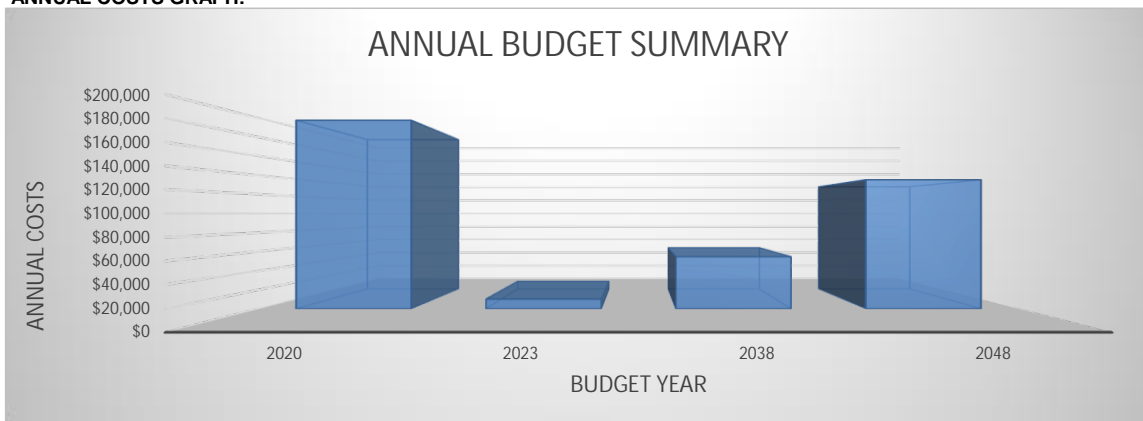
GENERAL CONDITION COMMENTS

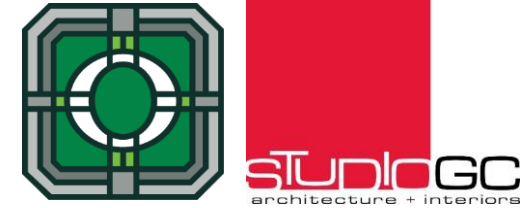
Score **2.00**

- Park is in generally good condition. Most deterioration is cosmetic.
- The edge restraint is significantly deteriorated and is not allowing the mulch to be adequately maintained.
 - Sand pit is likely to have bees, these have been present at most other parks with sand play areas. Additionally the sand pit has eroded to adjacent areas.

Score Average **2.07**

ANNUAL COSTS GRAPH:





COST BY BUDGET YEAR:

PULTE PARK

Budget Year	Component	Detail	Values	
			Sum of 2019 Replacement Cost	Sum of Escalated Budget
2020	PARK AMENITIES	Benches	\$2,000.00	\$2,130.00
		Trash/Recycling	\$400.00	\$426.00
	Play Component	Elevated Structures (2)	\$140,000.00	\$149,100.00
		Ground Equipment	\$15,000.00	\$15,975.00
		Mulch	\$26,958.19	\$28,710.47
		Sand play area	\$1,200.00	\$1,278.00
2020 Total			\$185,558.19	\$197,619.47
2023	RECREATION COMPONENTS	Fencing	\$7,933.07	\$10,205.63
2023 Total			\$7,933.07	\$10,205.63
2038	SITE COMPONENTS	Concrete Walks	\$3,300.00	\$10,918.34
		Play Component	Edge Restraint	\$13,215.22
2038 Total			\$16,515.22	\$54,642.05
2048	SITE COMPONENTS	Landscaping	\$21,780.00	\$135,268.45
2048 Total			\$21,780.00	\$135,268.45
Grand Total			\$231,786.48	\$397,735.60

PULTE PARK		9105 Carlisle Ln, Orland Park				Assessments			Evaluated Condition			Estimated Cost Data - 2019						Comments	
Description/Life Expectancy		Task	Installed Date	Service Life	Anticipated Replacement Date	Security (1-5)	General (1-5)	Accessibility (1-5)	Evaluation Date	Life Expectancy Modifier	Life Expectancy Beyond Evaluation (years remaining)	Budget Year	Qty	Units	Prorate	Unit Cost	2019 Replacement Cost		Escalated Budget
Component	Detail		(year)	(years)	(year)	(0 is lowest)	(0 is lowest)	(0 is lowest)	(year)	%	(0 is lowest)						(As of Evaluation date)		
SITE COMPONENTS						2													
Site Components	Concrete Walks		1998	40	2038		2	2	2019	0%	0	2038	660	sf		\$5.00	\$3,300	\$10,918	
Site Components	Landscaping		1998	50	2048				2019	0%	0	2048	21,780	sf		\$1.00	\$21,780	\$135,268	
PLAY COMPONENTS																			
Play Component	Elevated Structures (2)		1998	15	2013		4	3	2019	48%	7	2020	4	each		\$35,000.00	\$140,000	\$149,100	See Accessibility Chart
Play Component	Ground Equipment		1998	15	2013		4	3	2019	48%	7	2020	6	each		\$2,500.00	\$15,000	\$15,975	See Accessibility Chart
Play Component	Mulch		2010	10	2020		2	2	2019	0%	0	2020	5,392	sf		\$5.00	\$26,958	\$28,710	
Play Component	Sand play area		2010	10	2020		1	1	2019	0%	0	2020	200	sf		\$6.00	\$1,200	\$1,278	
Play Component	Edge Restraint		1998	40	2038		1		2019	0%	0	2038	348	lf		\$38.00	\$13,215	\$43,724	Plastic Edging
PARK AMENITIES																			
Park Amenities	Benches		1998	10	2008		1		2019	120%	12	2020	2	each		\$1,000.00	\$2,000	\$2,130	
Park Amenities	Trash/Recycling		1998	10	2008		1		2019	120%	12	2020	1	each		\$400.00	\$400	\$426	
RECREATION COMPONENTS																			
Recreation Components	Fencing		1998	25	2023				2019	0%	0	2023	159	lf		\$50.00	\$7,933	\$10,206	
						2.00	2.00	2.20									\$223,853	\$387,530	

NOTES

Evaluation of building conditions focused on the elements likely to be included in the budget for items expected to require replacement or renovation within the next 10 to 15 years. Equipment, materials, or assemblies that are nominal in cost are not included. This is therefore not a comprehensive list but does identify major expenses that are likely to be incurred in the foreseeable future.

Conditions change with time, and this evaluation, along with the funds allocated to cover the associated expenses should be reviewed and revised periodically as the Department's needs evolve. Unanticipated expenses can develop for a number of reasons including accelerated use or changes in use patterns, accident, or deferred general maintenance. Such reviews should include updating baseline costs and dates for the components or assemblies identified in this study.

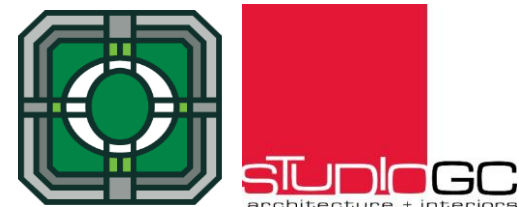
Costs are calculated at 2019 levels and escalated at the following presumed annual rate of inflation:

6.50% per annum

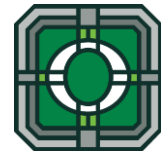
This report is broken up into different categories. The first three are organized by category with like expenses grouped together. The worksheets also covers Mechanical expenses, Electrical expenses, and Plumbing expenses. The last worksheet is organized by the computed year of expense (Budget Year).

Repair/replacement work items do not include A/E Design Fees in the cost.

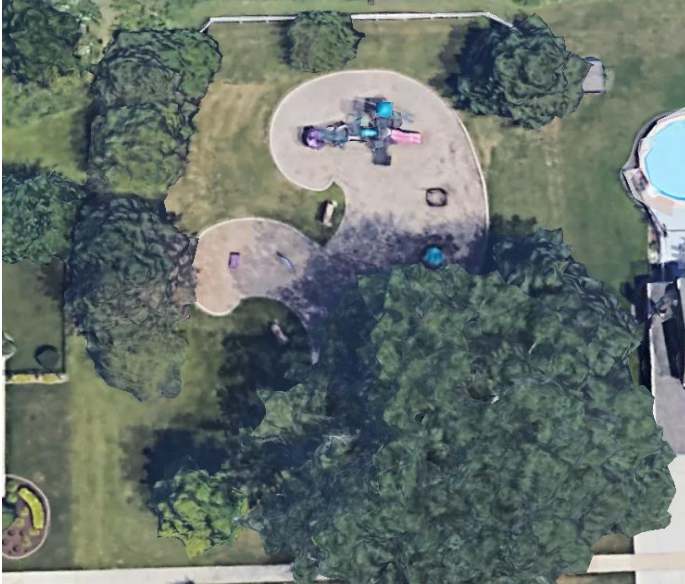
Total Combined Facilities	
2020	\$197,619
2023	\$10,206
2038	\$54,642
2048	\$135,268
Total:	\$397,736



NAME: QUINTANA PARK
ADDRESS: 8338 138TH Place, Orland Park
PARK TYPE: Mini
EVALUATION YEAR: 2019



PARK MAP:



PARK DATA:

Year Renovated:	1998
Park Age:	21
Total Acreage:	5.7
Total Parking Spaces:	0

Amenities:

Playground Equip: Landscape Struct
 Fishing

SECURITY COMMENTS:

Score 3.00

Park security is as to be expected for this size facility. See a few specific areas of note and one concern:
 - Great visibility from public ways
 - Security lighting should be considered if law enforcement has concerns.

ACCESSIBILITY COMMENTS

Score 2.00

The park was constructed prior to the 2010 Accessibility Code revision. There are a few items of note:
 - The path to the fiber surface is not accessible.
 - Playground equipment will require additional evaluation to determine ADA compliance

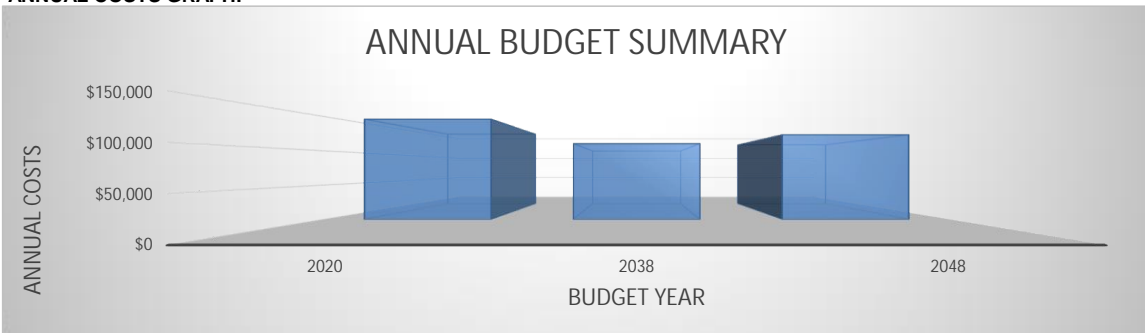
GENERAL CONDITION COMMENTS

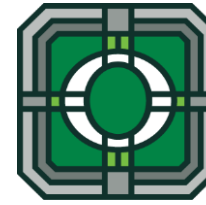
Score 3.00

Park is in generally good condition.
 - Most deterioration is cosmetic.
 - Ground equipment has reached the end of the useful life and is starting to be a safety concern.

Score Average 2.67

ANNUAL COSTS GRAPH:





COST BY BUDGET YEAR:

QUINTANA PARK

Budget Year	Component	Detail	Values	
			Sum of 2019 Replacement Cost	Sum of Escalated Budget
2020	PARK AMENITIES	Benches	\$3,000.00	\$3,195.00
		Trash/Recycling	\$400.00	\$426.00
	Play Component	Elevated Structures (2)	\$75,000.00	\$79,875.00
		Ground Equipment	\$12,500.00	\$13,312.50
		Mulch	\$26,990.48	\$28,744.86
	RECREATION COMP	Fencing	\$19,143.70	\$20,388.04
2020 Total			\$137,034.18	\$145,941.40
2038	SITE COMPONENTS	Concrete Walks	\$19,455.75	\$64,371.04
		Play Component	Edge Restraint	\$13,925.85
2038 Total			\$33,381.60	\$110,445.93
2048	SITE COMPONENTS	Landscaping	\$19,863.36	\$123,364.82
2048 Total			\$19,863.36	\$123,364.82
Grand Total			\$190,279.14	\$379,752.16

Description/Life Expectancy		Task	Installed Date	Service Life	Anticipated Replacement Date	Assessments			Evaluated Condition			Estimated Cost Data - 2019					Comments			
Component	Detail		(year)	(years)	(year)	Security (1-5)	General (1-5)	Accessibility (1-5)	Evaluation Date	Life Expectancy Modifier	Life Expectancy Beyond Evaluation (years remaining)	Budget Year	Qty	Units	Prorate	Unit Cost		2019 Replacement Cost	Escalated Budget	
						(0 is lowest)	(0 is lowest)	(0 is lowest)	(year)	%	(0 is lowest)							(As of Evaluation date)		
SITE COMPONENTS						3														
Site Components	Concrete Walks		1998	40	2038		3		2019	0%	0	2038	3,891	sf		\$5.00	\$19,456	\$64,371		
Site Components	Landscaping		1998	50	2048		3		2019	0%	0	2048	248,292	sf		\$0.08	\$19,863	\$123,365		
PLAY COMPONENTS						3														
Play Component	Elevated Structures (2)		1998	15	2013		3	3	2019	47%	7	2020	3	each		\$25,000.00	\$75,000	\$79,875	See Accessibility Chart	
Play Component	Ground Equipment		1998	15	2013		2	3	2019	47%	7	2020	5	each		\$2,500.00	\$12,500	\$13,313	See Accessibility Chart	
Play Component	Mulch		1998	10	2008		3	1	2019	120%	12	2020	5,398	sf		\$5.00	\$26,990	\$28,745		
Play Component	Edge Restraint		1998	40	2038		5		2019	0%	0	2038	366	lf		\$38.00	\$13,926	\$46,075	Plastic Edging	
PARK AMENITIES						3														
Park Amenities	Benches		1998	10	2008		2	1	2019	120%	12	2020	3	each		\$1,000.00	\$3,000	\$3,195		
Park Amenities	Trash/Recycling		1998	10	2008				2019	120%	12	2020	1	each		\$400.00	\$400	\$426		
RECREATION COMPONENTS						3														
Recreation Components	Fencing		1998	10	2008		3		2019	120%	12	2020	128	lf		\$150.00	\$19,144	\$20,388		
						3.00	3.00	2.00												
																	\$171,135	\$359,364		

NOTES

Evaluation of building conditions focused on the elements likely to be included in the budget for items expected to require replacement or renovation within the next 10 to 15 years. Equipment, materials, or assemblies that are nominal in cost are not included. This is therefore not a comprehensive list but does identify major expenses that are likely to be incurred in the foreseeable future.

Conditions change with time, and this evaluation, along with the funds allocated to cover the associated expenses should be reviewed and revised periodically as the Department's needs evolve. Unanticipated expenses can develop for a number of reasons including accelerated use or changes in use patterns, accident, or deferred general maintenance. Such reviews should include updating baseline costs and dates for the components or assemblies identified in this study.

Costs are calculated at 2019 levels and escalated at the following presumed annual rate of inflation:

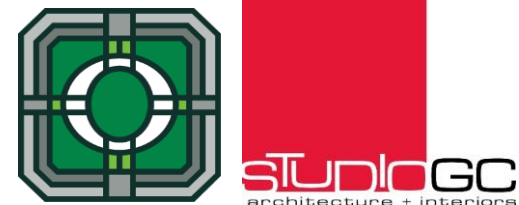
6.50% per annum

This report is broken up into different categories. The first three are organized by category with like expenses grouped together. The worksheets also covers Mechanical expenses, Electrical expenses, and Plumbing expenses. The last worksheet is organized by the computed year of expense (Budget Year).

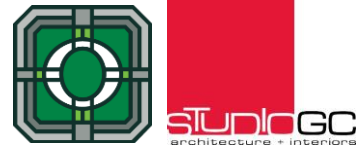
Repair/replacement work items do not include A/E Design Fees in the cost.

Total Combined Facilities

2020	\$145,941
2038	\$110,446
2048	\$123,365
Total:	\$379,752



NAME: SARATOGA PARK
ADDRESS: 9704 161st Place, Orland Park, IL, USA
PARK TYPE: Neighborhood
EVALUATION YEAR: 2019



PARK MAP:



PARK DATA:

Year Renovated:	2005
Park Age:	14
Total Acreage:	2
Total Parking Space:	0

Amenities:

Playground Equip: Little Tykes
 Bocce Ball
 Pavilion
 Bike/Walking Path

SECURITY COMMENTS:

Park security is as to be expected for this size facility. See a few specific areas of note and one concern:
 - Great visibility from public ways
 - Security lighting should be considered if law enforcement has concerns.

Score **3.00**

ACCESSIBILITY COMMENTS

Park was constructed prior to 2010 and as such is not required to be compliant to the ADA regulations.
 - Play areas are not accessible.
 - Pavilion is too small to provide ADA required clearances.
 - Bocce Ball courts are not accessible.

Score **2.00**

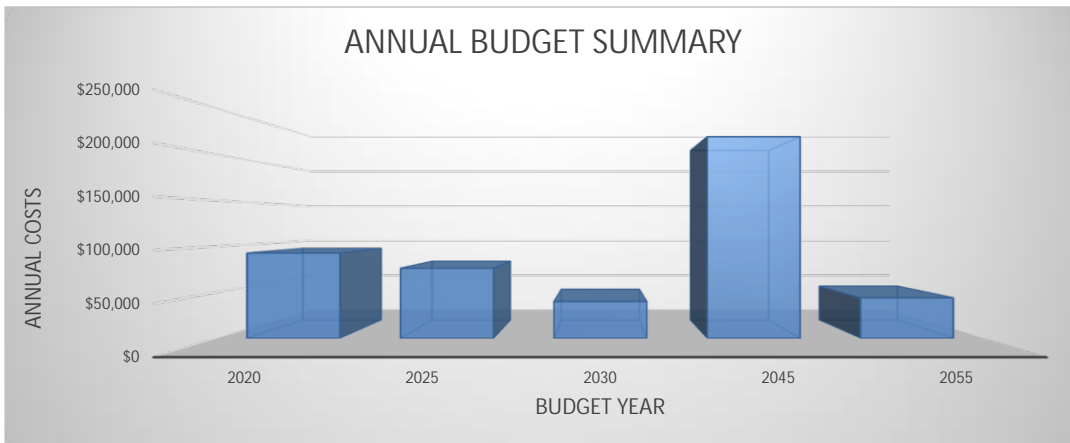
GENERAL CONDITION COMMENTS

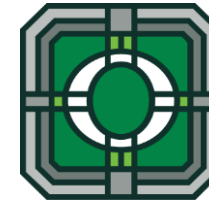
Park is in good condition given its age.
 - Bocce ball courts are deteriorated
 - Concrete walks and furnishings are in appropriate condition for their age.
 - Pavilion requires a new coat of paint and some repair trim work.
 - Brick pavers should be removed during concrete lifecycle repair or earlier

Score **3.00**

Score Average **2.67**

ANNUAL COST GRAPH:





COST BY BUDGET YEAR:

SARATOGA PARK

Budget Year	Component	Detail	Values	
			Sum of 2019 Replacement Cost	Sum of Escalated Budget
2020	PARK AMENITIES	Benches	\$12,000.00	\$12,780.00
		Trash/Recycling	\$5,000.00	\$5,325.00
	Play Component	Ground Equipment	\$3,600.00	\$3,834.00
		Mulch	\$14,500.00	\$15,442.50
		Elevated Structures	\$52,000.00	\$55,380.00
	RECREATION COMPONENTS	Bocce Ball Court	\$0.00	\$0.00
2020 Total			\$87,100.00	\$92,761.50
2025	SITE COMPONENTS	Concrete Patios	\$52,200.00	\$76,167.23
2025 Total			\$52,200.00	\$76,167.23
2030	PARK AMENITIES	Pavilion	\$20,000.00	\$39,983.03
2030 Total			\$20,000.00	\$39,983.03
2045	SITE COMPONENTS	Concrete Walks	\$32,775.00	\$168,512.65
	Play Component	Edge Restraint	\$9,880.00	\$50,798.02
2045 Total			\$42,655.00	\$219,310.66
2055	SITE COMPONENTS	Landscaping	\$4,560.00	\$44,009.93
2055 Total			\$4,560.00	\$44,009.93
Grand Total			\$206,515.00	\$472,232.35

SARATOGA PARK		9704 161st Place, Orland Park, IL, USA				General Conditions			Evaluated Condition			Estimated Cost Data - 2019						Comments	
Description/Life Expectancy		Task	Installed Date	Service Life	Anticipated Replacement Date	Security (1-5)	General (1-5)	Accessibility (1-5)	Evaluation Date	Life Expectancy Modifier	Life Expectancy Beyond Evaluation (years remaining)	Budget Year	Qty	Units	Prorate	Unit Cost	2019 Replacement Cost		Escalated Budget
Component	Detail		(year)	(years)	(year)	(0 is lowest)	(0 is lowest)	(0 is lowest)	(year)	%	(0 is lowest)						(As of Evaluation date)		
SITE COMPONENTS						3													
Site Components	Concrete Walks		2005	40	2045		3	3	2019	0%	0	2045	6,555	sf		\$5.00	\$32,775	\$168,513	
Site Components	Concrete Patios		2005	20	2025		3	3	2019	0%	0	2025	2,900	sf		\$18.00	\$52,200	\$76,167	
Site Components	Landscaping		2005	50	2055		3		2019	0%	0	2055	57,000	sf		\$0.08	\$4,560	\$44,010	
PLAY COMPONENTS																			
Play Component	Elevated Structures		2005	15	2020		3	2	2019	0%	0	2020	1	each		\$52,000.00	\$52,000	\$55,380	See Accessibility Chart
Play Component	Ground Equipment		2005	15	2020		3	2	2019	0%	0	2020	3	each		\$1,200.00	\$3,600	\$3,834	See Accessibility Chart
Play Component	Mulch		2010	10	2020		3	1	2019	0%	0	2020	2,900	sf		\$5.00	\$14,500	\$15,443	
Play Component	Edge Restraint		2005	40	2045		4		2019	0%	0	2045	260	lf		\$38.00	\$9,880	\$50,798	Plastic Edging
PARK AMENITIES																			
Park Amenities	Benches		2005	10	2015		3	3	2019	50%	5	2020	12	each		\$1,000.00	\$12,000	\$12,780	
Park Amenities	Trash/Recycling		2005	10	2015		3		2019	50%	5	2020	2	each		\$2,500.00	\$5,000	\$5,325	
Park Amenities	Pavilion		2005	25	2030		3	1	2019	0%	0	2030	200	sf		\$100.00	\$20,000	\$39,983	
RECREATION COMPONENTS																			
Recreation Components	Bocce Ball Court		2005	15	2020		2	1	2019	0%	0	2020	1	each		\$0.00	\$0	\$0	
						3.00	3.00	2.00							\$206,515	\$472,232			

NOTES

Evaluation of building conditions focused on the elements likely to be included in the budget for items expected to require replacement or renovation within the next 10 to 15 years. Equipment, materials, or assemblies that are nominal in cost are not included. This is therefore not a comprehensive list but does identify major expenses that are likely to be incurred in the foreseeable future.

Conditions change with time, and this evaluation, along with the funds allocated to cover the associated expenses should be reviewed and revised periodically as the department's needs evolve. Unanticipated expenses can develop for a number of reasons including accelerated use or changes in use patterns, accident, or deferred general maintenance. Such reviews should include updating baseline costs and dates for the components or assemblies identified in this study.

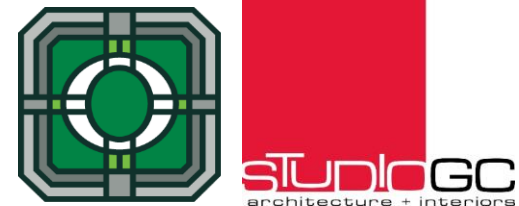
Costs are calculated at 2019 levels and escalated at the following presumed annual rate of inflation:

6.50% per annum

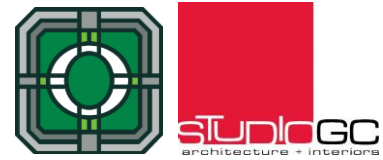
This report is broken up into different categories. The first three are organized by category with like expenses grouped together. The worksheets also covers Mechanical expenses, Electrical expenses, and Plumbing expenses. The last worksheet is organized by the computed year of expense (Budget Year).

Repair/replacement work items do not include A/E Design Fees in the cost.

Total Combined Facilities	
2020	\$92,762
2025	\$76,167
2030	\$39,983
2045	\$219,311
2055	\$44,010
Total:	\$472,232



NAME: SCHUSSLER PARK
ADDRESS: 14609 Poplar Rd, Orland Park, IL, USA
PARK TYPE: Community
EVALUATION YEAR: 2019



PARK MAP:



PARK DATA:

Year Renovated:	1996
Park Age:	23
Total Acreage:	21
Total Parking Spaces:	115

Amenities:

Playground Equip:	Gametime
Baseball Field/ Softball	1
Drinking Fountain	
Pavilion	
Soccer Fields	3
Tennis Courts	4
Fishing	
Handicap Swing	
Picnic grills	
Sled hill	

SECURITY COMMENTS:

Score **3.50**

- Park security is as to be expected for this size facility. See a few specific areas of note and one concern:
- Great visibility from public ways
 - There appears to be general and security lighting thus bringing the score up a bit.
 - Security lighting should be considered if law enforcement has concerns.

ACCESSIBILITY COMMENTS

Score **1.23**

- The park was constructed prior to the 2010 Accessibility Code revision. There are a few items of note:
- The ramp to the elevated playground ends in a step.
 - Most of the fields have no accessible path to them.
 - Parking lot is beyond it's useful life
 - All fields are past their useful life.

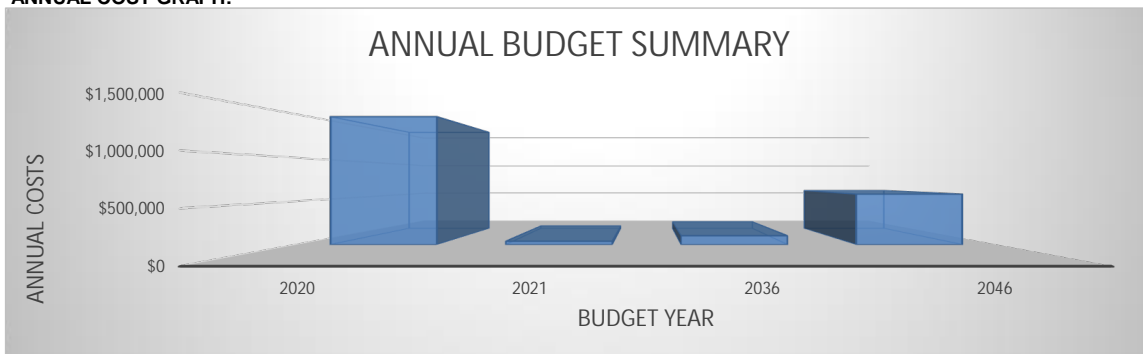
GENERAL CONDITION COMMENTS

Score **1.89**

- The park has reached the end of it's useful life.
- The play equipment is deteriorated and needs significant repair.
 - The fields and courts are deteriorated beyond repair. There appears to be grading issues that result in standing water.
 - All asphalt surfaces have exceeded their life cycle and are showing significant deterioration and require replacement.

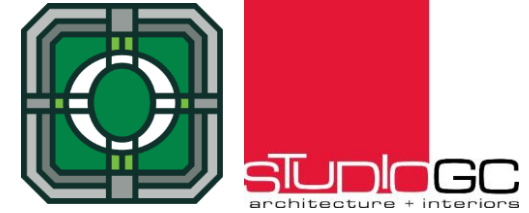
Score Average **2.21**

ANNUAL COST GRAPH:



COST BY BUDGET YEAR:

SCHUSSLER PARK



Budget Year	Component	Detail	Values	
			Sum of 2019 Replacement Cost	Sum of Escalated Budget
2020	SITE COMPONENTS	Concrete Patios	\$34,200.00	\$36,423.00
		Asphalt Replacement	\$270,200.00	\$287,763.00
	PARK AMENITIES	Benches	\$10,000.00	\$10,650.00
		Pavilion	\$76,000.00	\$80,940.00
		Park Lighting (Sports lighting)	\$390,000.00	\$415,350.00
		Trash/Recycling	\$4,000.00	\$4,260.00
		Bike Racks/Systems	\$6,500.00	\$6,922.50
		Drinking Fountains	\$3,000.00	\$3,195.00
	Play Component	Elevated Structures (2)	\$50,000.00	\$53,250.00
		Ground Equipment	\$15,000.00	\$15,975.00
		Mulch	\$49,500.00	\$52,717.50
	RECREATION COMPONENTS	Basketball Courts	\$67,500.00	\$71,887.50
		Soccer Goals (competition)	\$14,000.00	\$14,910.00
Tennis Court (4)		\$392,000.00	\$417,480.00	
2020 Total			\$1,381,900.00	\$1,471,723.50
2021	SITE COMPONENTS	Asphalt - Sealcoat	\$32,200.00	\$36,522.05
		Parking Spaces/Lot (Paint)	\$2,300.00	\$2,608.72
2021 Total		\$34,500.00	\$39,130.76	

Description/Life Expectancy						General Conditions			Evaluated Condition			Estimated Cost Data - 2019							
Component	Detail	Task	Installed Date	Service Life	Anticipated Replacement Date	Security (1-5)	General (1-5)	Accessibility (1-5)	Evaluation Date	Life Expectancy Modifier	Life Expectancy Beyond Evaluation (years remaining)	Budget Year	Qty	Units	Prorate	Unit Cost	2019 Replacement Cost	Escalated Budget	Comments
			(year)	(years)	(year)	(0 is lowest)	(0 is lowest)	(0 is lowest)	(year)	%	(0 is lowest)						(As of Evaluation date)		
SITE COMPONENTS																			
						3													
Site Components	Asphalt - Sealcoat		2017	3	2020		2		2019	30%	1	2021	32,200	sf		\$1.00	\$32,200	\$36,522	
Site Components	Asphalt Replacement		1996	15	2011		1		2019	60%	9	2020	38,600	sf		\$7.00	\$270,200	\$287,763	
Site Components	Concrete Walks		1996	40	2036		1	1	2019	0%	0	2036	4,095	sf		\$5.00	\$20,475	\$59,727	
Site Components	Concrete Patios		1996	20	2016		2	1	2019	20%	4	2020	1,900	sf		\$18.00	\$34,200	\$36,423	
Site Components	Landscaping		1996	50	2046		2		2019	0%	0	2046	670,000	sf		\$0.08	\$53,600	\$293,497	
Site Components	Parking Spaces/Lot (Paint)		2017	4	2021		1		2019	0%	0	2021	115	each		\$20.00	\$2,300	\$2,609	2 Handicapped
PLAY COMPONENTS																			
						3													
Play Component	Elevated Structures (2)		1996	15	2011		2	1	2019	60%	9	2020	2	each		\$25,000.00	\$50,000	\$53,250	See Accessibility Chart
Play Component	Ground Equipment		1996	15	2011		2	1	2019	60%	9	2020	6	each		\$2,500.00	\$15,000	\$15,975	See Accessibility Chart
Play Component	Mulch		2010	10	2020		3	1	2019	0%	0	2020	9,900	sf		\$5.00	\$49,500	\$52,718	
Play Component	Edge Restraint		1996	40	2036		3		2019	0%	0	2036	387	lf		\$38.00	\$14,706	\$42,898	Plastic Edging
PARK AMENITIES																			
						4													
Park Amenities	Park Lighting (Sports lighting)		1996	20	2016		3		2019	20%	4	2020	13	each		\$30,000.00	\$390,000	\$415,350	
Park Amenities	Benches		1996	10	2006		2	1	2019	140%	14	2020	10	each		\$1,000.00	\$10,000	\$10,650	
Park Amenities	Trash/Recycling		1996	10	2006		2	1	2019	140%	14	2020	10	each		\$400.00	\$4,000	\$4,260	
Park Amenities	Bike Racks/Systems		1996	10	2006				2019	140%	14	2020	1	each		\$6,500.00	\$6,500	\$6,923	
Park Amenities	Drinking Fountains		1996	15	2011		3	2	2019	60%	9	2020	1	each		\$3,000.00	\$3,000	\$3,195	
Park Amenities	Pavilion		1996	24	2020		2	3	2019	0%	0	2020	760	sf		\$100.00	\$76,000	\$80,940	
RECREATION COMPONENTS																			
						4													
Recreation Components	Basketball Courts		1996	20	2016		1	1	2019	20%	4	2020	0.5	each		\$135,000.00	\$67,500	\$71,888	
Recreation Components	Baseball Field		1996	50	2046		2	1	2019	0%	0	2046	1.5	each		\$35,000.00	\$52,500	\$287,474	
Recreation Components	Tennis Court (4)		1996	20	2016		1	1	2019	20%	4	2020	4	each		\$98,000.00	\$392,000	\$417,480	
Recreation Components	Soccer Goals (competition)		1996	5	2001		1	1	2019	375%	19	2020	2	each		\$7,000.00	\$14,000	\$14,910	

NOTES

Evaluation of building conditions focused on the elements likely to be included in the budget for items expected to require replacement or renovation within the next 10 to 15 years. Equipment, materials, or assemblies that are nominal in cost are not included. This is therefore not a comprehensive list but does identify major expenses that are likely to be incurred in the foreseeable future.

Conditions change with time, and this evaluation, along with the funds allocated to cover the associated expenses should be reviewed and revised periodically as the Department's needs evolve. Unanticipated expenses can develop for a number of reasons including accelerated use or changes in use patterns, accident, or deferred general maintenance. Such reviews should include updating baseline costs and dates for the components or assemblies identified in this study.

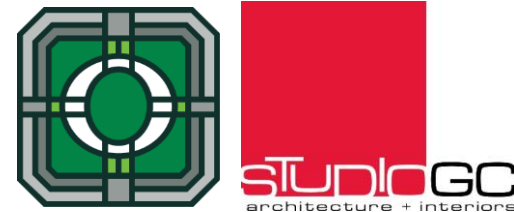
Costs are calculated at 2019 levels and escalated at the following presumed annual rate of inflation:

6.50% per annum

This report is broken up into different categories. The first three are organized by category with like expenses grouped together. The worksheets also covers Mechanical expenses, Electrical expenses, and Plumbing expenses. The last worksheet is organized by the computed year of expense (Budget Year).

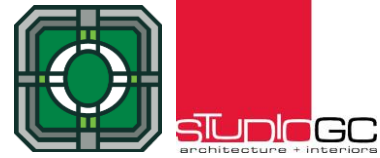
Repair/replacement work items do not include A/E Design Fees in the cost.

Total Combined Facilities	
2020	\$1,471,724
2021	\$39,131
2036	\$102,625
2046	\$580,971
Total:	\$2,194,450



NOTES

NAME: SPRING CREEK ESTATES PARK
ADDRESS: 11240 Poplar Creek Ln, Orland Park, IL, USA
PARK TYPE: Neighborhood
EVALUATION YEAR: 2019



PARK MAP:



PARK DATA:

Year Renovated:	1999
Park Age:	20
Total Acreage:	5.1
Total Parking Spaces:	0

Amenities:

Playground Equip: Miracle
 Basketball Court
 Bike/ Walking Path
 Drinking Fountain
 Fishing
 Pavilion
 Picnic Grills

SECURITY COMMENTS:

Score **3.00**

Park security is as to be expected for this size facility. See a few specific areas of note and one concern:
 - Great visibility from public ways
 - Security lighting should be considered if law enforcement has concerns.

ACCESSIBILITY COMMENTS

Score **1.83**

The park and amenities were constructed prior to the 2010 ADA regulations.
 - Play areas are not accessible.
 - Asphalt walks are not accessible due to deterioration
 - Playground equipment will require additional evaluation to determine ADA compliance

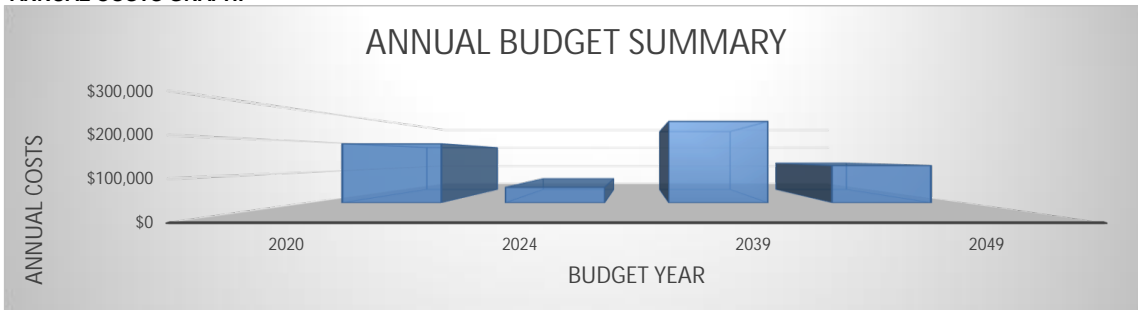
GENERAL CONDITION COMMENTS

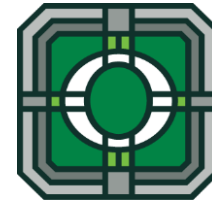
Score **2.17**

Park is in generally good shape for the age but there are some areas of concern:
 - Asphalt walks are significantly deteriorated.
 - Play equipment have deteriorated finishes.
 - Basketball Court is ponding and this is deteriorating the surface and finishes, the goal needs to be replaced and is leaning.

Score Average **2.33**

ANNUAL COSTS GRAPH:





COST BY BUDGET YEAR:

SPRING CREEK ESTATES PARK

Budget Year	Component	Detail	Values	
			Sum of 2019 Replacement Cost	Sum of Escalated Budget
2020	PARK AMENITIES	Benches	\$3,000.00	\$3,195.00
		Trash/Recycling	\$800.00	\$852.00
		Bike Racks/Systems	\$400.00	\$426.00
	Play Component	Elevated Structures (2)	\$50,000.00	\$53,250.00
		Ground Equipment	\$22,500.00	\$23,962.50
		Mulch	\$47,000.00	\$50,055.00
	RECREATION COMPON	Basketball Courts	\$57,500.00	\$61,237.50
2020 Total			\$181,200.00	\$192,978.00
2024	SITE COMPONENTS	Concrete Patios	\$4,968.00	\$6,806.59
	PARK AMENITIES	Pavilion	\$29,000.00	\$39,732.51
		Drinking Fountains	\$3,000.00	\$4,110.26
2024 Total			\$36,968.00	\$50,649.36
2039	SITE COMPONENTS	Concrete Walks	\$53,125.00	\$187,193.64
	Play Component	Edge Restraint	\$22,420.00	\$79,000.12
2039 Total			\$75,545.00	\$266,193.77
2049	SITE COMPONENTS	Landscaping	\$18,400.00	\$121,704.34
2049 Total			\$18,400.00	\$121,704.34
Grand Total			\$312,113.00	\$631,525.47

Description/Life Expectancy		Task	Installed Date	Service Life	Anticipated Replacement Date	General Conditions			Evaluated Condition			Estimated Cost Data - 2019						Comments	
Component	Detail		(year)	(years)	(year)	Security (1-5)	General (1-5)	Accessibility (1-5)	Evaluation Date	Life Expectancy Modifier	Life Expectancy Beyond Evaluation (years remaining)	Budget Year	Qty	Units	Prorate	Unit Cost	2019 Replacement Cost		Escalated Budget
						(0 is lowest)	(0 is lowest)	(0 is lowest)	(year)	%	(0 is lowest)						(As of Evaluation date)		
SITE COMPONENTS						3													
Site Components	Concrete Walks		1999	40	2039		2	1	2019	0%	0	2039	10,625	sf		\$5.00	\$53,125	\$187,194	
Site Components	Concrete Patios		1999	20	2019				2019	24%	5	2024	276	sf		\$18.00	\$4,968	\$6,807	
Site Components	Landscaping		1999	50	2049				2019	0%	0	2049	230,000	sf		\$0.08	\$18,400	\$121,704	
PLAY COMPONENTS																			
Play Component	Elevated Structures (2)		1999	15	2014				2019	40%	6	2020	2	each		\$25,000.00	\$50,000	\$53,250	See Accessibility Chart
Play Component	Ground Equipment		1999	15	2014		2	3	2019	40%	6	2020	9	each		\$2,500.00	\$22,500	\$23,963	See Accessibility Chart
Play Component	Mulch		2010	10	2020		2	2	2019	0%	0	2020	9,400	sf		\$5.00	\$47,000	\$50,055	
Play Component	Edge Restraint		1999	40	2039				2019	0%	0	2039	590	lf		\$38.00	\$22,420	\$79,000	Plastic Edging
PARK AMENITIES																			
Park Amenities	Benches		1999	10	2009		3	1	2019	110%	11	2020	3	each		\$1,000.00	\$3,000	\$3,195	
Park Amenities	Trash/Recycling		1999	10	2009				2019	110%	11	2020	2	each		\$400.00	\$800	\$852	
Park Amenities	Bike Racks/Systems		1999	10	2009				2019	110%	11	2020	1	each		\$400.00	\$400	\$426	
Park Amenities	Drinking Fountains		1999	15	2014				2019	65%	10	2024	1	each		\$3,000.00	\$3,000	\$4,110	
Park Amenities	Pavilion		1999	25	2024		2	3	2019	0%	0	2024	290	sf		\$100.00	\$29,000	\$39,733	
RECREATION COMPONENTS																			
Recreation Components	Basketball Courts		1999	20	2019		2	1	2019	5%	1	2020	0.5	each		\$115,000.00	\$57,500	\$61,238	
						3.00	2.17	1.83							\$312,113	\$631,525			

NOTES

Evaluation of building conditions focused on the elements likely to be included in the budget for items expected to require replacement or renovation within the next 10 to 15 years. Equipment, materials, or assemblies that are nominal in cost are not included. This is therefore not a comprehensive list but does identify major expenses that are likely to be incurred in the foreseeable future.

Conditions change with time, and this evaluation, along with the funds allocated to cover the associated expenses should be reviewed and revised periodically as the Department's needs evolve. Unanticipated expenses can develop for a number of reasons including accelerated use or changes in use patterns, accident, or deferred general maintenance. Such reviews should include updating baseline costs and dates for the components or assemblies identified in this study.

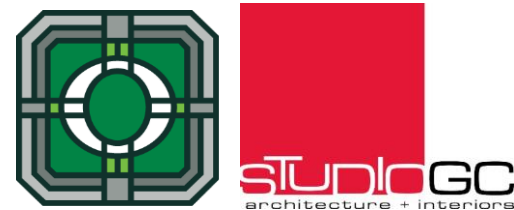
Costs are calculated at 2019 levels and escalated at the following presumed annual rate of inflation:

6.50% per annum

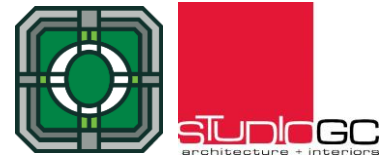
This report is broken up into different categories. The first three are organized by category with like expenses grouped together. The worksheets also covers Mechanical expenses, Electrical expenses, and Plumbing expenses. The last worksheet is organized by the computed year of expense (Budget Year).

Repair/replacement work items do not include A/E Design Fees in the cost.

Total Combined Facilities	
2020	\$192,978
2024	\$50,649
2039	\$266,194
2049	\$121,704
Total:	\$631,525



NAME: SUNNY PINE PARK
ADDRESS: 13701 88th Avenue, Orland Park
PARK TYPE: Neighborhood
EVALUATION YEAR: 2019



PARK MAP:



PARK DATA:

Year Renovated:	2012
Park Age:	7
Total Acreage:	6.1
Total Parking Spaces:	0

Amenities:

Playground Equip: Gametime
 Basketball Court
 Fishing

SECURITY COMMENTS:

Score **3.00**

Park security is as to be expected for this size facility. See a few specific areas of note and one concern:
 - Great visibility from public ways
 - Security lighting should be considered if law enforcement has concerns.

ACCESSIBILITY COMMENTS

Score **2.33**

The play equipment appears to be designed in accordance to current ADA standards.
 - The basketball court is not on an accessible path.
 - The walkway to the playground has no accessible entrance into the play area.

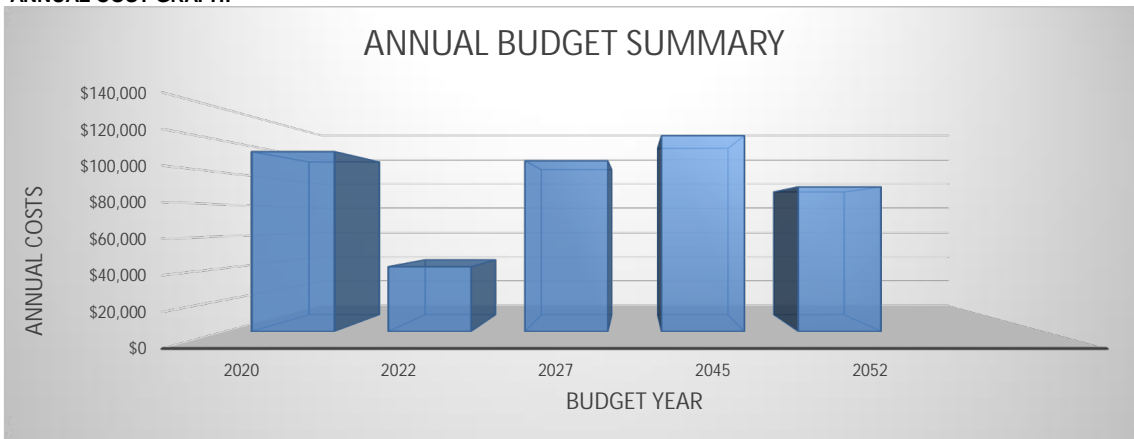
GENERAL CONDITION COMMENTS

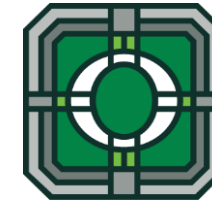
Score **3.63**

The park is generally in good condition. The play equipment was erected in 2012. The remainder of the park appears to be original.
 - Asphalt walks are in need of replacement
 - Basketball court is in need of replacement, it is ponding water and the surface finish is gone and edges are crumbling

Score Average **2.99**

ANNUAL COST GRAPH:





COST BY BUDGET YEAR:

SUNNY PINE PARK

Budget Year	Component	Detail	Values	
			Sum of 2019 Replacement Cost	Sum of Escalated Budget
2020	RECREATION COMPONENTS	Basketball Courts	\$57,500.00	\$61,237.50
		Fencing	\$48,875.00	\$52,051.88
2020 Total			\$106,375.00	\$113,289.38
2022	PARK AMENITIES	Benches	\$6,000.00	\$7,247.70
		Trash/Recycling	\$800.00	\$966.36
	Play Component	Mulch	\$27,000.00	\$32,614.64
2022 Total			\$33,800.00	\$40,828.70
2027	Play Component	Elevated Structures (2)	\$55,000.00	\$91,024.76
		Ground Equipment	\$10,000.00	\$16,549.96
2027 Total			\$65,000.00	\$107,574.72
2045	SITE COMPONENTS	Concrete Walks	\$19,000.00	\$97,688.49
		Landscaping	\$5,000.00	\$25,707.50
2045 Total			\$24,000.00	\$123,395.99
2052	Play Component	Edge Restraint	\$11,400.00	\$91,083.96
2052 Total			\$11,400.00	\$91,083.96
Grand Total			\$240,575.00	\$476,172.74

SUNNY PINE PARK		13701 88th Avenue, Orland Park				General Conditions			Evaluated Condition			Estimated Cost Data - 2019						Comments	
Description/Life Expectancy		Installed Date	Service Life	Anticipated Replacement Date	Security (1-5)	General (1-5)	Accessibility (1-5)	Evaluation Date	Life Expectancy Modifier	Life Expectancy Beyond Evaluation (years remaining)	Budget Year	Qty	Units	Prorate	Unit Cost	2019 Replacement Cost	Escalated Budget		
Component	Detail	Task	(year)	(years)	(year)	(0 is lowest)	(0 is lowest)	(0 is lowest)	(year)	%	(0 is lowest)					(As of Evaluation date)			
SITE COMPONENTS						3													
Site Components	Concrete Walks		2005	40	2045		2		2019	0%	0	2045	3,800	sf		\$5.00	\$19,000	\$97,688	
Site Components	Landscaping		2005	40	2045				2019	0%	0	2045	1	ls		\$5,000.00	\$5,000	\$25,707	
PLAY COMPONENTS						3													
Play Component	Elevated Structures (2)		2012	15	2027		5	4	2019	0%	0	2027	1	each		\$55,000.00	\$55,000	\$91,025	See Accessibility Chart
Play Component	Ground Equipment		2012	15	2027		5	4	2019	0%	0	2027	4	each		\$2,500.00	\$10,000	\$16,550	See Accessibility Chart
Play Component	Mulch		2012	10	2022		3	1	2019	0%	0	2022	5,400	sf		\$5.00	\$27,000	\$32,615	
Play Component	Edge Restraint		2012	40	2052		5		2019	0%	0	2052	300	lf		\$38.00	\$11,400	\$91,084	Plastic Edging
PARK AMENITIES						3													
Park Amenities	Benches		2012	10	2022		3	1	2019	0%	0	2022	6	each		\$1,000.00	\$6,000	\$7,248	
Park Amenities	Trash/Recycling		2012	10	2022		3	3	2019	0%	0	2022	2	each		\$400.00	\$800	\$966	
RECREATION COMPONENTS						3													
Recreation Components	Basketball Courts		2000	20	2020		3	1	2019	0%	0	2020	0.5	each		\$115,000.00	\$57,500	\$61,238	
Recreation Components	Fencing		2012	8	2020				2019	0%	0	2020	391	lf		\$125.00	\$48,875	\$52,052	
						3.00	3.63	2.33							\$191,700	\$424,121			

NOTES

Evaluation of building conditions focused on the elements likely to be included in the budget for items expected to require replacement or renovation within the next 10 to 15 years. Equipment, materials, or assemblies that are nominal in cost are not included. This is therefore not a comprehensive list but does identify major expenses that are likely to be incurred in the foreseeable future.

Conditions change with time, and this evaluation, along with the funds allocated to cover the associated expenses should be reviewed and revised periodically as the Department's needs evolve. Unanticipated expenses can develop for a number of reasons including accelerated use or changes in use patterns, accident, or deferred general maintenance. Such reviews should include updating baseline costs and dates for the components or assemblies identified in this study.

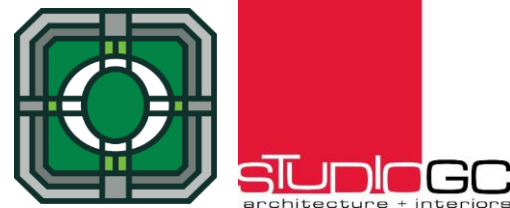
Costs are calculated at 2019 levels and escalated at the following presumed annual rate of inflation:

6.50% per annum

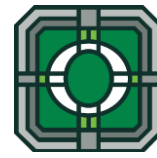
This report is broken up into different categories. The first three are organized by category with like expenses grouped together. The worksheets also covers Mechanical expenses, Electrical expenses, and Plumbing expenses. The last worksheet is organized by the computed year of expense (Budget Year).

Repair/replacement work items do not include A/E Design Fees in the cost.

Total Combined Facilities	
2020	\$113,289
2022	\$40,829
2027	\$107,575
2045	\$123,396
2052	\$91,084
Total:	\$476,173



NAME: TAMPIER-MCGINNIS PARK
ADDRESS: 13825 110th Ave, Orland Park, IL, USA
PARK TYPE: Mini
EVALUATION YEAR: 2019



PARK MAP:



PARK DATA:

Year Renovated:	2001
Park Age:	18
Total Acreage:	3
Total Parking Spaces:	

Amenities:

Playground Equip: Gametime

SECURITY COMMENTS:

Score 3.00

- Park security is as to be expected for this size facility. See a few specific areas of note and one concern:
- Great visibility from public ways
 - Security lighting should be considered if law enforcement has concerns.
 - Safety barrier should be added as the park is within 100 feet of the roadway.

ACCESSIBILITY COMMENTS

Score 2.83

- The park was constructed prior to the 2010 Accessibility Code revision. There are a few items of note:
- The path to the fiber surface is not accessible.
 - Sidewalks provide a good level of accessibility and are generally free from heaving.

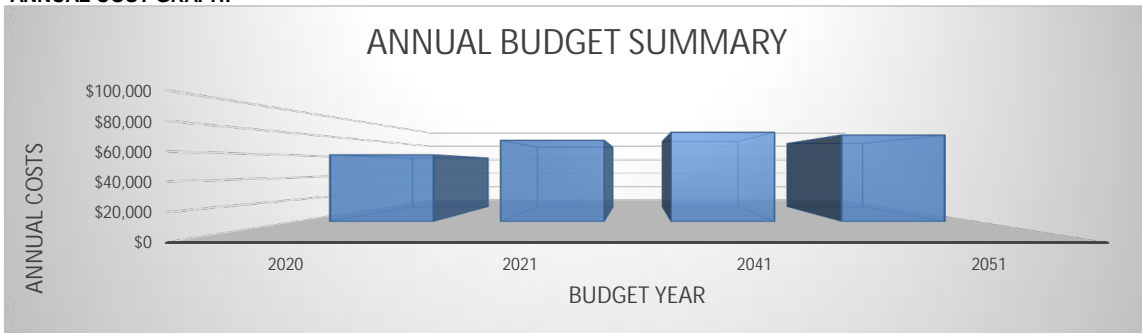
GENERAL CONDITION COMMENTS

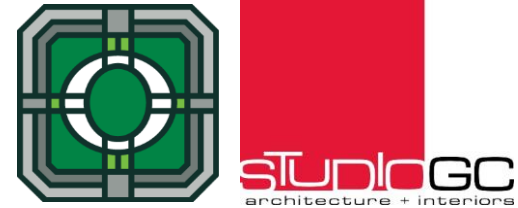
Score 2.86

- The park is in exceptional condition given it's age.
- Much of the play equipment has aged well and has only minimal deterioration requiring spot repair.

Score Average 2.90

ANNUAL COST GRAPH:





COST BY BUDGET YEAR:

TAMPIER-MCGINNIS PARK

Budget Year	Component	Detail	Values	
			Sum of 2019 Replacement Cost	Sum of Escalated Budget
2020	PARK AMENITIES	Benches	\$3,000.00	\$3,195.00
		Trash/Recycling	\$800.00	\$852.00
		Bike Racks/Systems	\$2,000.00	\$2,130.00
		Play Component	Mulch	\$51,000.00
	2020 Total			\$56,800.00
2021	Play Component	Elevated Structures (2)	\$50,000.00	\$56,711.25
		Ground Equipment	\$15,000.00	\$17,013.38
2021 Total			\$65,000.00	\$73,724.63
2041	SITE COMPONENTS	Concrete Walks	\$4,675.00	\$18,684.13
	Play Component	Edge Restraint	\$15,580.00	\$62,267.13
2041 Total			\$20,255.00	\$80,951.26
2051	SITE COMPONENTS	Landscaping	\$10,454.40	\$78,430.78
2051 Total			\$10,454.40	\$78,430.78
Grand Total			\$152,509.40	\$293,598.67

Description/Life Expectancy						General Conditions			Evaluated Condition			Estimated Cost Data - 2019								
Component	Detail	Task	Installed Date	Service Life	Anticipated Replacement Date	Security (1-5)	General (1-5)	Accessibility (1-5)	Evaluation Date	Life Expectancy Modifier	Life Expectancy Beyond Evaluation (years remaining)	Budget Year	Qty	Units	Prorate	Unit Cost	2019 Replacement Cost	Escalated Budget	Comments	
			(year)	(years)	(year)	(0 is lowest)	(0 is lowest)	(0 is lowest)	(year)	%	(0 is lowest)						(As of Evaluation date)			
SITE COMPONENTS						3														
Site Components	Concrete Walks		2001	40	2041		5	3	2019	0%	0	2041	935	sf		\$5.00	\$4,675	\$18,684		
Site Components	Landscaping		2001	50	2051				2019	0%	0	2051	130,680	sf		\$0.08	\$10,454	\$78,431		
PLAY COMPONENTS																				
Play Component	Elevated Structures (2)		2001	15	2016		2	3	2019	28%	4	2021	2	each		\$25,000.00	\$50,000	\$56,711	See Accessibility Chart	
Play Component	Ground Equipment		2001	15	2016		2	3	2019	28%	4	2021	6	each		\$2,500.00	\$15,000	\$17,013	See Accessibility Chart	
Play Component	Mulch		2010	10	2020		3	3	2019	0%	0	2020	10,200	sf		\$5.00	\$51,000	\$54,315		
Play Component	Edge Restraint		2001	40	2041		4		2019	0%	0	2041	410	lf		\$38.00	\$15,580	\$62,267	Plastic Edging	
PARK AMENITIES																				
Park Amenities	Benches		2001	10	2011		2	3	2019	90%	9	2020	3	each		\$1,000.00	\$3,000	\$3,195		
Park Amenities	Trash/Recycling		2001	10	2011		2	2	2019	90%	9	2020	2	each		\$400.00	\$800	\$852		
Park Amenities	Bike Racks/Systems		2001	10	2011				2019	90%	9	2020	5	each		\$400.00	\$2,000	\$2,130		
RECREATION COMPONENTS																				
						3.00	2.86	2.83										\$152,509	\$293,599	

NOTES

Evaluation of conditions focused on the elements likely to be included in the budget for items expected to require replacement or renovation within the next 10 to 15 years. Equipment, materials, or assemblies that are nominal in cost are not included. This is therefore not a comprehensive list but does identify major expenses that are likely to be incurred in the foreseeable future.

Conditions change with time, and this evaluation, along with the funds allocated to cover the associated expenses should be reviewed and revised periodically as the Department's needs evolve. Unanticipated expenses can develop for a number of reasons including accelerated use or changes in use patterns, accident, or deferred general maintenance. Such reviews should include updating baseline costs and dates for the components or assemblies identified in this study.

Costs are calculated at 2019 levels and escalated at the following presumed annual rate of inflation:

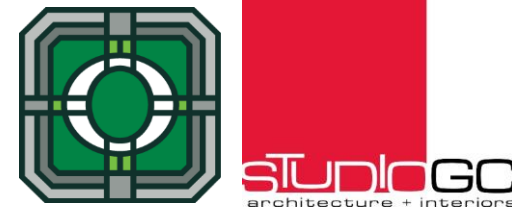
6.50% per annum

This report is broken up into different categories. The first three are organized by category with like expenses grouped together. The worksheets also covers Mechanical expenses, Electrical expenses, and Plumbing expenses. The last worksheet is organized by the computed year of expense (Budget Year).

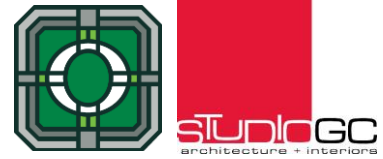
Repair/replacement work items do not include A/E Design Fees in the cost.

Total Combined Facilities

2020	\$60,492
2021	\$73,725
2041	\$80,951
2051	\$78,431
Total:	\$293,599



NAME: TREETOP PARK
ADDRESS: 15400 Treetop Drive, Orland Park
PARK TYPE: Neighborhood
EVALUATION YEAR: 2019



PARK MAP:



PARK DATA:

Year Renovated:	1998
Park Age:	21
Total Acreage:	7.6
Total Parking Spaces:	32

Amenities:

- Playground Equipment
- Gametime
- Playground Equipment
- Street Hockey
- 1/2 Basketball
- Misc Paved Activities
- Pavillion

SECURITY COMMENTS:

- Park security is as to be expected for this size facility. See a few specific areas of note and one concern:
- Great visibility from public ways
 - Security lighting should be considered if law enforcement has concerns.
 - Provide a fence between playground and pond

Score **2.50**

ACCESSIBILITY COMMENTS

- Park was constructed prior to the 2010 regulations.
- Play area is not accessible per current standards.

Score **2.70**

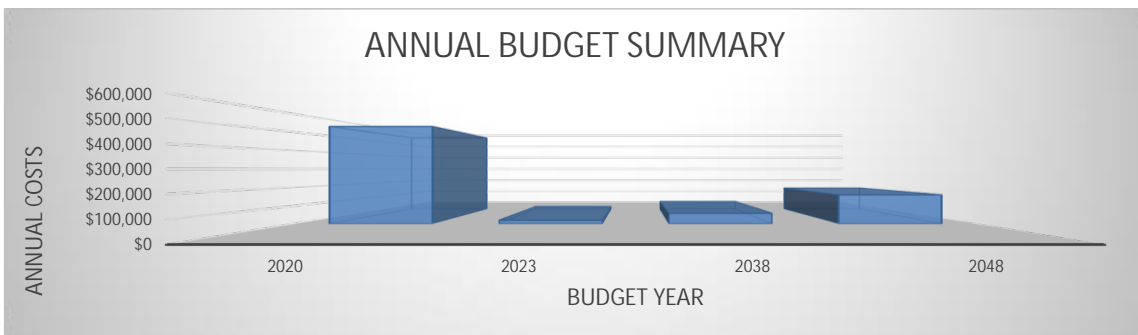
GENERAL CONDITION COMMENTS

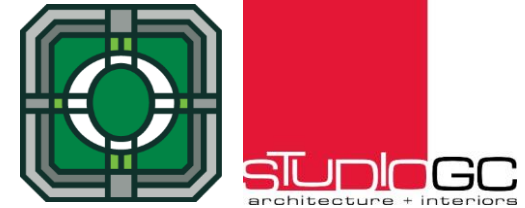
- Playground is aging as expected for the age. There are a few items of note:
- Asphalt recreational areas are significantly deteriorating.
 - Play equipment has finish deterioration.

Score **2.46**

Score Average **2.55**

ANNUAL COSTS GRAPH:





COST BY BUDGET YEAR:

TREETOP PARK

Budget Year	Component	Detail	Values		
			Sum of 2019 Replacement Cost	Sum of Escalated Budget	
2020	SITE COMPONENTS	Concrete Patios	\$10,800.00	\$11,502.00	
		Asphalt - Sealcoat	\$12,400.00	\$13,206.00	
		Asphalt Replacement		\$86,800.00	\$92,442.00
		Parking Spaces/Lot (10+1HC)		\$3,000.00	\$3,195.00
	PARK AMENITIES	Benches	\$7,000.00	\$7,455.00	
		Trash/Recycling	\$800.00	\$852.00	
	Play Component	Ground Equipment	\$4,800.00	\$5,112.00	
		Mulch	\$14,000.00	\$14,910.00	
	RECREATION COMP	Elevated Structures		\$53,000.00	\$56,445.00
		Basketball Courts	\$57,500.00	\$61,237.50	
Tennis Court		\$135,000.00	\$143,775.00		
		Roller Hockey	\$115,000.00	\$122,475.00	
2020 Total			\$500,100.00	\$532,606.50	
2023	PARK AMENITIES	Pavilion	\$15,000.00	\$19,297.00	
2023 Total			\$15,000.00	\$19,297.00	
2038	SITE COMPONENTS	Concrete Walks	\$8,950.00	\$29,611.85	
	Play Component	Edge Restraint	\$8,360.00	\$27,659.79	
2038 Total			\$17,310.00	\$57,271.64	
2048	SITE COMPONENTS	Landscaping	\$25,439.04	\$157,993.54	
2048 Total			\$25,439.04	\$157,993.54	
Grand Total			\$557,849.04	\$767,168.68	

Description/Life Expectancy						General Conditions			Evaluated Condition			Estimated Cost Data - 2019						Comments	
Component	Detail	Task	Installed Date	Service Life	Anticipated Replacement Date	Security (1-5)	General (1-5)	Accessibility (1-5)	Evaluation Date	Life Expectancy Modifier	Life Expectancy Beyond Evaluation (years remaining)	Budget Year	Qty	Units	Prorate	Unit Cost	2019 Replacement Cost		Escalated Budget
			(year)	(years)	(year)	(0 is lowest)	(0 is lowest)	(0 is lowest)	(year)	%	(0 is lowest)						(As of Evaluation date)		
SITE COMPONENTS						3													
Site Components	Asphalt - Sealcoat		2017	2	2019				2019	30%	1	2020	12,400	sf		\$1.00	\$12,400	\$13,206	
Site Components	Asphalt Replacement		1998	15	2013		3		2019	45%	7	2020	12,400	sf		\$7.00	\$86,800	\$92,442	
Site Components	Concrete Walks		1998	40	2038		3	3	2019	0%	0	2038	1,790	sf		\$5.00	\$8,950	\$29,612	
Site Components	Concrete Patios		1998	20	2018		3	3	2019	10%	2	2020	600	sf		\$18.00	\$10,800	\$11,502	
Site Components	Landscaping		1998	50	2048				2019	0%	0	2048	317,988	sf		\$0.08	\$25,439	\$157,994	
Site Components	Parking Spaces/Lot (10+1HC)		2017	2	2019		3	3	2019	30%	1	2020	30	each		\$100.00	\$3,000	\$3,195	
PLAY COMPONENTS						2													
Play Component	Elevated Structures		1998	15	2013		2	2	2019	45%	7	2020	1	each		\$53,000.00	\$53,000	\$56,445	
Play Component	Ground Equipment		1998	15	2013		2	2	2019	45%	7	2020	4	each		\$1,200.00	\$4,800	\$5,112	
Play Component	Mulch		2010	10	2020		3	2	2019	0%	0	2020	2,800	sf		\$5.00	\$14,000	\$14,910	
Play Component	Edge Restraint		1998	40	2038		4		2019	0%	0	2038	220	lf		\$38.00	\$8,360	\$27,660	
PARK AMENITIES																			
Park Amenities	Benches		1998	10	2008		3	3	2019	120%	12	2020	7	each		\$1,000.00	\$7,000	\$7,455	
Park Amenities	Trash/Recycling		1998	10	2008				2019	120%	12	2020	2	each		\$400.00	\$800	\$852	
Park Amenities	Pavilion		1998	25	2023		3	3	2019	0%	0	2023	150	sf		\$100.00	\$15,000	\$19,297	
RECREATION COMPONENTS																			
Recreation Components	Basketball Courts		1998	20	2018		1	3	2019	10%	2	2020	0.5	each		\$115,000.00	\$57,500	\$61,238	
Recreation Components	Tennis Court		1998	20	2018		1	3	2019	10%	2	2020	1	each		\$135,000.00	\$135,000	\$143,775	
Recreation Components	Roller Hockey		1998	20	2018		1		2019	10%	2	2020	1	each		\$115,000.00	\$115,000	\$122,475	
						2.50	2.46	2.70									\$442,849	\$644,694	

NOTES

Evaluation of building conditions focused on the elements likely to be included in the budget for items expected to require replacement or renovation within the next 10 to 15 years. Equipment, materials, or assemblies that are nominal in cost are not included. This is therefore not a comprehensive list but does identify major expenses that are likely to be incurred in the foreseeable future.

Conditions change with time, and this evaluation, along with the funds allocated to cover the associated expenses should be reviewed and revised periodically as the Department's needs evolve. Unanticipated expenses can develop for a number of reasons including accelerated use or changes in use patterns, accident, or deferred general maintenance. Such reviews should include updating baseline costs and dates for the components or assemblies identified in this study.

Costs are calculated at 2019 levels and escalated at the following presumed annual rate of inflation:

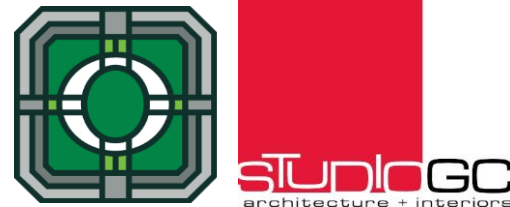
6.50% per annum

This report is broken up into different categories. The first three are organized by category with like expenses grouped together. The worksheets also covers Mechanical expenses, Electrical expenses, and Plumbing expenses. The last worksheet is organized by the computed year of expense (Budget Year).

Repair/replacement work items do not include A/E Design Fees in the cost.

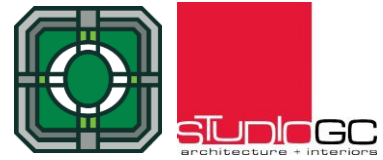
Total Combined Facilities

2020	\$532,607
2023	\$19,297
2038	\$57,272
2048	\$157,994
Total:	\$767,169



NAME: VETERANS PARK
ADDRESS: 7721 Wheeler Dr, Orland Park
PARK TYPE: Community
EVALUATION YEAR: 2019

PARK AGE:



PARK DATA:

Year Renovated:	2017
Park Age:	2
Total Acreage:	3.9
Total Parking Spaces:	17+1HC

Amenities:

Playground Equipment - Little Tykes	
Basketball Court	1
Tennis	3
Drinking Fountain	
Baseball/ Softball	7
Pavilions	
Volleyball Court	Sand
Handicap Swing	
Picnic Grill	
Roller Hockey	
Zip Line	

SECURITY COMMENTS:

- Park security is as to be expected for this size facility. See a few specific areas of note and one concern:
- Great visibility from public ways
 - Security lighting should be considered if law enforcement has concerns.

Score **3.00**

ACCESSIBILITY COMMENTS

- Most of the park is considered accessible.
- Playground is new and therefore presumed compliant with the 2010 regulations.
 - The sports fields are not on the accessible path

Score **2.67**

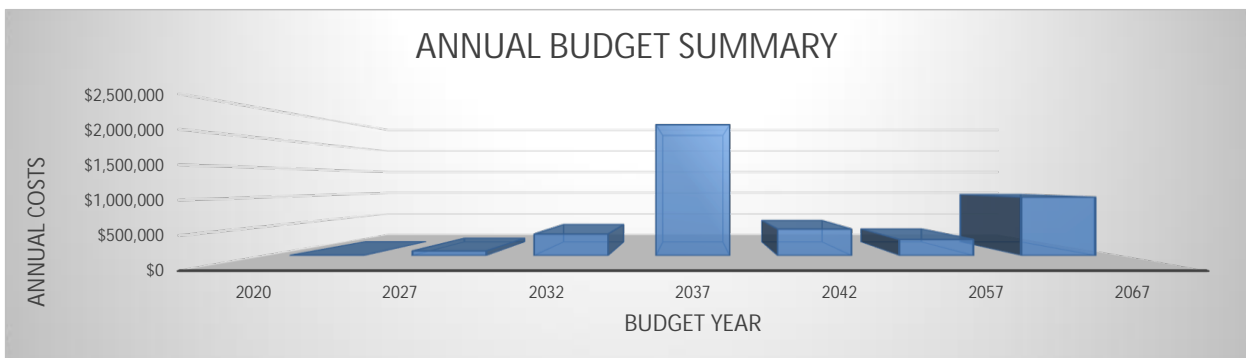
GENERAL CONDITION COMMENTS

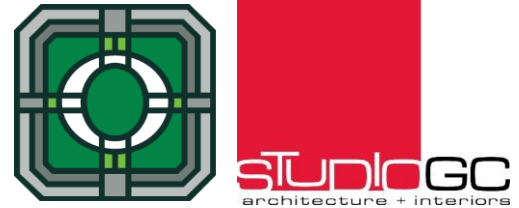
- Park is in generally very good condition. There are few items of note:
- Park is essentially new and in exceptional condition.
 - Volleyball court wood curbing is in need of replacement.
 - Baseball fencing needs to be replaced.
 - Tennis court fencing has deteriorated finishes, linework and paint is in good shape

Score **4.06**

Score Average **3.24**

ANNUAL COSTS DATA:





COST BY BUDGET YEAR:

VETERANS PARK

Budget Year	Component	Detail	Values	
			Sum of 2019 Replacement Cost	Sum of Escalated Budget
2020	SITE COMPONENTS	Asphalt - Sealcoat	\$4,900.00	\$5,218.50
		Parking Spaces/Lot (paint)	\$990.00	\$1,054.35
2020 Total			\$5,890.00	\$6,272.85
2027	PARK AMENITIES	Benches	\$15,000.00	\$24,824.94
		Trash/Recycling	\$6,000.00	\$9,929.97
		Bike Racks/Systems	\$800.00	\$1,324.00
	Play Component	Mulch	\$26,650.00	\$44,105.63
2027 Total			\$48,450.00	\$80,184.54
2032	SITE COMPONENTS	Asphalt Replacement	\$34,300.00	\$77,774.82
	PARK AMENITIES	Drinking Fountains	\$3,000.00	\$6,802.46
	Play Component	Elevated Structures (2)	\$50,000.00	\$113,374.37
		Ground Equipment	\$17,500.00	\$39,681.03
		Poured in Place	\$57,540.00	\$130,471.23
2032 Total			\$162,340.00	\$368,103.92
2037	SITE COMPONENTS	Concrete Patios	\$34,650.00	\$107,645.57
	PARK AMENITIES	Park Lighting	\$5,000.00	\$15,533.27
	RECREATION COMPONENTS	Basketball Courts	\$115,000.00	\$357,265.25
		Volley Ball Court	\$25,000.00	\$77,666.36
		Tennis Court (4)	\$540,000.00	\$1,677,593.36
2037 Total			\$719,650.00	\$2,235,703.82
2042	PARK AMENITIES	Pavilion (2 structures)	\$106,500.00	\$453,305.08
2042 Total			\$106,500.00	\$453,305.08
2057	SITE COMPONENTS	Concrete Walks	\$11,500.00	\$125,887.59
	Play Component	Edge Restraint	\$13,680.00	\$149,751.50
2057 Total			\$25,180.00	\$275,639.10
2067	SITE COMPONENTS	Landscaping	\$13,590.72	\$279,269.58
	RECREATION COMPONENTS	Baseball Field	\$35,000.00	\$719,199.24
2067 Total			\$48,590.72	\$998,468.82
Grand Total			\$1,116,600.72	\$4,417,678.13

VETERANS PARK		7721 Wheeler Dr, Orland Park				General Conditions			Evaluated Condition			Estimated Cost Data - 2019						Comments
Description/Life Expectancy		Installed Date	Service Life	Anticipated Replacement Date	Security (1-5)	General (1-5)	Accessibility (1-5)	Evaluation Date	Life Expectancy Modifier	Life Expectancy Beyond Evaluation (years remaining)	Budget Year	Qty	Units	Prorate	Unit Cost	2019 Replacement Cost	Escalated Budget	
Component	Detail	Task	Task	Task	(0 is lowest)	(0 is lowest)	(0 is lowest)	(year)	%	(0 is lowest)						(As of Evaluation date)		
SITE COMPONENTS					3													
Site Components	Asphalt - Sealcoat		2017	2	2019			2019	38%	1	2020	4,900	sf		\$1.00	\$4,900	\$5,219	
Site Components	Asphalt Replacement		2017	15	2032			2019	0%	0	2032	4,900	sf		\$7.00	\$34,300	\$77,775	
Site Components	Concrete Walks		2017	40	2057		2	2019	0%	0	2057	2,300	sf		\$5.00	\$11,500	\$125,888	
Site Components	Concrete Patios		2017	20	2037		2	2019	0%	0	2037	1,925	sf		\$18.00	\$34,650	\$107,646	
Site Components	Landscaping		2017	50	2067		3	2019	0%	0	2067	169,884	sf		\$0.08	\$13,591	\$279,270	
Site Components	Parking Spaces/Lot (paint)		2017	2	2019		3	2019	38%	1	2020	18	each		\$55.00	\$990	\$1,054	
PLAY COMPONENTS																		
Play Component	Elevated Structures (2)		2017	15	2032		5	2019	0%	0	2032	2	each		\$25,000.00	\$50,000	\$113,374	See Accessibility Chart
Play Component	Ground Equipment		2017	15	2032		5	2019	0%	0	2032	7	each		\$2,500.00	\$17,500	\$39,681	See Accessibility Chart
Play Component	Mulch		2017	10	2027		5	2019	0%	0	2027	5,330	sf		\$5.00	\$26,650	\$44,106	
Play Component	Poured in Place		2017	15	2032		5	2019	0%	0	2032	1,370	sf		\$42.00	\$57,540	\$130,471	
Play Component	Edge Restraint		2017	40	2057		5	2019	0%	0	2057	360	lf		\$38.00	\$13,680	\$149,752	Plastic Edging
PARK AMENITIES																		
Park Amenities	Park Lighting		2017	20	2037			2019	0%	0	2037	2	each		\$2,500.00	\$5,000	\$15,533	
Park Amenities	Benches		2017	10	2027		5	2019	0%	0	2027	15	each		\$1,000.00	\$15,000	\$24,825	
Park Amenities	Trash/Recycling		2017	10	2027		5	2019	0%	0	2027	15	each		\$400.00	\$6,000	\$9,930	
Park Amenities	Bike Racks/Systems		2017	10	2027		5	2019	0%	0	2027	2	each		\$400.00	\$800	\$1,324	
Park Amenities	Drinking Fountains		2017	15	2032		5	2019	0%	0	2032	1	each		\$3,000.00	\$3,000	\$6,802	
Park Amenities	Pavilion (2 structures)		2017	25	2042		3	2019	0%	0	2042	1,065	sf		\$100.00	\$106,500	\$453,305	
Park Amenities	Picnic Grill		2017					2019	0%	0		2	each			\$0	\$0	
RECREATION COMPONENTS																		
Recreation Components	Basketball Courts		2017	20	2037		4	2019	0%	0	2037	1.0	each		\$115,000.00	\$115,000	\$357,265	
Recreation Components	Baseball Field		2017	50	2067		3	2019	0%	0	2067	2	each		\$35,000.00	\$35,000	\$719,199	
Recreation Components	Volley Ball Court		2017	20	2037		2	2019	0%	0	2037	1	each		\$25,000.00	\$25,000	\$77,666	
Recreation Components	Tennis Court (4)		2017	20	2037		4	2019	0%	0	2037	4	each		\$135,000.00	\$540,000	\$1,677,593	
					3.00	4.06	2.67									\$576,601	\$2,740,085	

NOTES

Evaluation of building conditions focused on the elements likely to be included in the budget for items expected to require replacement or renovation within the next 10 to 15 years. Equipment, materials, or assemblies that are nominal in cost are not included. This is therefore not a comprehensive list but does identify major expenses that are likely to be incurred in the foreseeable future.

Conditions change with time, and this evaluation, along with the funds allocated to cover the associated expenses should be reviewed and revised periodically as the department's needs evolve. Unanticipated expenses can develop for a number of reasons including accelerated use or changes in use patterns, accident, or deferred general maintenance. Such reviews should include updating baseline costs and dates for the components or assemblies identified in this study.

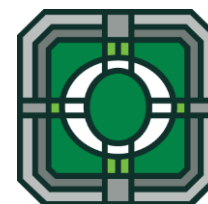
Costs are calculated at 2019 levels and escalated at the following presumed annual rate of inflation:

6.50% per annum

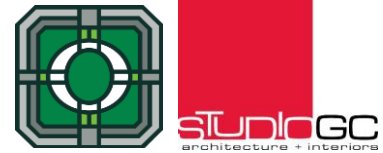
This report is broken up into different categories. The first three are organized by category with like expenses grouped together. The worksheets also covers Mechanical expenses, Electrical expenses, and Plumbing expenses. The last worksheet is organized by the computed year of expense (Budget Year).

Repair/replacement work items do not include A/E Design Fees in the cost.

Total Combined Facilities	
2020	\$6,273
2027	\$80,185
2032	\$368,104
2037	\$2,235,704
2042	\$453,305
2057	\$275,639
2067	\$998,469
Total:	\$4,417,678



NAME: VILLAGE SQUARE PARK
ADDRESS: 9030 Windsor Dr
PARK TYPE: Neighborhood
EVALUATION YEAR: 2019



PARK MAPS:



PARK DATA:

Year Renovated:	1998
Park Age:	21
Total Acreage:	12.5
Total Parking Spaces:	0

Amenities:

Playground Equipment - Gametime
 Baseball Field Tee Ball/ Youth
 Tennis Court One court
 Basketball Court 1/2 court
 Pavilion
 Fishing

SECURITY COMMENTS:

The park has good general security from the roadway. Some future considerations:

- Add secondary exit from tennis courts
- The eye level landscape should be trimmed to avoid blocking views from the street for security supervision.
- Security lighting should be considered if law enforcement has concerns.

Score **2.00**

ACCESSIBILITY COMMENTS

The accessibility review is conducted based on the 2010 ADA requirements. Please note specific accessibility evaluation was a not conducted. It is recommended that this is done provided there is a complaint. Given the age of this park compliance is not required but recommended.

- Mulch area is not accessible via ramp into mulch area
- District should review much refresh and verify depth requirements still are met.
- Baseball and basketball courts are not accessible via a paved path.

Score **2.00**

GENERAL CONDITION COMMENTS

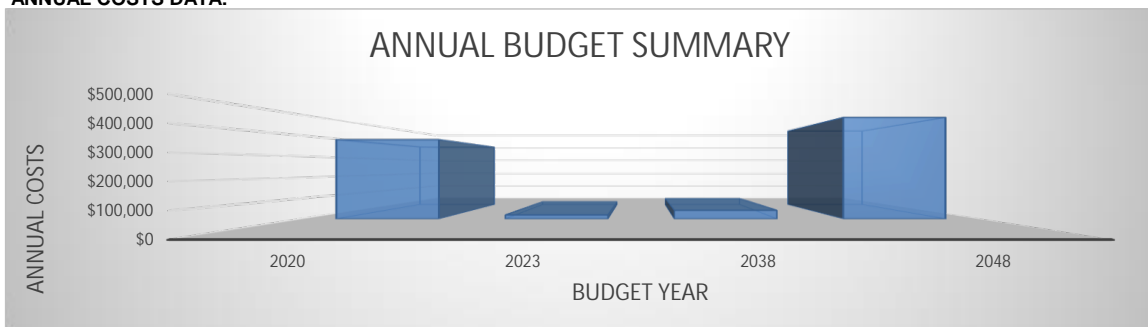
Given the age of the park it is in generally good condition. See notes below for a few items of note:

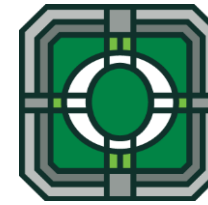
- The ground play elements are significantly deteriorated. The spring bouncer has pinch issues given the conditions.
- The plastic edging has been damaged or dislodged. This is not unexpected for this material.
- Landscape material has not been trimmed or maintained. It appears to be healthy as evident by the robust growth.

Score **2.25**

Score Average **2.08**

ANNUAL COSTS DATA:





COST BY BUDGET YEAR:

VILLAGE SQUARE PARK

Budget Year	Component	Detail	Values	
			Sum of 2019 Replacement Cost	Sum of Escalated Budget
2020	SITE COMPONENTS	Concrete Patios	\$18,000.00	\$19,170.00
		PARK AMENITIES	Benches	\$2,000.00
		Trash/Recycling	\$400.00	\$426.00
		Drinking Fountains	\$6,500.00	\$6,922.50
	Play Component	Elevated Structures (2)	\$25,000.00	\$26,625.00
		Ground Equipment	\$12,500.00	\$13,312.50
		Mulch	\$28,000.00	\$29,820.00
		Edge Restraint	\$15,656.00	\$16,673.64
	RECREATION COMPONENTS	Basketball Courts	\$115,000.00	\$122,475.00
		Tennis Court	\$135,000.00	\$143,775.00
2020 Total			\$358,056.00	\$381,329.64
2023	PARK AMENITIES	Pavilion	\$15,000.00	\$19,297.00
2023 Total			\$15,000.00	\$19,297.00
2038	SITE COMPONENTS	Concrete Walks	\$12,475.00	\$41,274.62
2038 Total			\$12,475.00	\$41,274.62
2048	SITE COMPONENTS	Landscaping	\$43,560.00	\$270,536.89
	RECREATION COMPONENTS	Baseball Field	\$35,000.00	\$217,373.54
2048 Total			\$78,560.00	\$487,910.43

VILLAGE SQUARE PARK		9030 Windsor Dr				General Conditions			Evaluated Condition			Estimated Cost Data - 2019						Comments	
Description/Life Expectancy		Task	Installed Date	Service Life	Anticipated Replacement Date	Security (1-5)	General (1-5)	Accessibility (1-5)	Evaluation Date	Life Expectancy Modifier	Life Expectancy Beyond Evaluation (years remaining)	Budget Year	Qty	Units	Prorate	Unit Cost	2019 Replacement Cost		Escalated Budget
Component	Detail		(year)	(years)	(year)	(0 is lowest)	(0 is lowest)	(0 is lowest)	(year)	%	(0 is lowest)						(As of Evaluation date)		
						3													
SITE COMPONENTS																			
Site Components	Concrete Walks		1998	40	2038		3	5	2019	0%	0	2038	2,495	sf		\$5.00	\$12,475	\$41,275	
Site Components	Concrete Patios		1998	20	2018		2	2	2019	10%	2	2020	1,000	sf		\$18.00	\$18,000	\$19,170	
Site Components	Landscaping		1998	50	2048				2019	0%	0	2048	544,500	sf		\$0.08	\$43,560	\$270,537	
PLAY COMPONENTS																			
Play Component	Elevated Structures (2)		1998	15	2013		3	4	2019	48%	7	2020	1	each		\$25,000.00	\$25,000	\$26,625	See Accessibility Chart
Play Component	Ground Equipment		1998	15	2013		2	3	2019	48%	7	2020	5	each		\$2,500.00	\$12,500	\$13,313	See Accessibility Chart
Play Component	Mulch		2010	10	2020		2	0	2019	0%	0	2020	5,600	sf		\$5.00	\$28,000	\$29,820	Owner Confirm Refresh Cycle
Play Component	Edge Restraint		1998	40	2038		1		2019	-45%	-18	2020	412	sf		\$38.00	\$15,656	\$16,674	Plastic Edging
PARK AMENITIES																			
Park Amenities	Benches		1998	10	2008		2	0	2019	120%	12	2020	2	each		\$1,000.00	\$2,000	\$2,130	
Park Amenities	Trash/Recycling		1998	10	2008		4		2019	120%	12	2020	1	each		\$400.00	\$400	\$426	
Park Amenities	Drinking Fountains		1998	15	2013				2019	48%	7	2020	1	each		\$6,500.00	\$6,500	\$6,923	
Park Amenities	Pavilion		1998	25	2023		2		2019	0%	0	2023	150	sf		\$100.00	\$15,000	\$19,297	
RECREATION COMPONENTS																			
Recreation Components	Basketball Courts		1998	20	2018		2	0	2019	10%	2	2020	1	each		\$115,000.00	\$115,000	\$122,475	
Recreation Components	Baseball Field		1998	50	2048		3	0	2019	0%	0	2048	1	each		\$35,000.00	\$35,000	\$217,374	
Recreation Components	Tennis Court		1998	20	2018	1	1	4	2019	10%	2	2020	1	each		\$135,000.00	\$135,000	\$143,775	
						2.00	2.25	2.00									\$464,091	\$929,812	

NOTES

Evaluation of building conditions focused on the elements likely to be included in the budget for items expected to require replacement or renovation within the next 10 to 15 years. Equipment, materials, or assemblies that are nominal in cost are not included. This is therefore not a comprehensive list but does identify major expenses that are likely to be incurred in the foreseeable future.

Conditions change with time, and this evaluation, along with the funds allocated to cover the associated expenses should be reviewed and revised periodically as the Department's needs evolve. Unanticipated expenses can develop for a number of reasons including accelerated use or changes in use patterns, accident, or deferred general maintenance. Such reviews should include updating baseline costs and dates for the components or assemblies identified in this study.

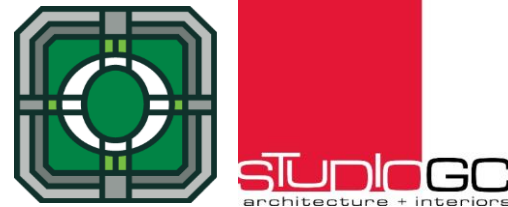
Costs are calculated at 2019 levels and escalated at the following presumed annual rate of inflation:

6.50% per annum

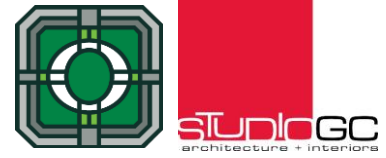
This report is broken up into different categories. The first three are organized by category with like expenses grouped together. The worksheets also covers Mechanical expenses, Electrical expenses, and Plumbing expenses. The last worksheet is organized by the computed year of expense (Budget Year).

Repair/replacement work items do not include A/E Design Fees in the cost.

Total Combined Facilities	
2020	\$381,330
2023	\$19,297
2038	\$41,275
2048	\$487,910
Total:	\$929,812



NAME: WEDGEWOOD COMMONS
ADDRESS: 14241 82nd Ave Orland Park, IL, USA
PARK TYPE: Mini
EVALUATION YEAR: 2019



PARK MAP:



PARK DATA:

Year Renovated:	2002
Park Age:	17
Total Acreage:	4
Total Parking Spaces:	0

Amenities:

Playground Equip: Landscape Struct.

SECURITY COMMENTS:

- Park security is as to be expected for this size facility. See a few specific areas of note and one concern:
- Great visibility from public ways
 - Security lighting should be considered if law enforcement has concerns.
 - Parking should be considered in future renovations

Score 3.00

ACCESSIBILITY COMMENTS

- Park was constructed prior to the 2010 regulations and is not required to be compliant.
- Play area does not have the required ramp.
 - Asphalt paths have deteriorated to the point they are no longer accessible
 - Play equipment should be evaluated for accessibility

Score 1.40

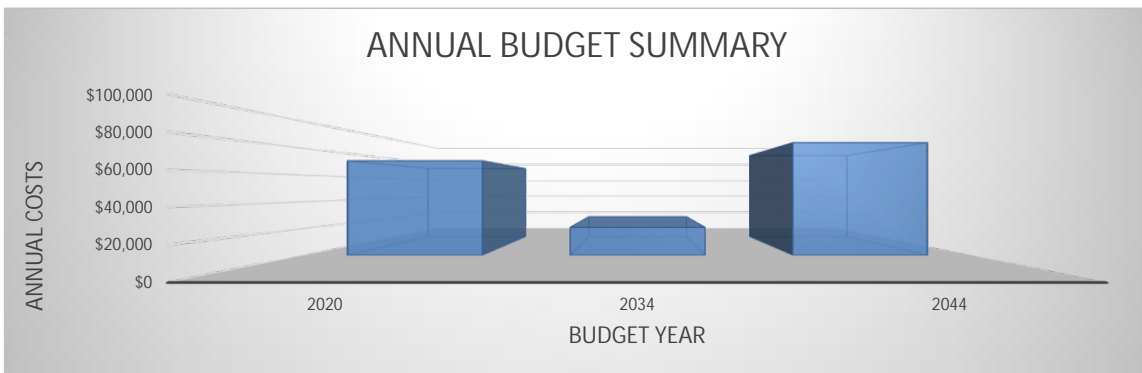
GENERAL CONDITION COMMENTS

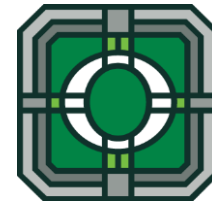
- Park is beyond it's typical useful life:
- Asphalt paths need replacement
 - Play equipment has finish deterioration.
 - Wood edge restraint needs to be replaced

Score 2.29

Score Average 2.23

ANNUAL COSTS GRAPH:





COST BY BUDGET YEAR:

WEDGEWOOD COMMONS

Budget Year	Component	Detail	Values	
			Sum of 2019 Replacement Cost	Sum of Escalated Budget
2020	PARK AMENITIES	Benches	\$2,000.00	\$2,130.00
		Trash/Recycling	\$400.00	\$426.00
	Play Component	Elevated Structures (2)	\$25,000.00	\$26,625.00
		Ground Equipment	\$7,500.00	\$7,987.50
		Mulch	\$21,500.00	\$22,897.50
		Edge Restraint	\$9,880.00	\$10,522.20
2020 Total			\$66,280.00	\$70,588.20
2034	SITE COMPONENTS	Walks	\$8,100.00	\$20,831.91
2034 Total			\$8,100.00	\$20,831.91
2044	SITE COMPONENTS	Landscaping	\$17,424.00	\$84,117.83
2044 Total			\$17,424.00	\$84,117.83
Grand Total			\$91,804.00	\$175,537.94

WEDGEWOOD COMMONS		14241 82nd Ave Orland Park, IL, USA				General Conditions			Evaluated Condition			Estimated Cost Data - 2019						Comments	
Description/Life Expectancy		Task	Installed Date	Service Life	Anticipated Replacement Date	Security (1-5)	General (1-5)	Accessibility (1-5)	Evaluation Date	Life Expectancy Modifier	Life Expectancy Beyond Evaluation (years remaining)	Budget Year	Qty	Units	Prorate	Unit Cost	2019 Replacement Cost		Escalated Budget
Component	Detail		(year)	(years)	(year)	(0 is lowest)	(0 is lowest)	(0 is lowest)	(year)	%	(0 is lowest)						(As of Evaluation date)		
SITE COMPONENTS						3													
Site Components	Walks		1994	40	2034		2	1	2019	0%	0	2034	1,620	sf		\$5.00	\$8,100	\$20,832	
Site Components	Landscaping		1994	50	2044		3		2019	0%	0	2044	174,240	sf		\$0.10	\$17,424	\$84,118	
PLAY COMPONENTS																			
Play Component	Elevated Structures (2)		1994	15	2009		2	2	2019	75%	11	2020	1	each		\$25,000.00	\$25,000	\$26,625	See Accessibility Chart
Play Component	Ground Equipment		1994	15	2009		2	2	2019	75%	11	2020	3	each		\$2,500.00	\$7,500	\$7,988	See Accessibility Chart
Play Component	Mulch		2010	10	2020		3	1	2019	0%	0	2020	4,300	sf		\$5.00	\$21,500	\$22,898	
Play Component	Edge Restraint		1994	40	2034		1		2019	-35%	-14	2020	260	lf		\$38.00	\$9,880	\$10,522	Plastic Edging
PARK AMENITIES																			
Park Amenities	Benches		1994	10	2004		3	1	2019	160%	16	2020	2	each		\$1,000.00	\$2,000	\$2,130	
Park Amenities	Trash/Recycling		1994	10	2004				2019	160%	16	2020	1	each		\$400.00	\$400	\$426	
RECREATION COMPONENTS																			
						3.00	2.29	1.40											
																	\$91,804	\$175,538	

NOTES

Evaluation of building conditions focused on the elements likely to be included in the budget for items expected to require replacement or renovation within the next 10 to 15 years. Equipment, materials, or assemblies that are nominal in cost are not included. This is therefore not a comprehensive list but does identify major expenses that are likely to be incurred in the foreseeable future.

Conditions change with time, and this evaluation, along with the funds allocated to cover the associated expenses should be reviewed and revised periodically as the Department's needs evolve. Unanticipated expenses can develop for a number of reasons including accelerated use or changes in use patterns, accident, or deferred general maintenance. Such reviews should include updating baseline costs and dates for the components or assemblies identified in this study.

Costs are calculated at 2019 levels and escalated at the following presumed annual rate of inflation:

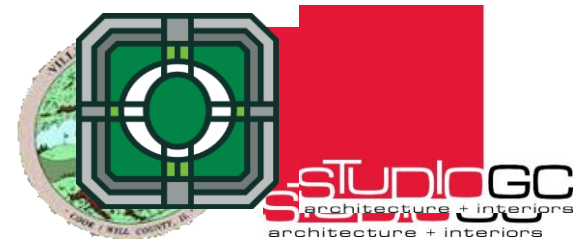
6.50% per annum

This report is broken up into different categories. The first three are organized by category with like expenses grouped together. The worksheets also covers Mechanical expenses, Electrical expenses, and Plumbing expenses. The last worksheet is organized by the computed year of expense (Budget Year).

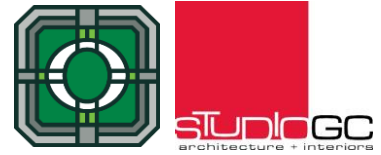
Repair/replacement work items do not include A/E Design Fees in the cost.

Total Combined Facilities

2020	\$70,588
2034	\$20,832
2044	\$84,118
Total:	\$175,538



NAME: WEDGEWOOD ESTATES PARK
ADDRESS: [8200 Eynsford Dr. Orland Park, IL](#)
PARK TYPE: Neighborhood
EVALUATION YEAR: 2019



PARK MAP:



PARK DATA:

Year Renovated:	1994
Park Age:	25
Total Acreage:	3
Total Parking Spaces:	7 + 1HC

Amenities:

Playground Equip:	Landscape Struct.
Tennis Courts	2
Basketball Court	Half Court
Pickleball Courts	
Bike/Walking Path	

SECURITY COMMENTS:

Park security is as to be expected for this size facility. See a few specific areas of note and one concern:

- Great visibility from public ways
- Security lighting should be considered if law enforcement has concerns.

Score **3.00**

ACCESSIBILITY COMMENTS

Park was constructed prior to 2010 regulations and as such is not required to be compliant. A few items are of note:

- Play equipment should be evaluated for compliance to current regulations.
- Play area is not accessible due to lack of ramps.
- Basketball court is not on accessible route

Score **1.83**

GENERAL CONDITION COMMENTS

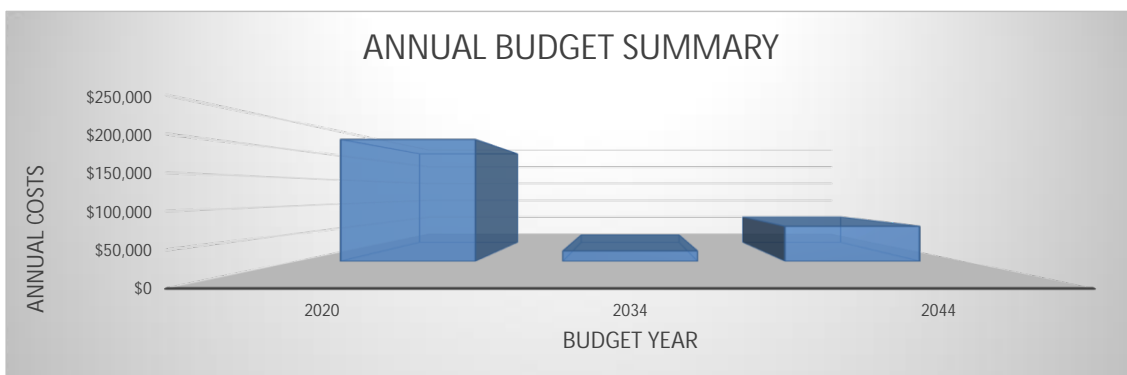
Park is expected condition given the age of the park. There are a few items of note:

- Basketball court has lost all surface finishes and appears to be holding water.
- Tennis court has asphalt cracks and heaving at fence line.
- Playground equipment has finish deterioration.
- Asphalt paths are significantly deteriorated and in need of replacement.
- Replace wood edge restraint, significantly deteriorated

Score **2.25**

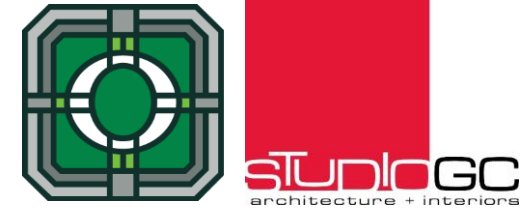
Score Average **2.36**

ANNUAL COSTS GRAPH:



COST BY BUDGET YEAR:

WEDGEWOOD ESTATES PARK



Budget Year	Component	Detail	Values		
			Sum of 2019 Replacement Cost	Sum of Escalated Budget	
2020	SITE COMPONENTS	Asphalt - Sealcoat	\$2,000.00	\$2,130.00	
		Asphalt Replacement	\$14,000.00	\$14,910.00	
		Parking Spaces/Lot (7+1HC)	\$500.00	\$532.50	
	PARK AMENITIES	Benches	\$2,000.00	\$2,130.00	
		Trash/Recycling	\$400.00	\$426.00	
	Play Component	Elevated Structures (2)	\$75,000.00	\$79,875.00	
		Ground Equipment	\$10,000.00	\$10,650.00	
		Mulch	\$27,500.00	\$29,287.50	
		Edge Restraint		\$17,214.00	\$18,332.91
	RECREATION COMPONENTS	Basketball Courts	\$57,500.00	\$61,237.50	
Tennis Court		\$24.00	\$25.56		
2020 Total			\$206,138.00	\$219,536.97	
2034	SITE COMPONENTS	Concrete Walks	\$7,250.00	\$18,645.85	
2034 Total			\$7,250.00	\$18,645.85	
2044	SITE COMPONENTS	Landscaping	\$13,068.00	\$63,088.37	
2044 Total			\$13,068.00	\$63,088.37	
Grand Total			\$226,456.00	\$301,271.19	

WEDGEWOOD ESTATES PARK 8200 Eynsford Dr, Orland Park, IL																			
Description/Life Expectancy						General Conditions			Evaluated Condition			Estimated Cost Data - 2019							
Component	Detail	Task	Installed Date	Service Life	Anticipated Replacement Date	Security (1-5)	General (1-5)	Accessibility (1-5)	Evaluation Date	Life Expectancy Modifier	Life Expectancy Beyond Evaluation (years remaining)	Budget Year	Qty	Units	Prorate	Unit Cost	2019 Replacement Cost	Escalated Budget	Comments
			(year)	(years)	(year)	(0 is lowest)	(0 is lowest)	(0 is lowest)	(year)	%	(0 is lowest)						(As of Evaluation date)		
SITE COMPONENTS						3													
Site Components	Asphalt - Sealcoat		2017	2	2019		2		2019	30%	1	2020	2,000	sf		\$1.00	\$2,000	\$2,130	
Site Components	Asphalt Replacement		1994	15	2009		2		2019	72%	11	2020	2,000	sf		\$7.00	\$14,000	\$14,910	
Site Components	Concrete Walks		1994	40	2034		3	1	2019	0%	0	2034	1,450	sf		\$5.00	\$7,250	\$18,646	
Site Components	Landscaping		1994	50	2044		3		2019	0%	0	2044	130,680	sf		\$0.10	\$13,068	\$63,088	
Site Components	Parking Spaces/Lot (7+1HC)		2017	2	2019		2		2019	30%	1	2020	26	each		\$0.25	\$500	\$533	2 Handicapped
PLAY COMPONENTS																			
Play Component	Elevated Structures (2)		1994	15	2009		2	2	2019	72%	11	2020	3	each		\$25,000.00	\$75,000	\$79,875	See Accessibility Chart
Play Component	Ground Equipment		1994	15	2009		2		2019	72%	11	2020	4	each		\$2,500.00	\$10,000	\$10,650	See Accessibility Chart
Play Component	Mulch		2010	10	2020		3	1	2019	0%	0	2020	5,500	sf		\$5.00	\$27,500	\$29,288	
Play Component	Edge Restraint		1994	40	2034		1		2019	-35%	-14	2020	453	sf		\$38.00	\$17,214	\$18,333	Plastic Edging
PARK AMENITIES																			
Park Amenities	Benches		1994	10	2004		2	3	2019	160%	16	2020	2	each		\$1,000.00	\$2,000	\$2,130	
Park Amenities	Trash/Recycling		1994	10	2004				2019	160%	16	2020	1	each		\$400.00	\$400	\$426	
RECREATION COMPONENTS																			
Recreation Components	Basketball Courts		1994	20	2014		2	1	2019	30%	6	2020	0.5	each		\$115,000.00	\$57,500	\$61,238	
Recreation Components	Tennis Court		1994	20	2014		3	3	2019	30%	6	2020	2	sf		\$12.00	\$24	\$26	
								0											
						3.00	2.25	1.83										\$226,456	\$301,271

NOTES

Evaluation of building conditions focused on the elements likely to be included in the budget for items expected to require replacement or renovation within the next 10 to 15 years. Equipment, materials, or assemblies that are nominal in cost are not included. This is therefore not a comprehensive list but does identify major expenses that are likely to be incurred in the foreseeable future.

Conditions change with time, and this evaluation, along with the funds allocated to cover the associated expenses should be reviewed and revised periodically as the department's needs evolve. Unanticipated expenses can develop for a number of reasons including accelerated use or changes in use patterns, accident, or deferred general maintenance. Such reviews should include updating baseline costs and dates for the components or assemblies identified in this study.

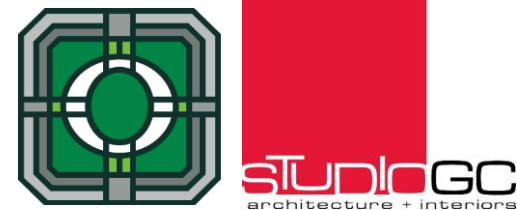
Costs are calculated at 2019 levels and escalated at the following presumed annual rate of inflation:

6.50% per annum

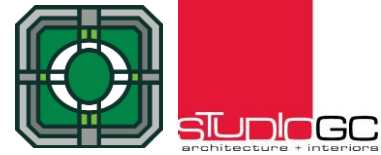
This report is broken up into different categories. The first three are organized by category with like expenses grouped together. The worksheets also covers Mechanical expenses, Electrical expenses, and Plumbing expenses. The last worksheet is organized by the computed year of expense (Budget Year).

Repair/replacement work items do not include A/E Design Fees in the cost.

Total Combined Facilities	
2020	\$219,537
2034	\$18,646
2044	\$63,088
Total:	\$301,271



NAME: WLODARSKI PARK
ADDRESS: 16651 Robinhood Drive, Orland Park
PARK TYPE: Neighborhood
EVALUATION YEAR: 2019



PARK MAPS:



PARK DATA:

Year Renovated:	2002
Park Age:	17
Total Acreage:	1.4
Total Parking Spaces:	

Amenities:

Playground Equip: Miracle

SECURITY COMMENTS:

Score **3.00**

- Park security is as to be expected for this size facility. See a few specific areas of note and one concern:
- Great visibility from public ways
 - Security lighting should be considered if law enforcement has concerns.

ACCESSIBILITY COMMENTS

Score **2.43**

- Park was built prior to the 2010 regulations and as such is not required to be compliant. There are a few items of note:
- Fiber play area appears to be overly compacted.
 - Asphalt paths are beginning to not be considered accessible.
 - Baseball field is not on accessible path

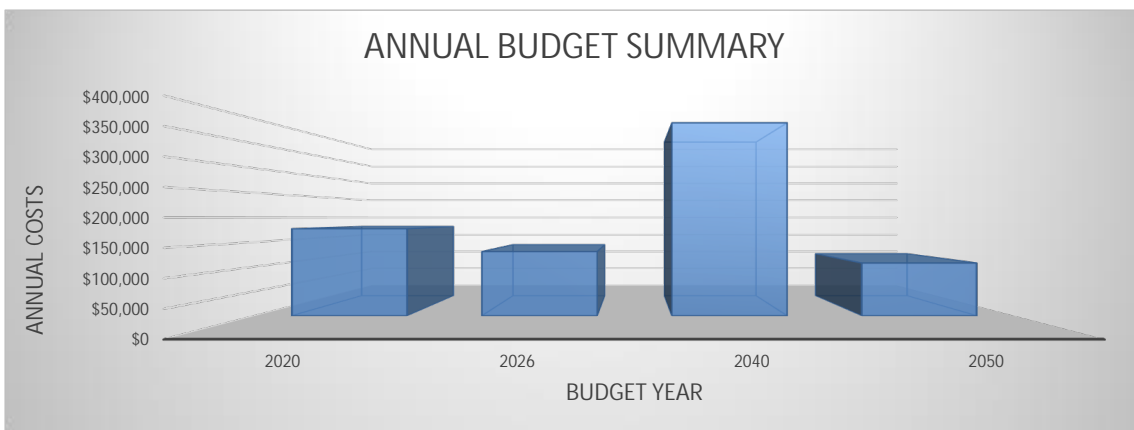
GENERAL CONDITION COMMENTS

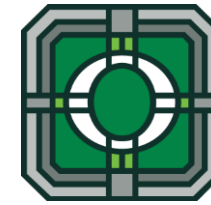
Score **2.42**

- Park has aged well considering the age. There are a few items of note:
- Play equipment has finish deterioration
 - Play sand area likely has bee infestation and is reducing the overall condition of the park.
 - Fibar is washing out indicating drainage and grading issues.

Score Average **2.62**

ANNUAL COSTS GRAPH





COST BY BUDGET YEAR:

WLODARSKI PARK

Budget Year	Component	Detail	Values	
			Sum of 2019 Replacement Cost	Sum of Escalated Budget
2020	SITE COMPONENTS	Concrete Patios	\$18,000.00	\$19,170.00
		Asphalt - Sealcoat	\$12,200.00	\$12,993.00
		Parking Spaces/Lot (7+1HC)	\$2,600.00	\$2,769.00
	PARK AMENITIES	Benches	\$2,000.00	\$2,130.00
		Trash/Recycling	\$400.00	\$426.00
	Play Component	Elevated Structures (2)	\$50,000.00	\$53,250.00
		Ground Equipment	\$25,000.00	\$26,625.00
		Mulch	\$54,000.00	\$57,510.00
		Play Sand area	\$2,000.00	\$2,130.00
2020 Total			\$166,200.00	\$177,003.00
2026	SITE COMPONENTS	Asphalt Replacement	\$84,000.00	\$130,534.87
2026 Total			\$84,000.00	\$130,534.87
2040	SITE COMPONENTS	Concrete Walks	\$75,000.00	\$281,451.15
	Play Component	Edge Restraint	\$29,526.00	\$110,801.69
2040 Total			\$104,526.00	\$392,252.84
2050	SITE COMPONENTS	Landscaping	\$15,246.00	\$107,397.40
2050 Total			\$15,246.00	\$107,397.40
Grand Total			\$369,972.00	\$807,188.11

WLODARSKI PARK		16651 Robinhood Drive, Orland Park				General Conditions			Evaluated Condition			Estimated Cost Data - 2019						Comments	
Description/Life Expectancy		Task	Installed Date	Service Life	Anticipated Replacement Date	Security (1-5)	General (1-5)	Accessibility (1-5)	Evaluation Date	Life Expectancy Modifier	Life Expectancy Beyond Evaluation (years remaining)	Budget Year	Qty	Units	Prorate	Unit Cost	2019 Replacement Cost		Escalated Budget
Component	Detail		(year)	(years)	(year)	(0 is lowest)	(0 is lowest)	(0 is lowest)	(year)	%	(0 is lowest)						(As of Evaluation date)		
						3													
SITE COMPONENTS																			
Site Components	Asphalt - Sealcoat		2017	2	2019		2		2019	30%	1	2020	12,200	sf		\$1.00	\$12,200	\$12,993	2 Handicapped
Site Components	Asphalt Replacement		2000	15	2015		2		2019	72%	11	2026	12,000	sf		\$7.00	\$84,000	\$130,535	
Site Components	Parking Spaces/Lot (7+1HC)		2017	2	2019		2		2019	30%	1	2020	26	each		\$100.00	\$2,600	\$2,769	
Site Components	Concrete Walks		2000	40	2040		3	3	2019	0%	0	2040	15,000	sf		\$5.00	\$75,000	\$281,451	
Site Components	Concrete Patios		2000	20	2020		3	3	2019	0%	0	2020	1,000	sf		\$18.00	\$18,000	\$19,170	
Site Components	Landscaping		2000	50	2050		3		2019	0%	0	2050	60,984	sf		\$0.25	\$15,246	\$107,397	
PLAY COMPONENTS																			
Play Component	Elevated Structures (2)		2000	15	2015		2	2	2019	35%	5	2020	2	each		\$25,000.00	\$50,000	\$53,250	
Play Component	Ground Equipment		2000	15	2015		2	2	2019	35%	5	2020	10	each		\$2,500.00	\$25,000	\$26,625	
Play Component	Mulch		2010	10	2020		2	3	2019	0%	0	2020	10,800	sf		\$5.00	\$54,000	\$57,510	
Play Component	Play Sand area		2010	10	2020		1	1	2019	0%	0	2020	400	sf		\$5.00	\$2,000	\$2,130	
Play Component	Edge Restraint		2000	40	2040		4		2019	0%	0	2040	777	sf		\$38.00	\$29,526	\$110,802	
PARK AMENITIES																			
Park Amenities	Benches		2000	10	2010		3	3	2019	100%	10	2020	2	each		\$1,000.00	\$2,000	\$2,130	
Park Amenities	Trash/Recycling		2000	10	2010				2019	100%	10	2020	1	each		\$400.00	\$400	\$426	
RECREATION COMPONENTS																			
						3.00	2.42	2.43									\$369,972	\$807,188	

NOTES

Evaluation of building conditions focused on the elements likely to be included in the budget for items expected to require replacement or renovation within the next 10 to 15 years. Equipment, materials, or assemblies that are nominal in cost are not included. This is therefore not a comprehensive list but does identify major expenses that are likely to be incurred in the foreseeable future.

Conditions change with time, and this evaluation, along with the funds allocated to cover the associated expenses should be reviewed and revised periodically as the Department's needs evolve. Unanticipated expenses can develop for a number of reasons including accelerated use or changes in use patterns, accident, or deferred general maintenance. Such reviews should include updating baseline costs and dates for the components or assemblies identified in this study.

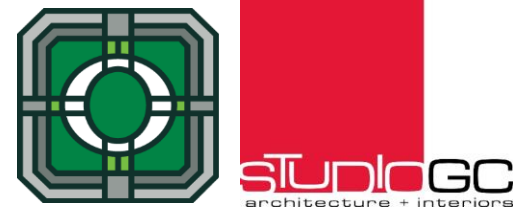
Costs are calculated at 2019 levels and escalated at the following presumed annual rate of inflation:

6.50% per annum

This report is broken up into different categories. The first three are organized by category with like expenses grouped together. The worksheets also covers Mechanical expenses, Electrical expenses, and Plumbing expenses. The last worksheet is organized by the computed year of expense (Budget Year).

Repair/replacement work items do not include A/E Design Fees in the cost.

Total Combined Facilities	
2020	\$177,003
2026	\$130,535
2040	\$392,253
2050	\$107,397
Total:	\$807,188



For more location information
please visit www.strand.com

Office Locations

Brenham, Texas | 979.836.7937

Cincinnati, Ohio | 513.861.5600

Columbus, Indiana | 812.372.9911

Columbus, Ohio | 614.835.0460

Joliet, Illinois | 815.744.4200

Lexington, Kentucky | 859.225.8500

Louisville, Kentucky | 502.583.7020

Madison, Wisconsin* | 608.251.4843

Milwaukee, Wisconsin | 414.271.0771

Phoenix, Arizona | 602.437.3733

*Corporate Headquarters

